

Trio liet
Kuilvoerdoseerwagen
Multifeed

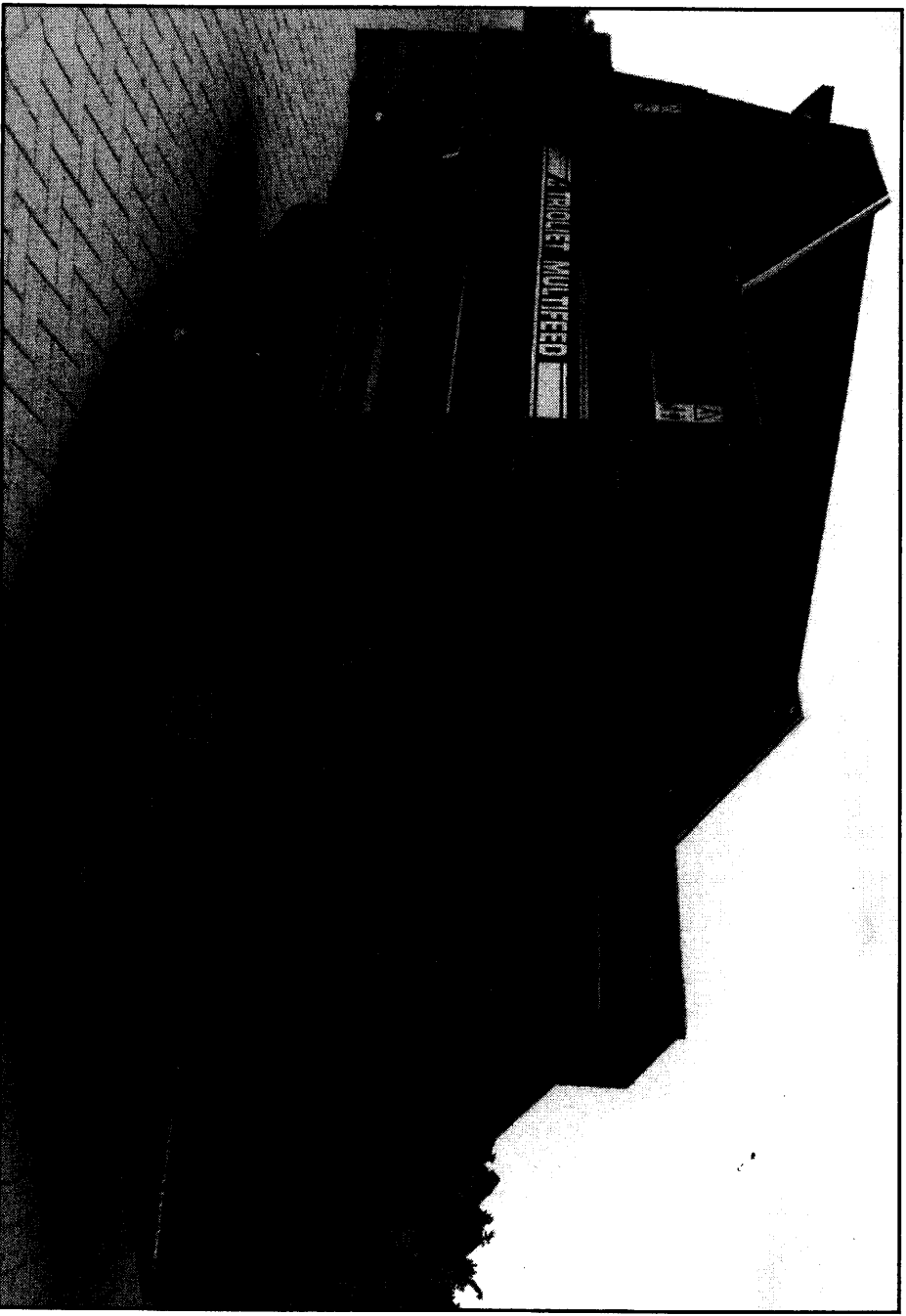

Onderdelenlijst / Ersatzteilliste / Sparepartlist

Bestelnummer / Bestellnummer 92070/3

Geldig vanaf productieserie nr. / Gültig ab Prod. Series No.: 02

INHOUDSOPGAVE

Afb. 1	Stickers
2A	Laadklep 01 ↔ 03
2B	Laadklep ↳ 04
3	Bodemketting
4A	Dwarsband 01 ↔ 03
4B	Dwarsband ↳ 04
5A	Wielstel, enkel wiel
5B	Wielstel, dubbel wiel
6A	Trekboom 01 ↔ 03
6B	Trekboom ↳ 04
7	Walsaandrijving
8A	Doseerwals 01 ↔ 03
8B	Doseerwals ↳ 04
9	Terugkrabrotor
10A	Doseerrol, serie 02
10B	Doseerrol, serie 03
10C	Doseerrol, vanaf serie 04
11A	Hydr. bodemkettingaandrijving 01 ↔ 03
12	Laadklepcilinder
13A	3-Handel stroomregelventiel serie 01↔04
13B	2-Handel en stroomregelventiel vanaf serie 05
14	Aftakas
15A	Hydraulisch schema serie 01↔04
15B	Hydraulisch schema serie vanaf serie 05

INHALTVERZEICHNIS

Abb. 1	Aufkleber
2A	Ladeklappen 01 ↔ 03
2B	Ladeklappen ↳ 04
3	Bodenkette
4A	Querförderband 01 ↔ 03
4B	Querförderband ↳ 04
5A	Radachse, Standard
5B	Radachse, Doppelräder
6A	Deichsel 01 ↔ 03
6B	Deichsel ↳ 04
7	Antrieb der Walze
8A	Dosierwalze 01 ↔ 03
8B	Dosierwalze ↳ 04
9	Gegenrotor
10A	Stabwalze, Serie 02
10B	Stabwalze, Serie 03
10C	Stabwalze ↳ 04
11	Hydraulische Bodenkettenantrieb 01 ↔ 03
12	Ladeklappenzyliner
13A	3-Hebel Stromregelventil 01↔04
13B	2-Hebel und Stromregelventil ↳ 05
14	Zapfwelle
15A	Hydraulischer Schaltplan 01↔04
15B	Hydraulischer Schaltplan ↳ 05

CONTENTS

Fig. 1	Decals
2A	Loading platform 01 ↔ 03
2B	Loading platform ↳ 04
3	Bottom chain
4A	Side conveyor 01 ↔ 03
4B	Side conveyor ↳ 04
5A	Wheelset, single wheel
5B	Wheelset, twin wheels
6A	Drawbar 01 ↔ 03
6B	Drawbar ↳ 04
7	Gearbox and drive system
8A	Roller 01 ↔ 03
8B	Roller ↳ 04
9	Pick-up rotor
10A	Open roller, serie 02
10B	Open roller, serie 03
10C	Open roller, serie 04
11	Hydraulic drive system 01 ↔ 03
12	Cylinder loading platform
13A	3-Handle-flow control-valve 01↔04
13B	2-Handle-flow and control-valve ↳ 05
14	PTO-shaft
15A	Hydraulic scheme 01↔04
15B	Hydraulic scheme ↳ 05

92070/3

Afbeelding 1 : Stickers

Abbildung 1 : Aufkleber

Picture 1 : Decals

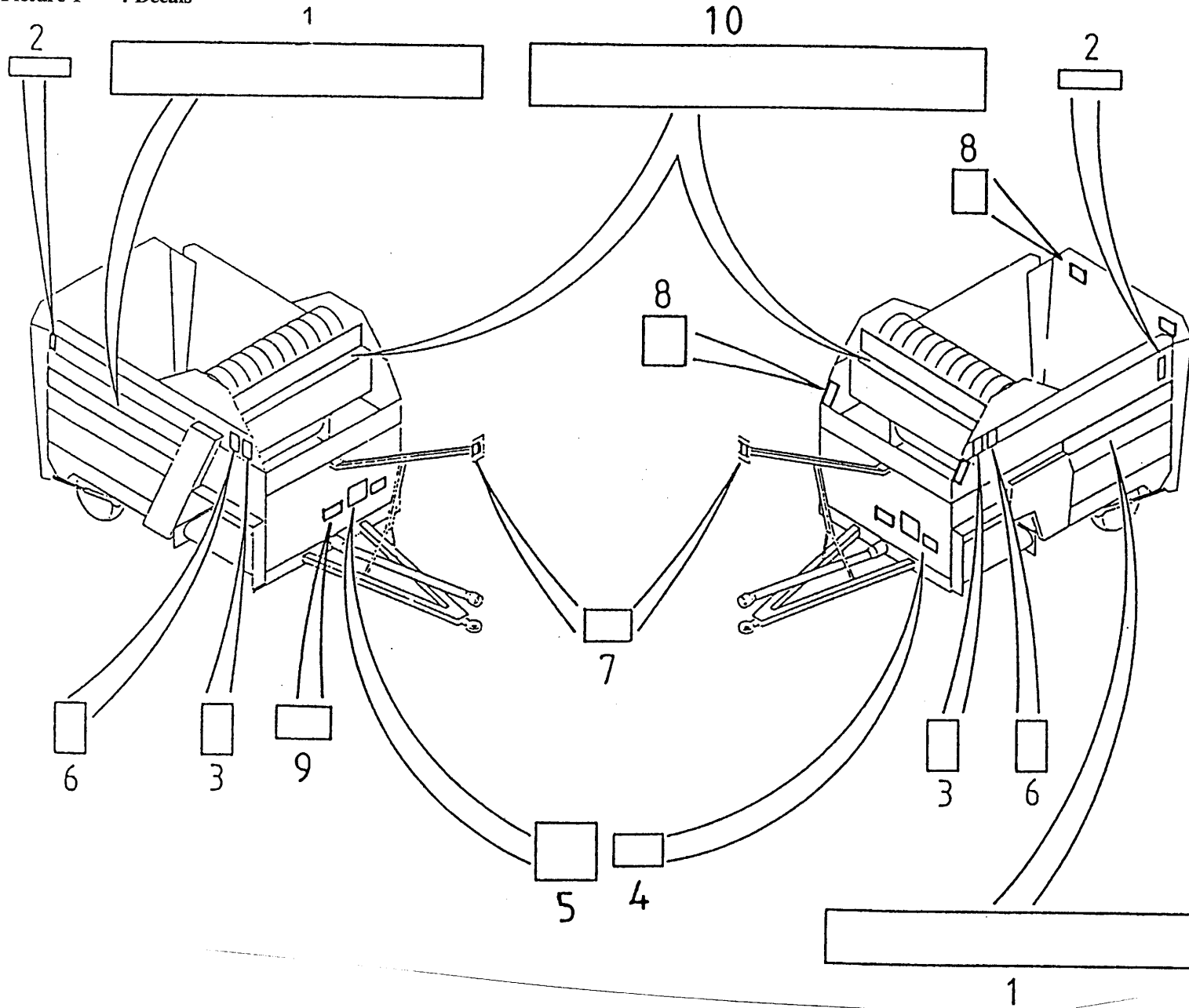

bestelnummer
ordernummer
num.à commander
Bestellnummer

1	91176	2
2	91173	2
3	91162	2
4	91159	1
5	91160	1
6	91213	2
7	91097	1
8	91183	4
9	91193	1
10A	91194	1
10B	91176	1

serie 01 + 02
↳ 03

92070/3

Afbeelding 2A : Laadklep 01 ↔ 03

Abbildung 2A : Ladeklappe 01 ↔ 03

Picture 2A : Loading Platform 01 ↔ 03

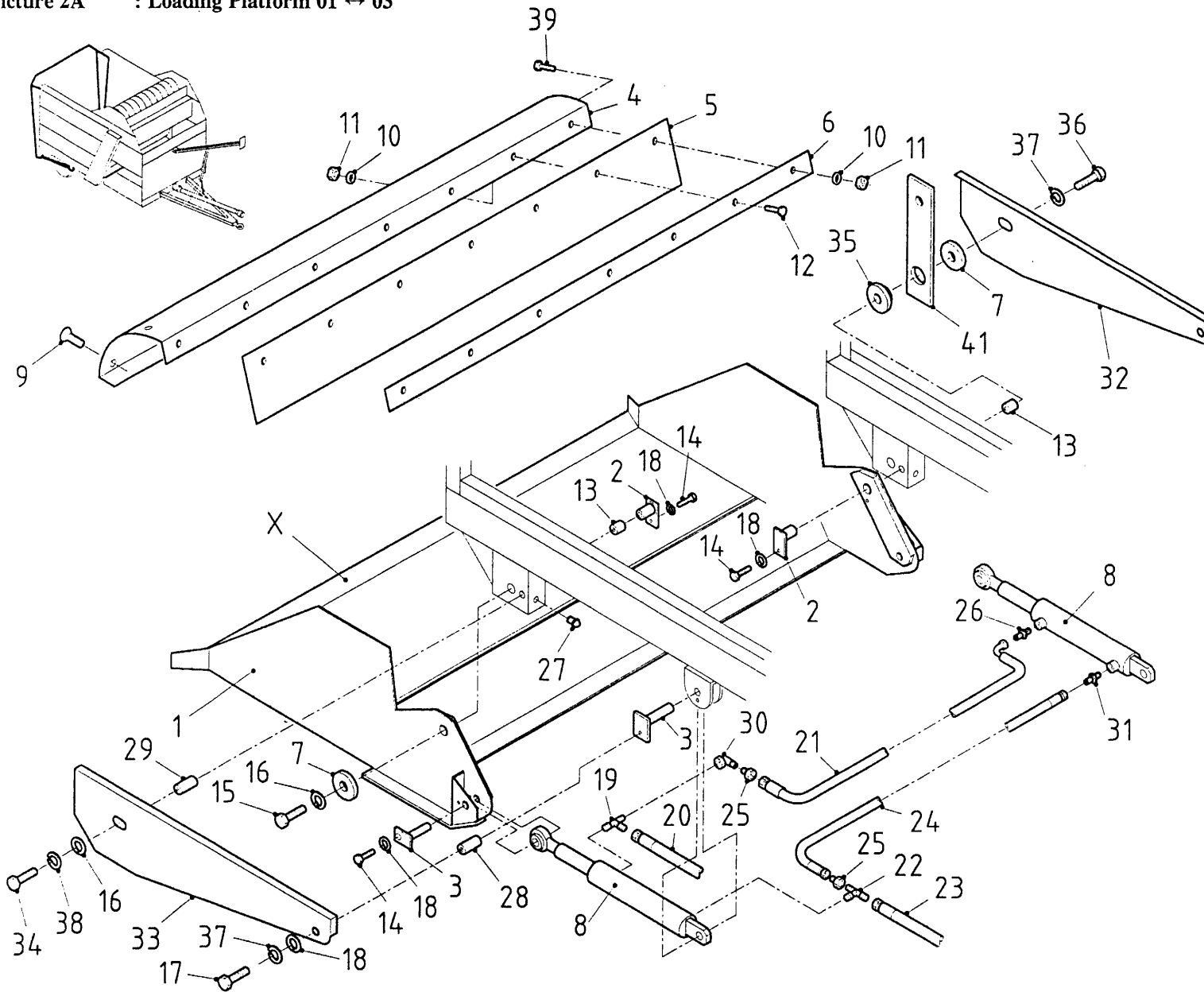

bestelnummer
ordernummer
num.à commander
Bestellnummer

1	11506	1	
2	11370	2	
3	11063	4	
4	23337	1	
5	60188	1	
6	22556	1	
7	22445	2	
8	50088	2	
9	84171	6	M 10 x 25
10	85108	5	M 8
11	86208	5	M 8
12	80831	5	M 8 x 30
13	85912	2	
14	80816	4	M 8 x 16
15	81220	1	M 12 x 20
16	85012	2	M 12
17	80856	2	M 8 x 55
18	85008	6	M 8
19	X50310	1	
20	W50765	1	½" 4300RR
21	W50826	1	⅜" 2400RH
22	X50350	1	
23	W50764	1	½" 3900RR
24	W50716	1	⅜" 2000RHZ
25	X50154	2	
26	X50113	1	
27	89510	2	M 6
28	23061	2	L = 45
29	23062	2	L = 21
30	X50143	1	
31	X50141	1	
32	23060	1	
33	23059	1	
34	81265	2	M 12 x 65
36	81241	1	M 12 x 40
37	85108	2	M 8
38	85112	2	M 12
39	80846	2	M 8 x 45
41	23898	1	

92070/3

Afbeelding 2B : Laadklep ↳ 04

Abbildung 2B : Ladeklappe ↳ 04

Picture 2B : Loading Platform ↳ 04

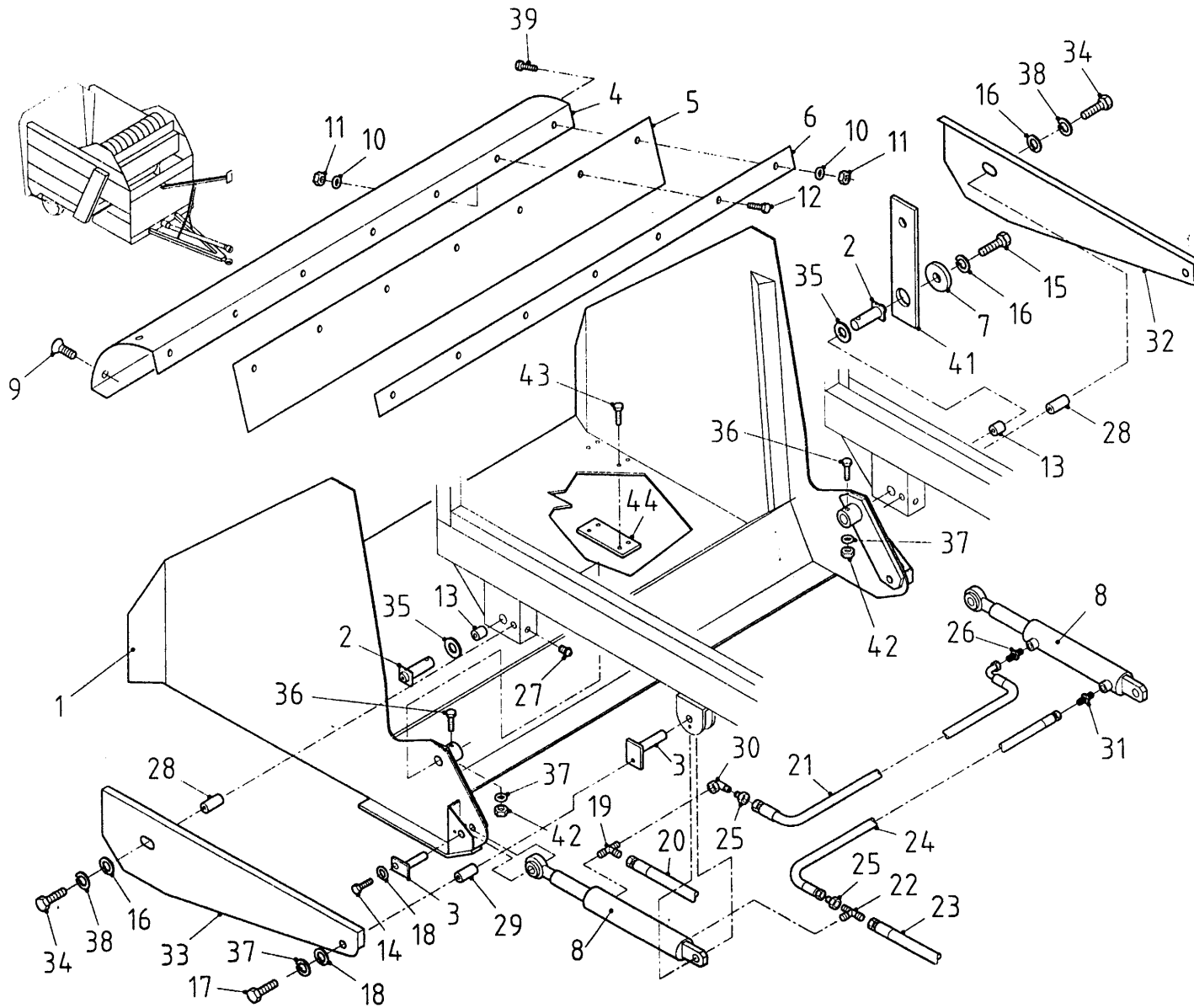

bestelnummer
ordernummer
num.à commander
Bestellnummer

1	11506	1
2	11713	2
3	11063	4
4	23337	1
5	60188	1
6	22556	1
7	22445	2
8	50088	2
9	84171	6 M10 x 25
10	85108	11 M8
11	86208	11 M8
12	80831	11 M8 x 30
13	85912	2
14	80816	4 M8 x 16
15	81220	1 M12 x 20
16	85012	2 M12
17	80856	2 M8 x 55
18	85008	6 M8
19	X50310	1
20	W50765	1 ½" 4300 RR
21	W50826	1 ⅜" 2400 RH
22	X50350	1
23	W50764	1 ½" 3900 RR
24	W50716	1 ⅜" 2000 RH
25	X50154	2
26	X50113	1
27	89510	2 M6
28	23061	2 L = 45
29	23062	2 L = 31
30	X50143	1
31	X50141	1
32	23060	1
33	23059	1
34	81265	2 M12 x 65
35	85332	2
36	81075	2 M10 x 75
37	85110	2 M10
38	85112	2 M12
39	80846	2 M8 x 45
41	23898	1
42	86210	2 M10
43	84926	8 M10 x 19
44	24460	2

92070/3

Afbeelding 3 : Bodemketting

Abbildung 3 : Bodenkette

Picture 3 : Bottom chain

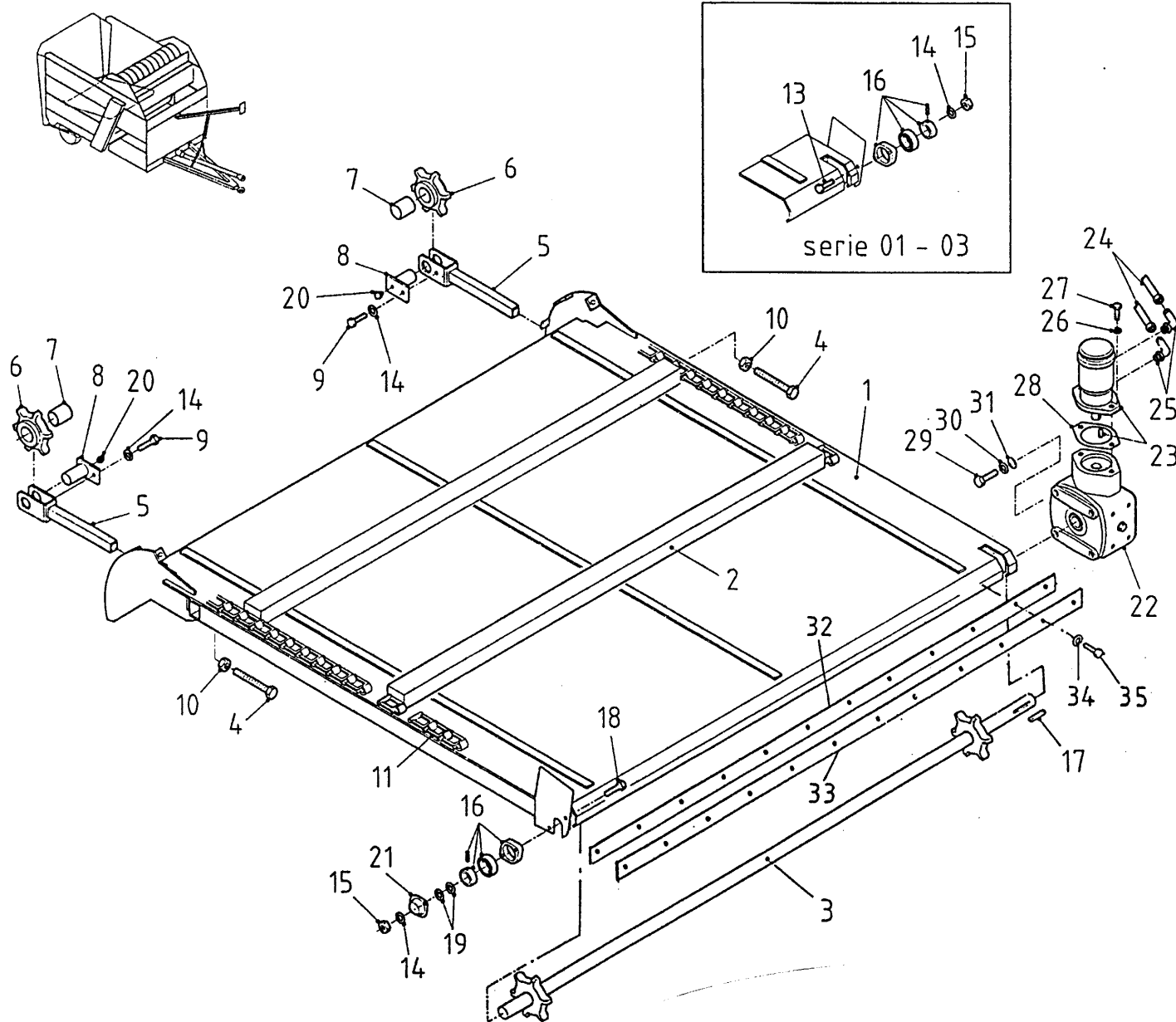

bestelnummer
 ordernummer
 num.à commander
 Bestellnummer

1	11028	1	
2	11051	9	
3	11049	1	
4	11034	2	M20x150
5A	11367	1	→ I 03
5B	11718	1	↳ 04
6	39072	2	
7	85909	2	
8	11369	2	
9	81020	2	M10 x 20
10	86120	2	M20
11	39010	114	
13	81045	2	M10 x 45
14	85010	4	M10
15	86210	2	M10
16	70059	1	
17	88331	1	
18	81055	2	M10 x 55
19	85123	2	M10
20	89510	2	M6
21	23303	1	
22	90297	1	
23A	50046	1	Danfos
23B	50073	1	White
24	W50764	2	½" 3900 RR
25	X50123	2	
26	85012	2	M12
27	81236	2	M12 x 55
28	60231	1	
29	81021	3	M10 x 20
30	85010	3	M10
31	85110	3	M10
32	60287	1	
33	25041	1	
34	85106	12	M6
35	80621	12	M6 x 20

92070/3

Afbeelding 4A : Dwarsband 01 ↔ 03

Abbildung 4A : Querförderband 01 ↔ 03

Picture 4A : Side conveyor 01 ↔ 03

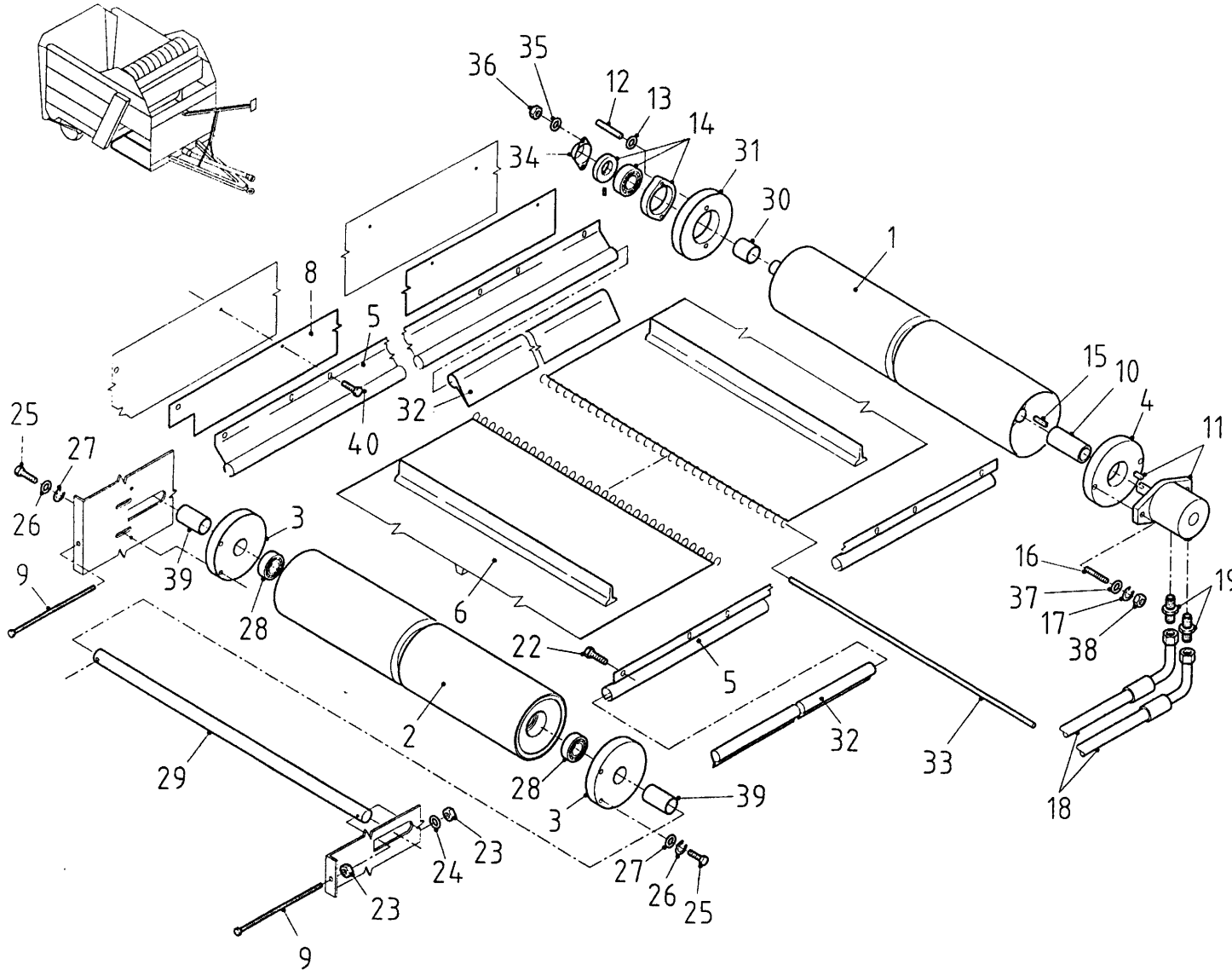

bestelnummer
ordernummer
num.à commander
Bestellnummer

1	11037	1	
2	11136	1	
3	60224	2	
4	31181	1	
5	90274	2	
6	60173	1	
8	60229	1	
9	81017	2	M10 x 150
10	30899	1	
11A	50077	1	Danfoss
11B	51084	1	White
12	84172	2	M8 x 70
13	85008	2	M8
14	70084	1	
15	88330	1	
16	84108	2	M12 x 60
17	85012	2	M12
18	W50768	2	½" 3000 RH
19	X50117	2	
22	84712	11	M6,3 x 16
23	86110	2	M10
24	85110	2	M10
25	80826	4	M8 x 25
26	85008	4	M8
27	85109	4	M8
28	70068	2	
29	22648	1	
30	23244	1	L = 30
31	60223	2	
32	60216	2	
33	23338	1	
34	23304	1	
35	85108	2	M8
36	86108	2	M8
37	85112	2	M12
38	86212	2	M12
39	23268	2	L = 52
40	84714	11	6,3 x 19

92070/3

Afbeelding 4B : Dwarsband serie 04

Abbildung 4B : Querförderband Serie 04

Picture 4B : Side conveyor serie 04

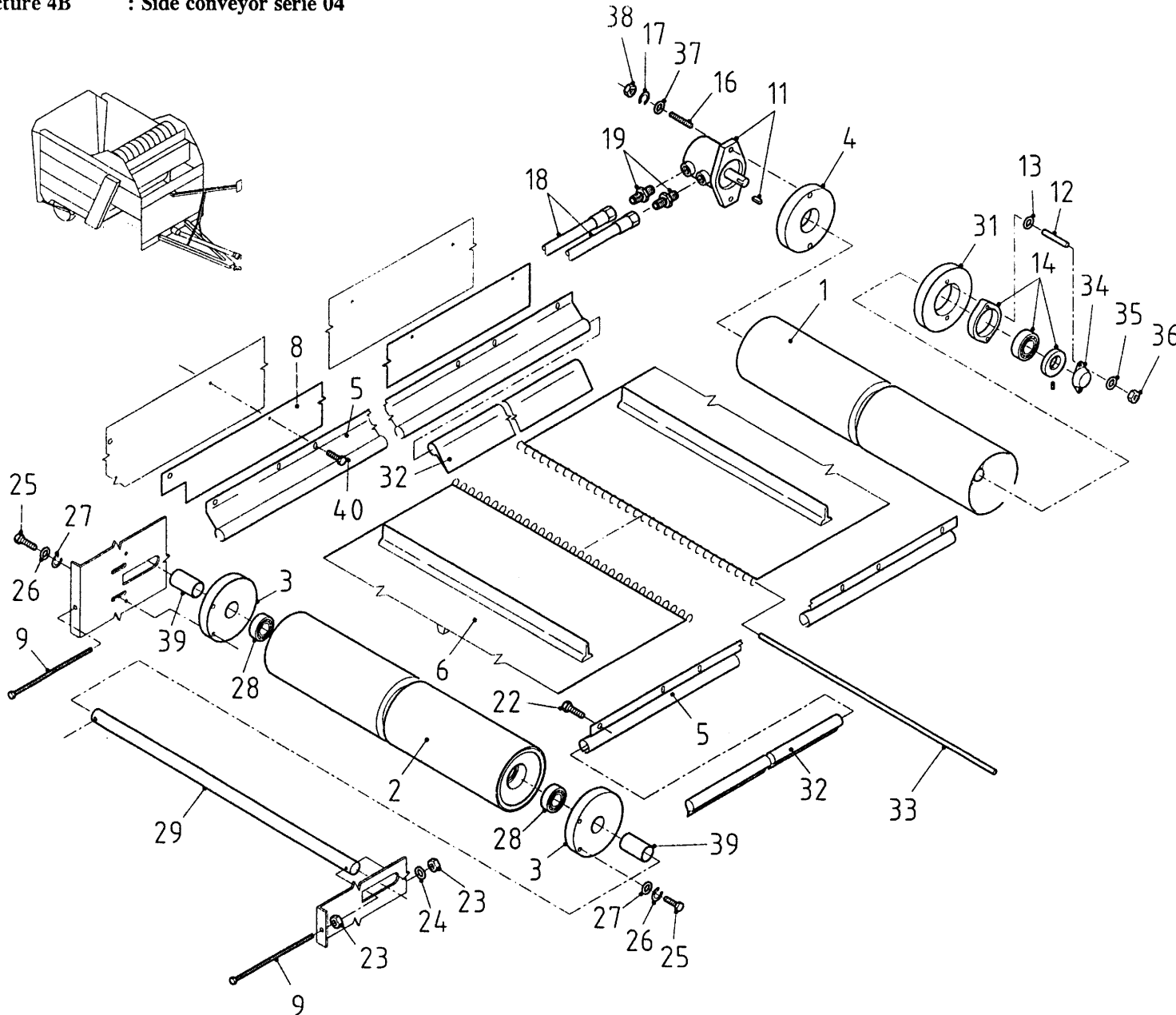

bestelnummer
 ordernummer
 num.à commander
 Bestellnummer

1	11726	1	
2	11136	1	
3	60224	2	
4	31543	1	
5	90274	2	
6	60173	1	
8	60229	1	
9	81017	2	M10 x 150
11A	50077	1	Danfos
11B	51084	1	White
12	84176	2	M8 x 60
13	85008	2	M8 x 70
14	70084	1	M8
15	88330	1	
16	84108	2	M12 x 60
17	85012	2	M12
18	W50916	2	½" 3300 RR
19	X50117	2	
22	84715	11	M6 x 16
23	86110	2	M10
24	85110	2	M10
25	80826	4	M 8 x 25
26	85008	4	M 8
27	85109	4	M 8
28	70068	2	
29	22648	1	
31	60223	2	
32	60216	2	
33	23338	1	
34	23304	1	
35	85108	2	M 8
36	86108	2	M 8
37	85112	2	M 12
38	86212	2	M 12
39	23268	2	L = 52
40	84716	11	M6 x 20

92070/3

Afbeelding 5A : Wielstel, enkel wiel
 Abbildung 5A : Radachse, standard
 Picture 5A : Wheelset, single wheel

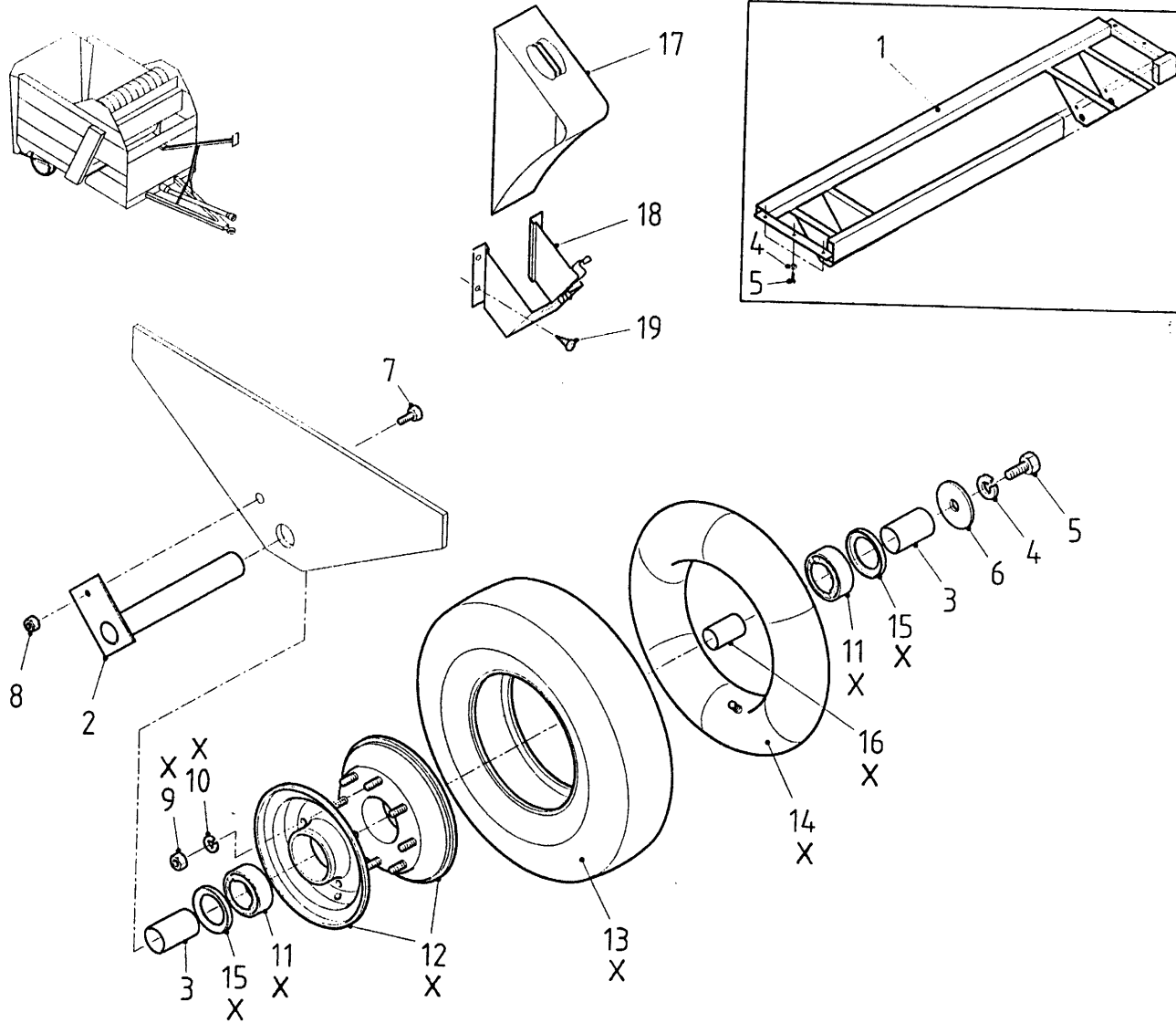

bestelnummer
 ordernummer
 num.à commander
 Bestellnummer

1	11276	1	→I 03
2	10498	2	
3	31216	4	L = 48
4	85012	2	M12
5	81221	2	M12 x 20
6	22445	2	
7	81226	2	M12 x 25
8	86212	2	M12
9	86926	20	M10
10	85010	20	M10
11	70010	4	6206 2RS
12	90134	2	4.00 Ex 910 PL
13	90135	2	6.00 x 9 12 PR
14	90136	2	500/600 9TR 15 TW
15	23105	4	
16	23296	2	
17	90396	2	
18	90397	2	
19	84715	4	M6 x 16
X	90131	2	

92070/3

Afbeelding 5B : Wielstel, dubbel wiel

Abbildung 5B : Radachse, Doppelräder

Picture 5B : Wheelset, double wheels

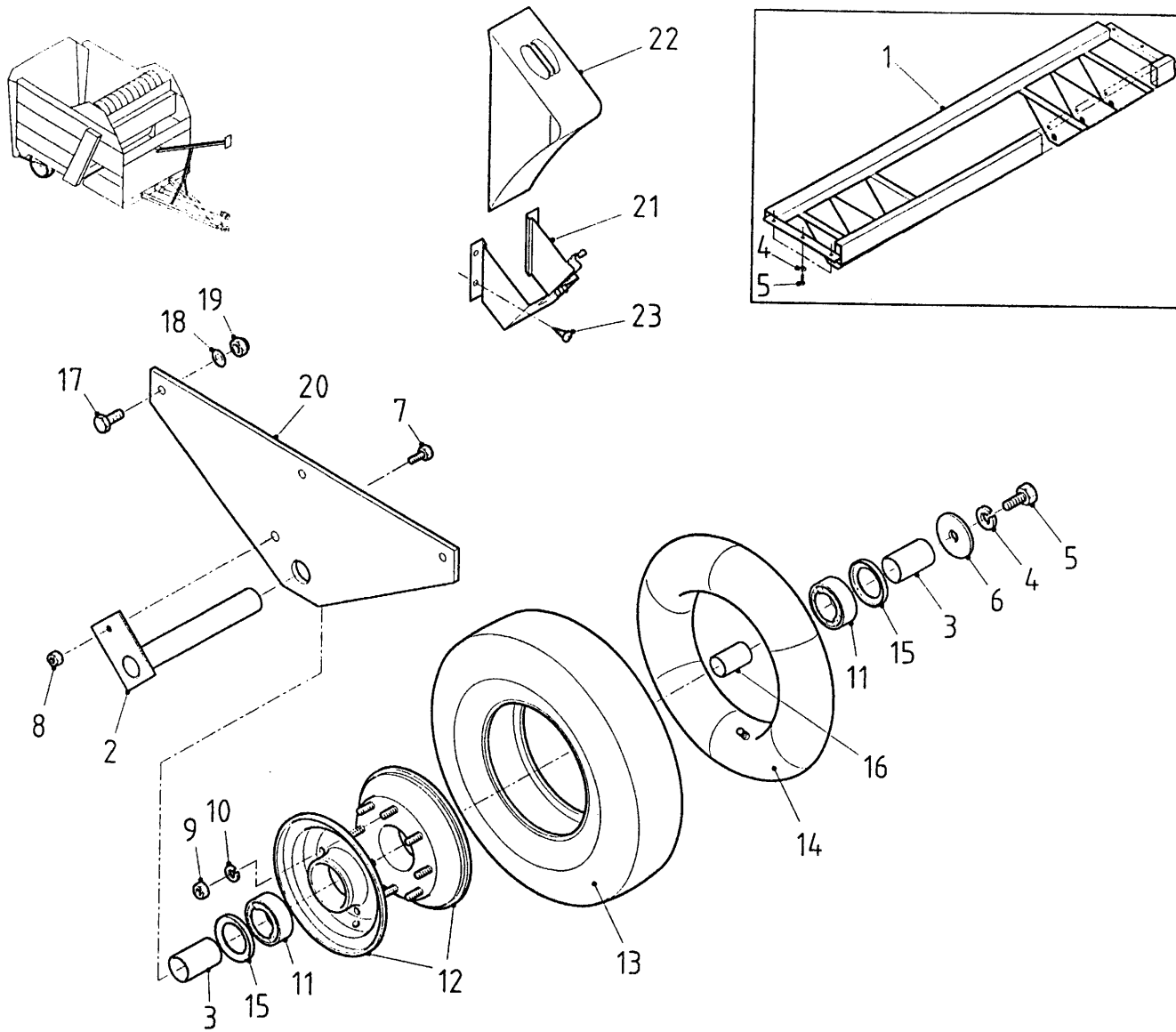

bestelnummer
ordernummer
num.à commander
Bestellnummer

1	11512		→1 03
2	11549	2	
3	31216	8	L = 48
4	85012	2	M12
5	81221	2	M12 x 20
6	22445	2	
7	81226	2	M12 x 25
8	86212	2	M12
9	86926	40	M 10
10	85010	40	M 10
11	70010	8	6206 2RS
12	90134	4	4.00 Ex 910 PL
13	90135	4	6.00 x 9 12 PR
14	90136	4	500/600 9 TR 15 TW
15	23105	8	
16	23296	4	
17	81036	6	M10 x 35
18	85110	6	M10
19	86210	6	M10
20	24486	2	↳ 04
21	90397	2	
22	90396	2	
23	84715	4	M6 x 16
X	90131	4	

92070/3

Afbeelding 6A : Trekboom 01 ↔ 03

Abbildung 6A : Deichsel 01 ↔ 03

Picture 6A : Drawbar 01 ↔ 03

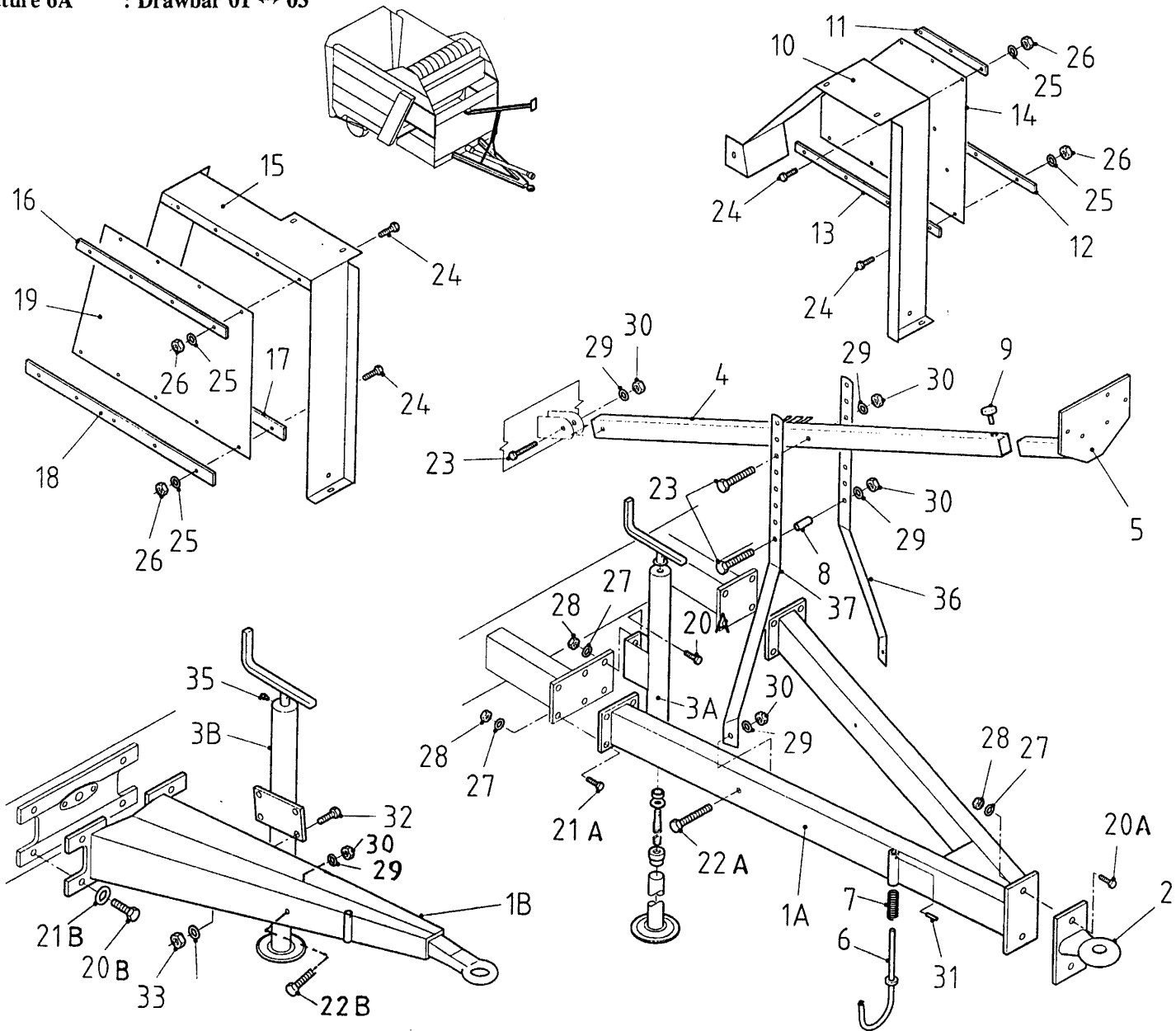

bestelnummer
ordernummer
num.à commander
Bestellnummer

1A	11359	1	serie 01+02
1B	11509	1	↳ 03
3A	11360	1	serie 01+02
3B	11510	1	↳ 03
4	11168	1	
5	11169	1	
6A	11352	1	serie 01+02
6B	11439	1	↳ 03
7	65061	1	
8	22748	1	
9	60215	1	
10A	23306	1	serie 01+02
10B	23906	1	↳ 03
11	22779	1	
12	22783	1	
13	22784	1	
14	60198	1	
15A	23299	1	serie 01+02
15B	23907	1	↳ 03
16	23300	1	
17	23301	1	
18	22780	1	
19	60230	1	
20A	81635	4	M16x35 serie 01+02
20B	82041	4	M20x40 ↳ 03
21A	81646	8	M16x45 serie 01+02
21B	85020	4	M20 ↳ 03
22A	81275	2	M12x75 serie 01+02
22B	81231	2	M12x30 ↳ 03
23	81280	3	M12x80
24	80625	16	M6x25
25	85106	16	M6
26	86206	16	M6
27	85116	12	M16 serie 01+02
28	86216	12	M16 serie 01+02
29	85112	8	M12
30	86212	5	M12
31	88028	1	Ø 5x28
32	81236	3	M12x35
33	86112	3	M12
35	89503	1	M6
36	22746	1	
37	22747	1	

92070/3

Afbeelding 6B : Trekboom ↳ serie 04

Abbildung 6B : Deichsel ↳ Serie 04

Picture 6B : Drawbar ↳ serie 04

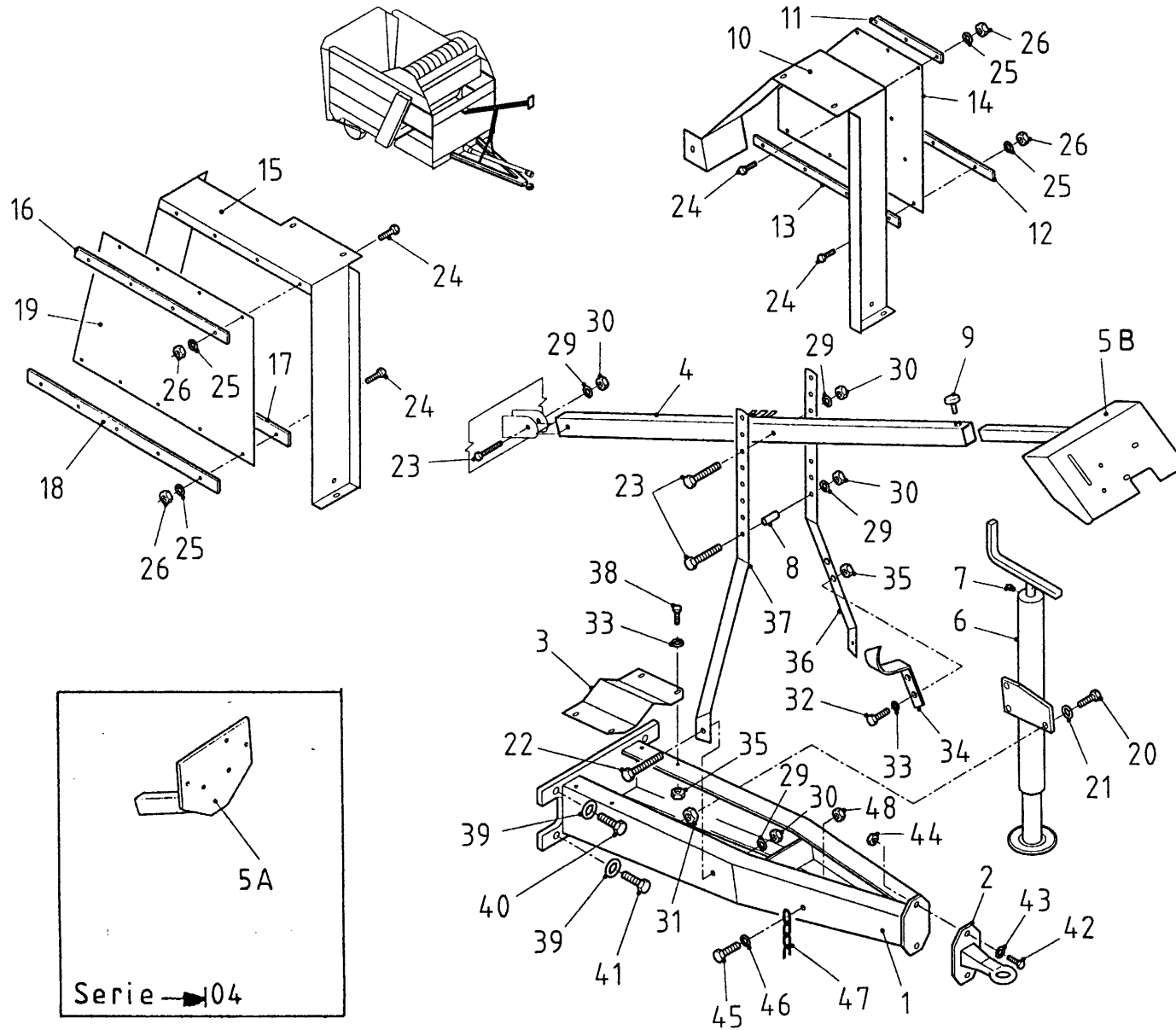

bestelnummer
ordernummer
num.à commander
Bestellnummer

1	11670	1	
2	11019	1	
3	24403	1	
4	11168	1	
5A	11169	1	serie 04
5B	11896	1	↳ 05
6	11510	1	
7	89503	1	
8	22748	1	
9	60215	1	
10	24564	1	
11	22279	1	
12	22783	1	
13	22784	1	
14	60198	1	
15	24563	1	
16	23300	1	
17	23301	1	
18	22780	1	
19	60230	1	
20	81236	3	M12 x 35
21	85112	3	M12
22	81231	2	M12 x 30
23	81280	3	M12 x 80
24	80626	16	M6 x 20
25	85106	16	M6
26	86206	16	M6
29	85112	5	M12
30	86212	5	M12
32	80826	2	M8x25
33	85108	6	M8
34	24569	1	
35	86208	6	M8
36	22746	1	
37	22747	1	
38	80821	4	M8 x20
39	85020	4	M20
40	82041	2	M20 x 30
41	82051	2	M20 x 50

92070/3

Afbeelding 6B : Trekboom ↳ serie 04

Abbildung 6B : Deichsel ↳ Serie 04

Picture 6B : Drawbar ↳ serie 04

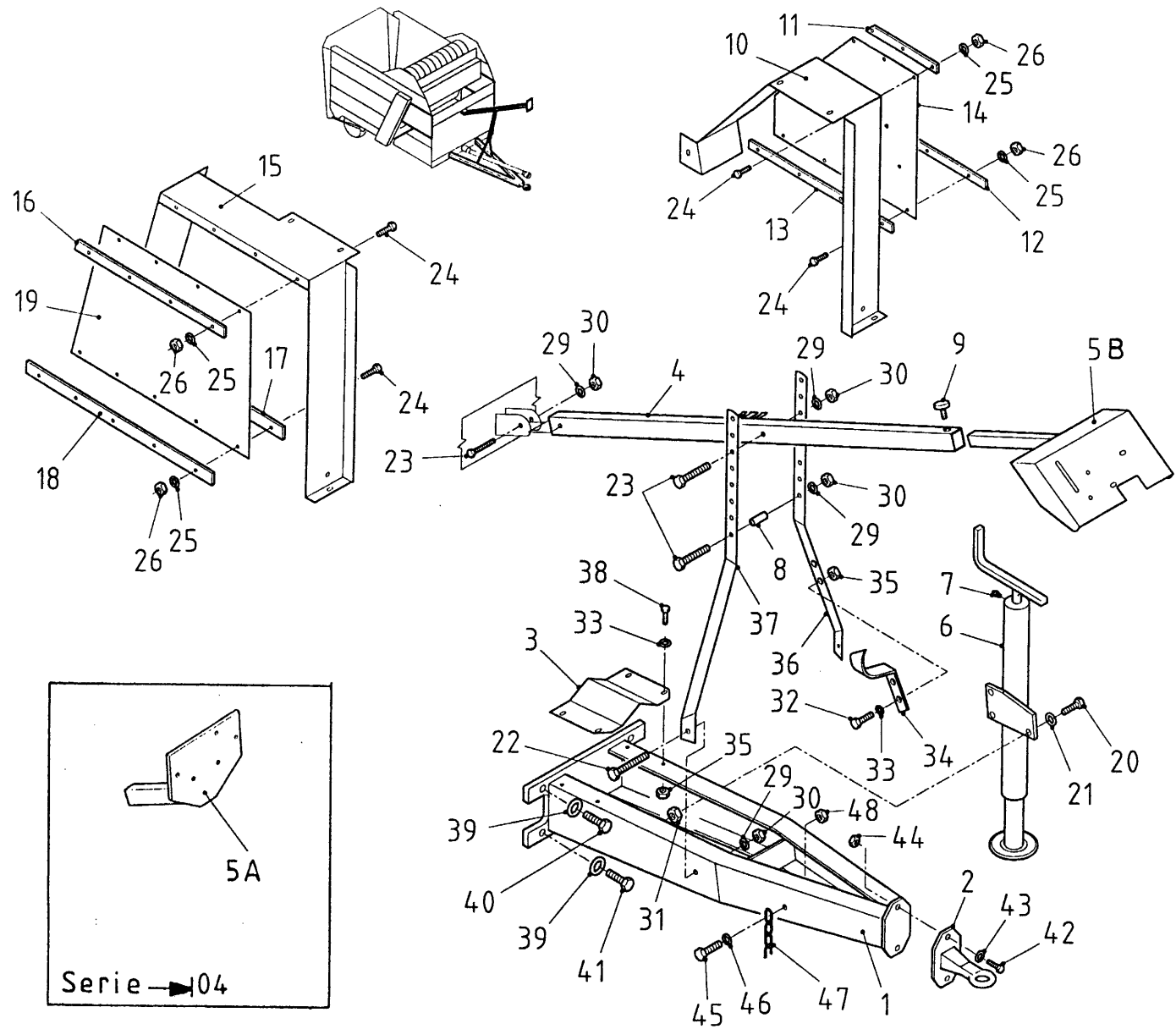

bestelnummer
 ordernummer
 num.à commander
 Bestellnummer

42	81646	2	M16 x 45
43	85116	2	M16
44	86212	2	M16
45	80626	1	M6 x 20
46	85107	1	M6
47	39136	1	
48	86206	1	M6

92070/3

Afbeelding 7 : Walsaandrijving

Abbildung 7 : Antrieb der Walze

Picture 7 : Gearbox and drive system

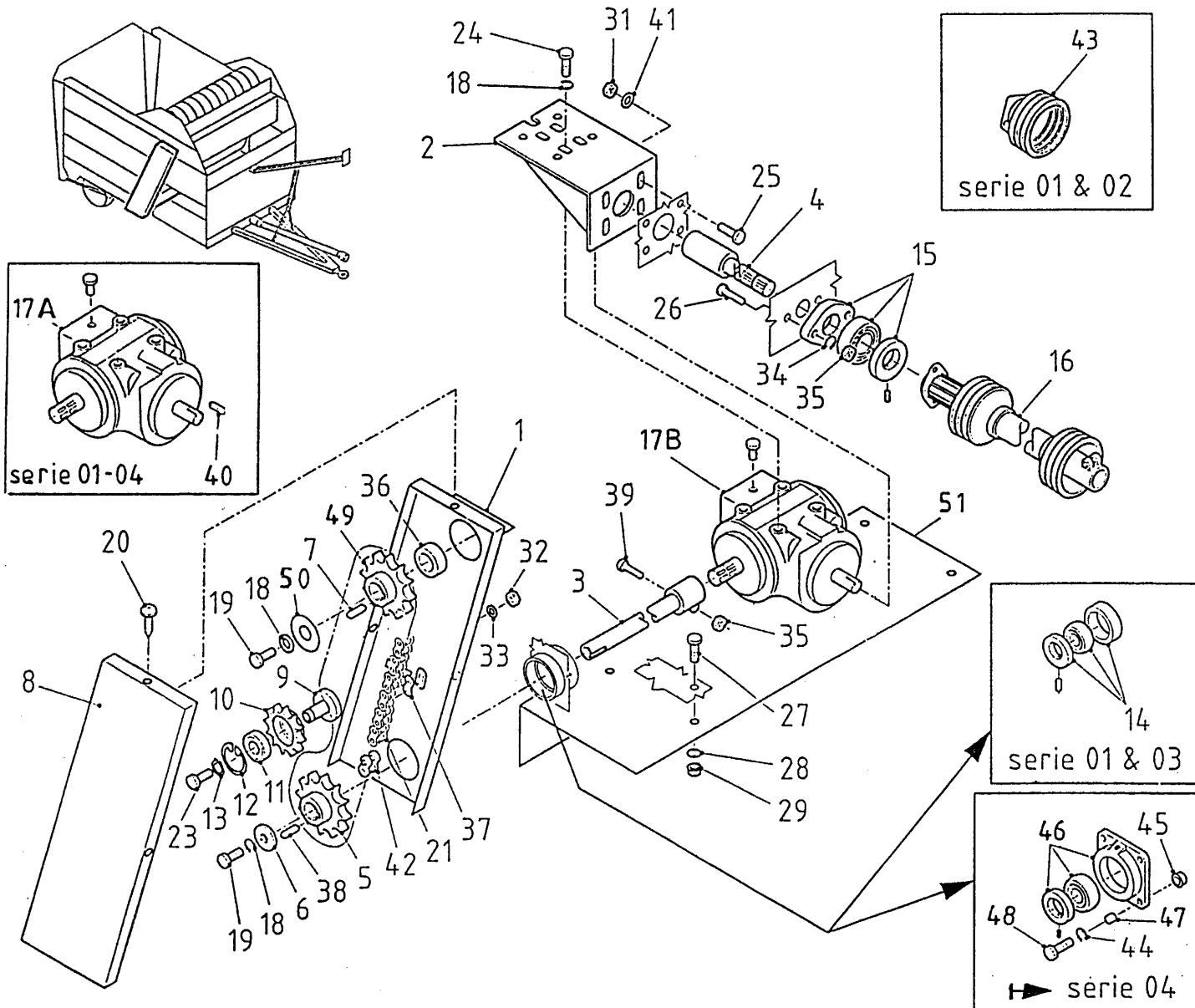

bestelnummer	ordernummer	num.à commander	Bestellnummer
1A	11361	1	→I 03
1B	11722	1	I→ 04
2A	11201	1	01↔04
2B	11895	1	I→ 05
3	11187	1	
4A	11186	1	01 ↔ 04
4B	11898	1	I→ 05
5	97071	1	
6	22445	1	
7A	88339	1	8 x 10 x 40 →I 03
7B	88349	1	9 x 14 x 40 I→ 04
8	23298	1	
9	31059	1	
10	97072	1	
11	70077	1	
12	87313	1	
13	87025	1	
14	70076	1	→I 03
15	70059	1	
16	90217	1	
17A	90219	1	(0,8L SAE 90) 01↔04
17B	90459	1	(1,1L SAE 90) I→04
18	85012	6	M 12
19	81231	2	M 12 x 30
20	84715	3	M6 x 16
21	39131	1	
23	81270	1	M12 x 70
24	81225	4	M12 x 25
25	81026	4	M 10 x 25
26	81040	2	M 10 x 40
27	80816	4	M 8 x 16
28	85108	4	M 8
29	86208	4	M 8
31	86210	4	M 10
32	86212	4	M 12
33	85119	1	M 12
34	85010	2	M 10
35	86110	3	M 10
36	31107	1	→I 03

92070/3

Afbeelding 7 : Walsaandrijving

Abbildung 7 : Antrieb der Walze

Picture 7 : Gearbox and drive system

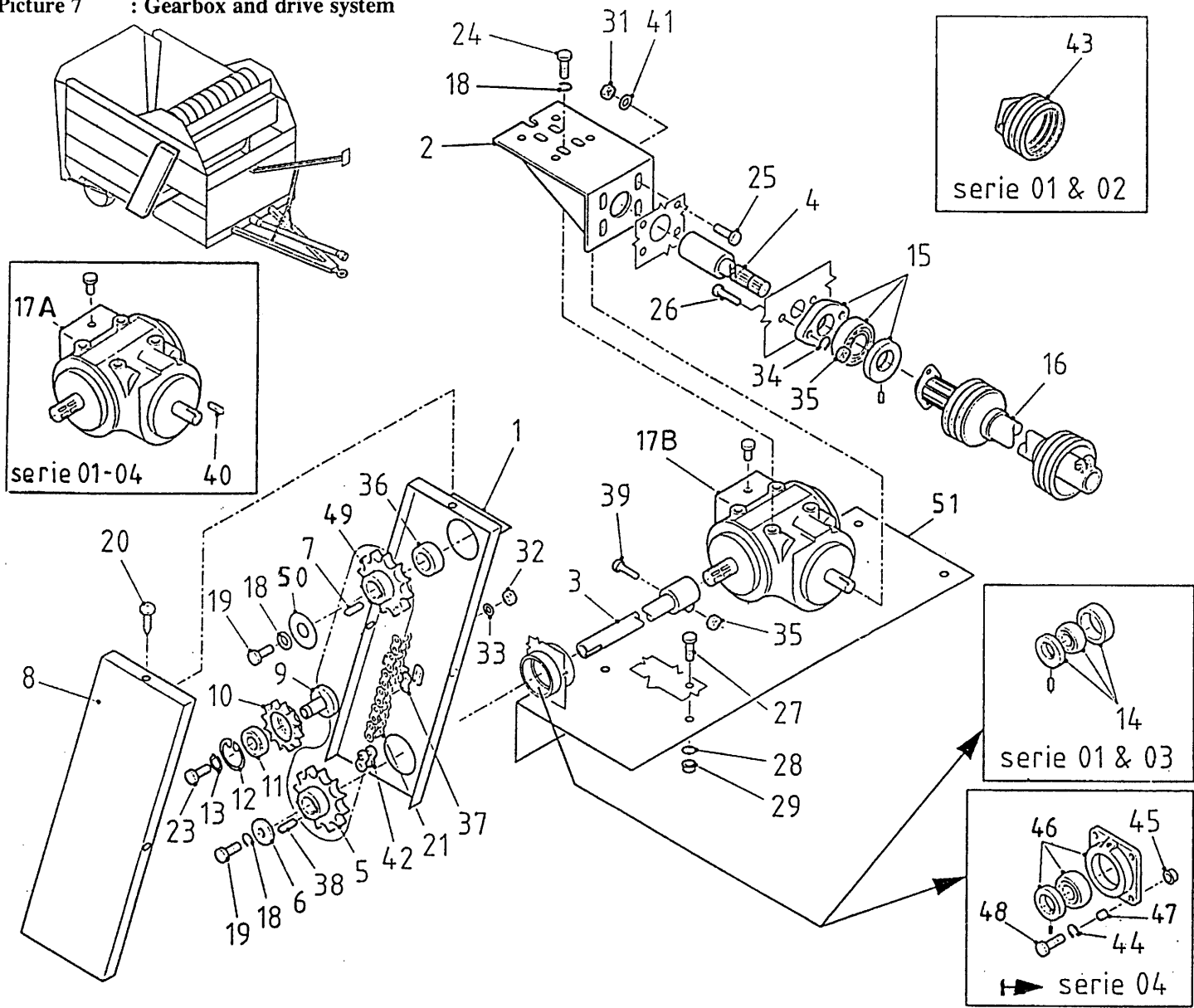

bestelnummer
ordernummer
num.à commander
Bestellnummer

37	39129	1	
38	88331	1	8 x 10 x 30
39	81070	1	M 10 x 70
40	88339	1	8 x 10 x 40 → 1 04
41	85110	4	M10
42	39130	1	
43	90284	1	
44	85012	4	M12
45	86212	4	M12
46	70121	1	
47	24578	4	
48	81236	4	M12 x 35
49A	97071	1	→ 03
49B	97103	1	→ 04
50A	22445	1	→ 03
50B	24586	1	→ 04

92070/3

Afbeelding 8A : Doseerwals 01 ↔ 03

Abbildung 8A : Dosierwalze 01 ↔ 03

Picture 8A : Roller 01 ↔ 03

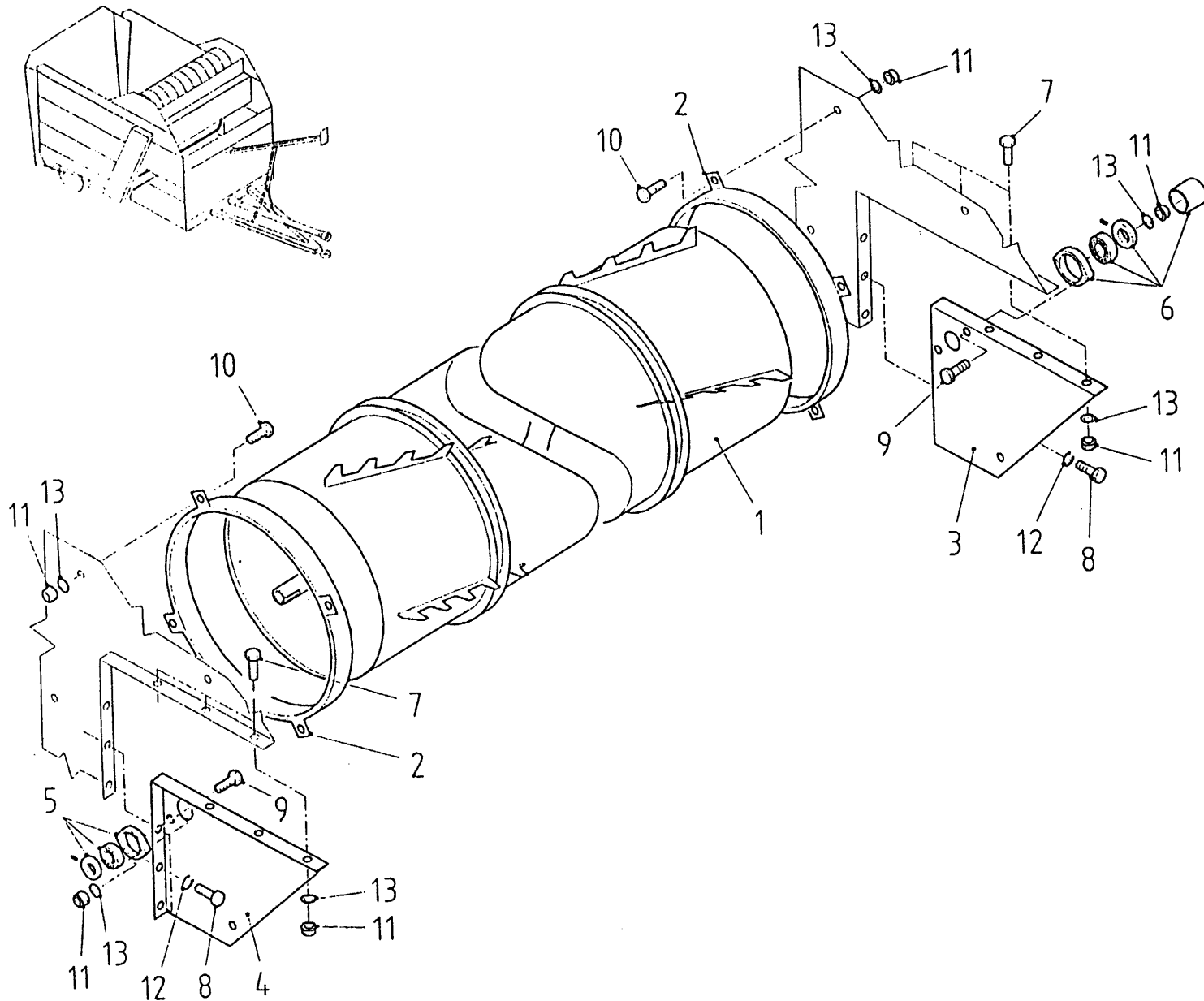

bestelnummer
ordernummer
num.à commander
Bestellnummer

1	11362	1	
2	11077	2	
3	22505	1	
4	22504	1	
5	70059	2	
7	81030	6	M10 x 30
8	81016	6	M10 x 16
9	81040	4	M10 x 40
10	81020	8	M10 x 20
11	86210	18	M10
12	85010	6	M10
13	85110	18	M10

92070/3

Afbeelding 8B : Doseerwals serie 04

Abbildung 8B : Dosierwalze Serie

Picture 8A : Roller serie 04

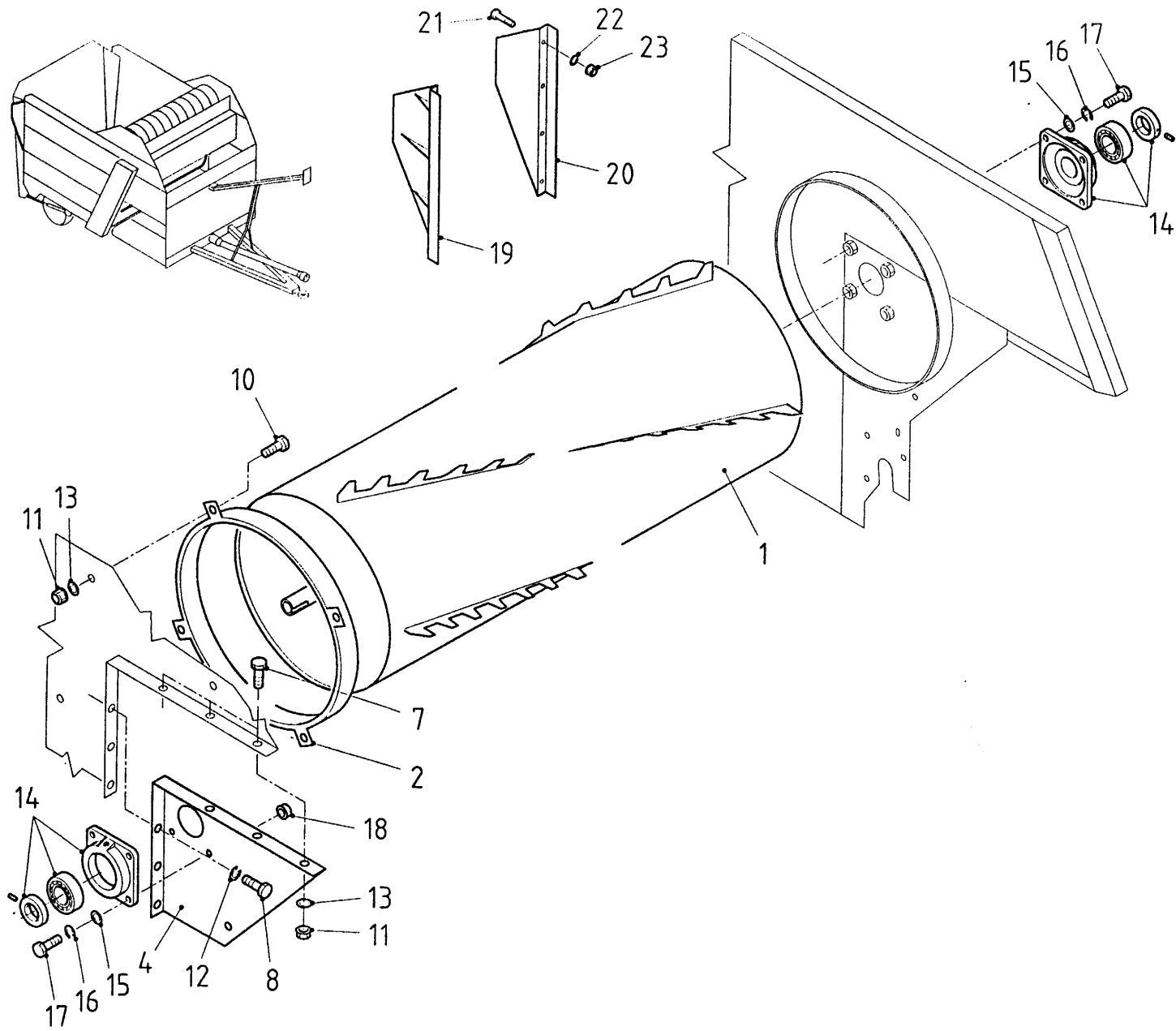

bestelnummer
ordernummer
num.à commander
Bestellnummer

1	11710	1	
2	11077	1	
4	24585	1	
7	81036	3	M 10 x 35
8	81021	7	M10 x 20
11	86210	7	M10
12	85010	3	M10
13	85110	7	M10
14	70081	2	
15	85112	8	M12
16	85012	8	M12
17	81236	8	M12 x 35
18	86216	4	M12
19	11728	1	
20	11727	1	
21	80880	8	M8 x 80
22	85108	8	M8
23	86208	8	M8

92070/3

Afbeelding 9 : Terugkrabrotor

Abbildung 9 : Gegenrotor

Picture 9 : Pick-up rotor

92070/3

Afbeelding 10A : Doseerrol, serie 02

Abbildung 10A : Stabwalze, serie 02

Picture 10A : Open roller, serie 02

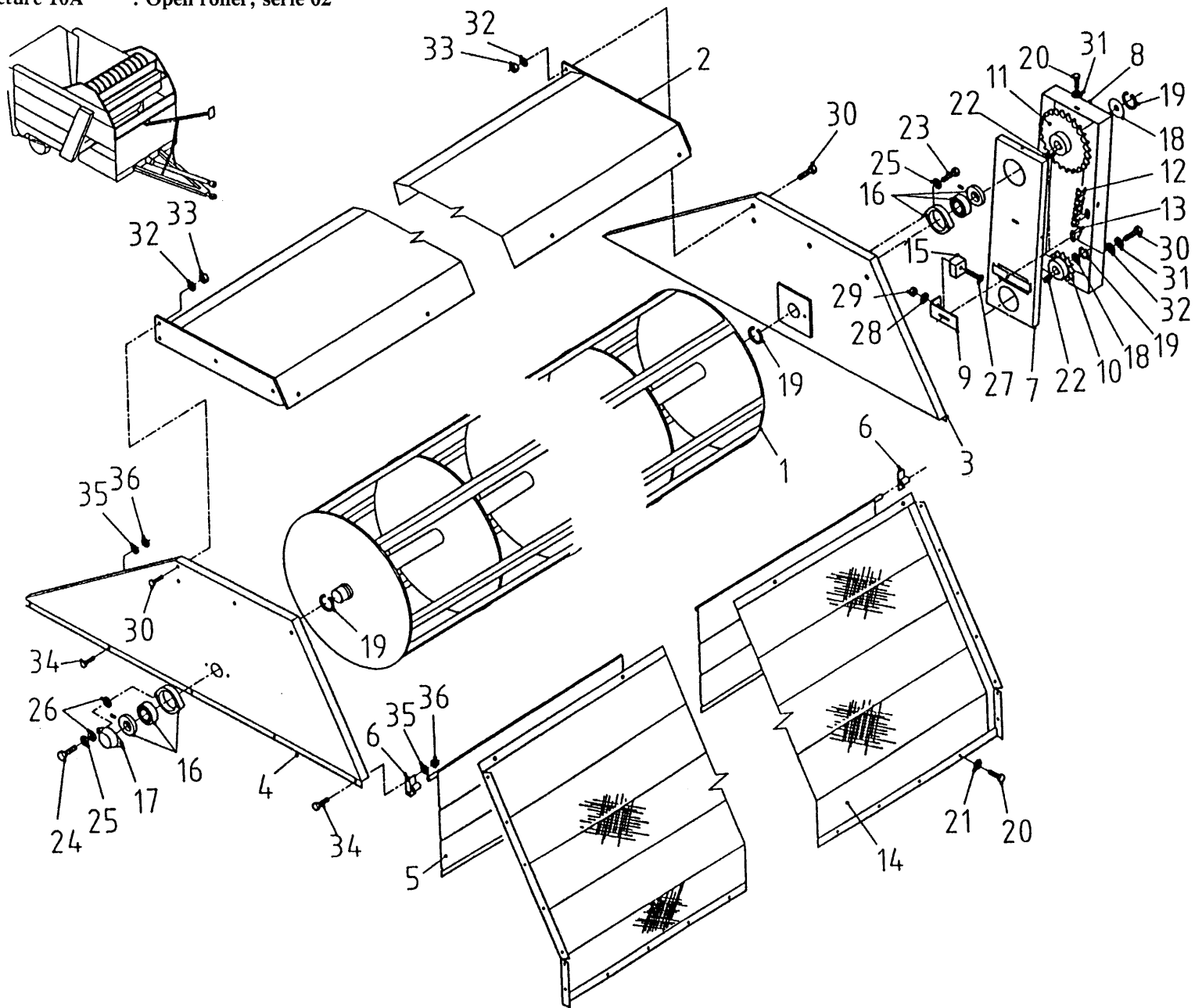

bestelnummer
ordernummer
num.à commander
Bestellnummer

1	11271	1	
2	11273	1	
3	11371	1	
4	11372	1	
5	11097	1	
6	11396	2	
7	11394	1	
8	23340	1	
9	23402	1	
10	97077	1	
11	97095	1	
12	39116	1	
13	39038	1	
14	40324	1	
15	60181	1	
16	70059	2	
17	23303	1	
18	85335	2	
19	87035	4	
20	84707	31	M 6,3 x 16
21	85106	31	M 6
22	88331	2	8 x 10 x 30
23	81041	2	M 10 x 40
24	81050	2	M 10 x 50
25	85010	4	M 10
26	85123	4	M 10
27	84153	1	M 10 x 40
28	85110	1	M 10
29	86210	1	M 10
30	81226	9	M 12 x 25
31	85012	1	M 12
32	85112	8	M 12
33	86212	8	M 12
34	80850	12	M 8 x 50
35	85108	12	M 8
36	86208	12	M 8

92070/3

Afbeelding 10B : Doseerrol serie 03

Abbildung 10B : Stabwalze Serien 03

Picture 10B : Open roller serie 03

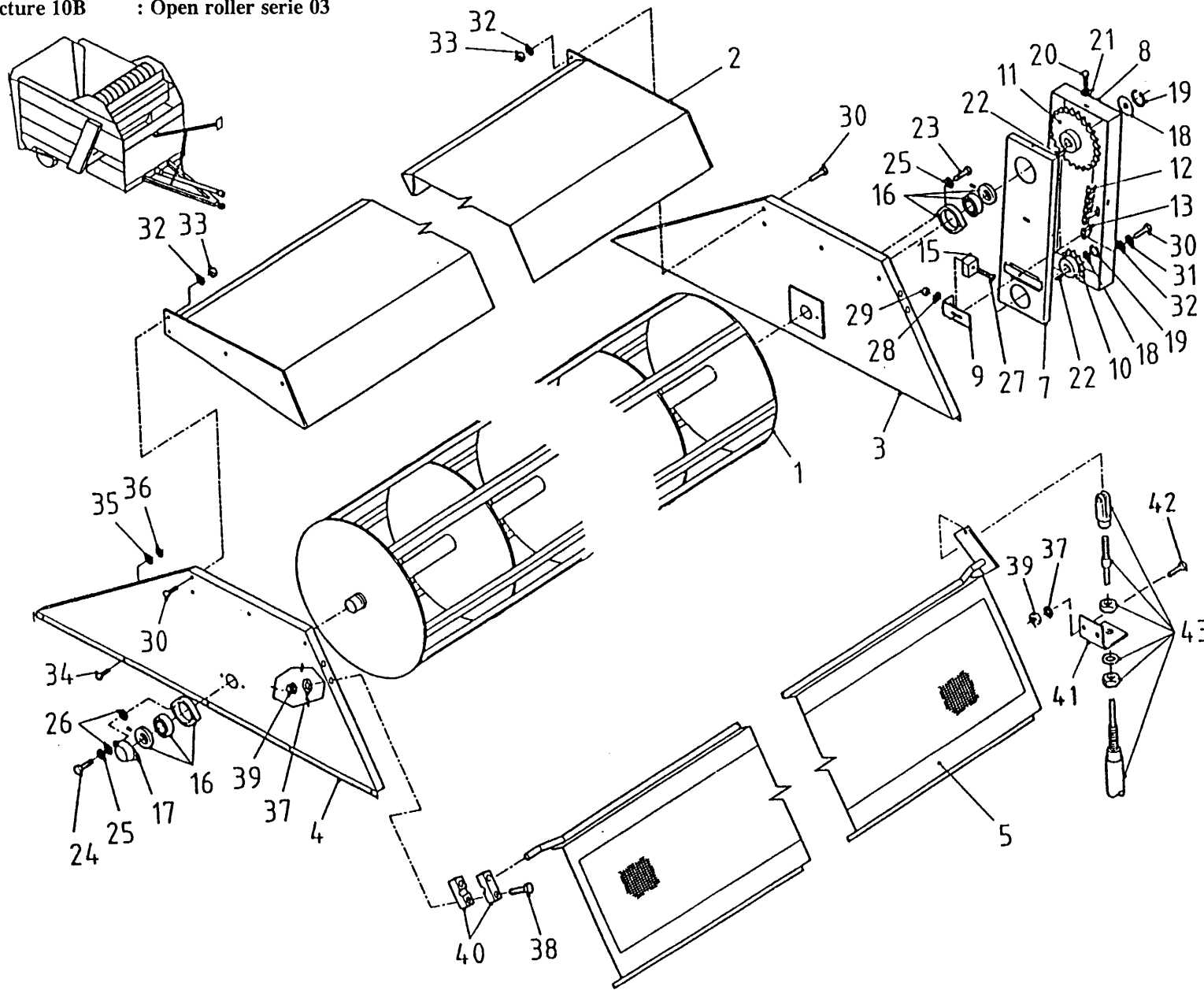

bestelnummer
ordernummer
num.à commander
Bestellnummer

1	11271	1	
2	11531	1	
3	11371	1	
4	11372	1	
5	11511	1	
6	11396	2	
7	11394	1	
8	23340	1	
9	23402	1	
10	97077	1	
11	97095	1	
12	39132	1	
13	39128	1	
15	60181	1	
16	70059	2	
17	23303	1	
18	85335	2	
19	87035	3	
20	84712	3	6,3 x 16
21	85106	3	M6
22	88331	2	8 x 10 x 30
23	81041	2	M10 x 40
24	81050	2	M10 x 50
25	85010	4	M10
26	85123	4	M10
27	84155	1	M12 x 40
28	85112	1	M12
29	86212	1	M12
30	81226	9	M12 x 25
31	85012	1	M12
32	85112	8	M12
33	86212	8	M12
34	80850	12	M8 x 50
35	85108	12	M8
36	86208	12	M8
37	85106	6	M6
38	84448	4	M6 x 40
39	86206	6	M6
40	90160	2	
41	23892	1	
42	80616	2	M6 x 16
43	79074	1	

92070/3

Afbeelding 10C : Doseerrol ↳ serie 04

Abbildung 10C : Stabwalze ↳ Serien 04

Picture 10C : Open roller ↳ serie 04

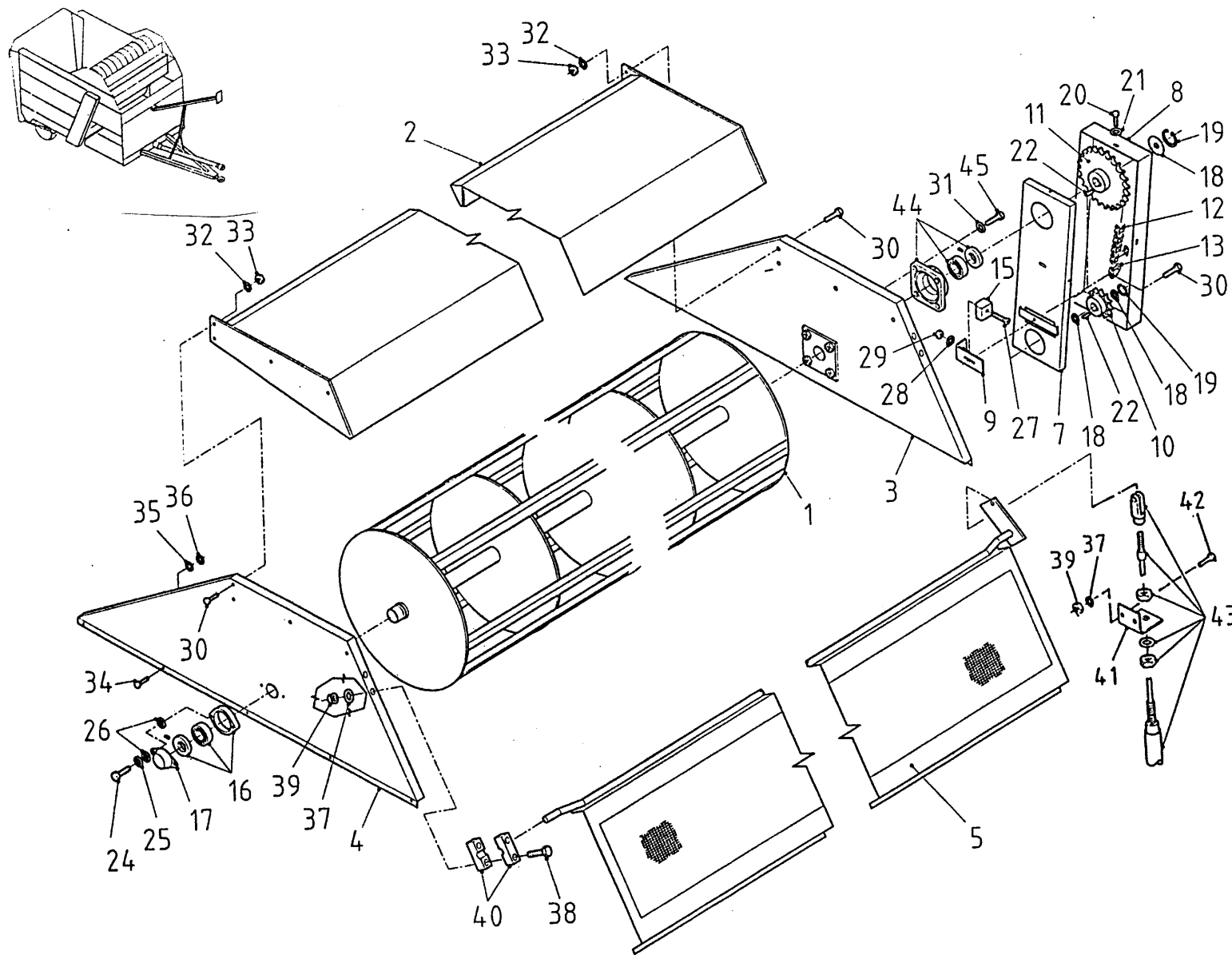

bestelnummer
ordernummer
num.à commander
Bestellnummer

1	11711	1	
2	11531	1	
3	11715	1	
4	11372	1	
5	11511	1	
7	11394	1	
8	23340	1	
9	23402	1	
10	97101	1	
11	97102	1	
12	39140	1	
13	39129	1	
15	60181	1	
17	23303	1	
18	85349	2	
19	87045	2	
20	84715	3	M6 X 16
21	85106	3	M6
22	88354	2	9 x 14 x 36
24	81050	2	M10 x 50
26	85123	4	M10
27	84155	1	M12 x 40
28	85112	1	M12
29	86212	1	M12
30	83937	8	M12 x 30
31	85012	4	M12
32	85112	8	M12
33	86212	8	M12
34	80850	12	M8 x 50
35	85108	12	M8
36	86208	10	M8
37	85106	6	M6
38	84448	4	M6 x 40
39	86206	6	M6
40	90160	2	
41	23892	1	
42	80616	2	M6 x 16
43	79074	1	
44	70081	1	
45	81236	4	M12 x 35

92070/3

Afbeelding 11 : Hydraulische bodemketting aandrijving 01 ↔ 03

Abbildung 11 : Hydraulische Bodenkettenantrieb 01 ↔ 03

Picture 11 : Hydraulic drive system 01 ↔ 03

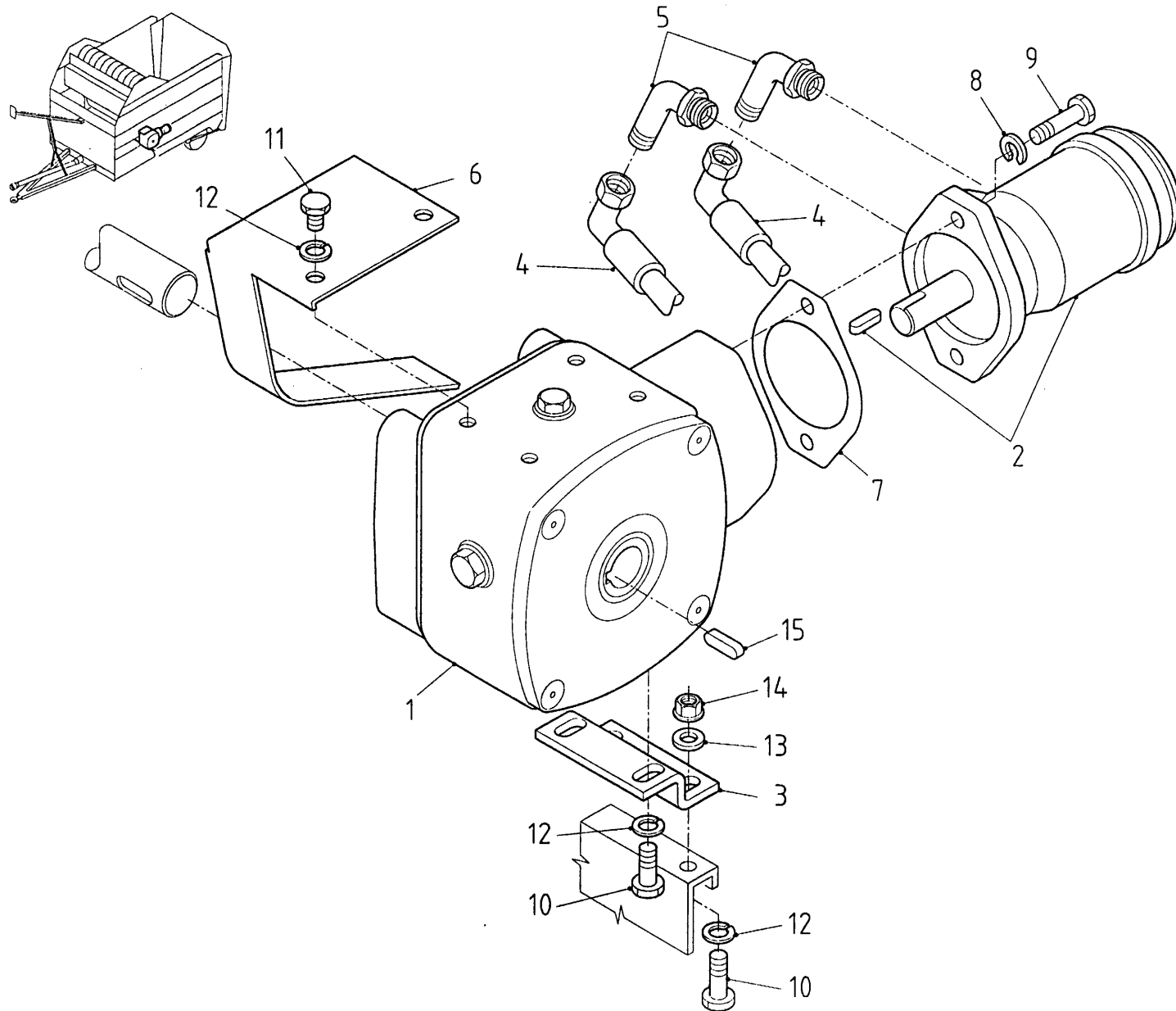

bestelnummer
 ordernummer
 num.à commander
 Bestellnummer

1	90297	1	(0,6 kg SAE90)
2A	50046	1	Danfoss
2B	50073	1	White
4	W50809	2	½" 3900 R 45°
5	X50123	2	
7	60231	1	
8	85012	2	M 12
9	81236	2	M 12 x 35
10	81026	4	M 10 x 25
11	81020	2	M 10 x 20
12	85010	6	M 10
13	85110	2	M 10
14	86210	2	M 10
15	88331	1	10 x 8 x 30

92070/3

Afbeelding 12 : Laadklepcilinder
Abbildung 12 : Ladeklappenzyylinder
Picture 12 : Cylinder Loading Platform

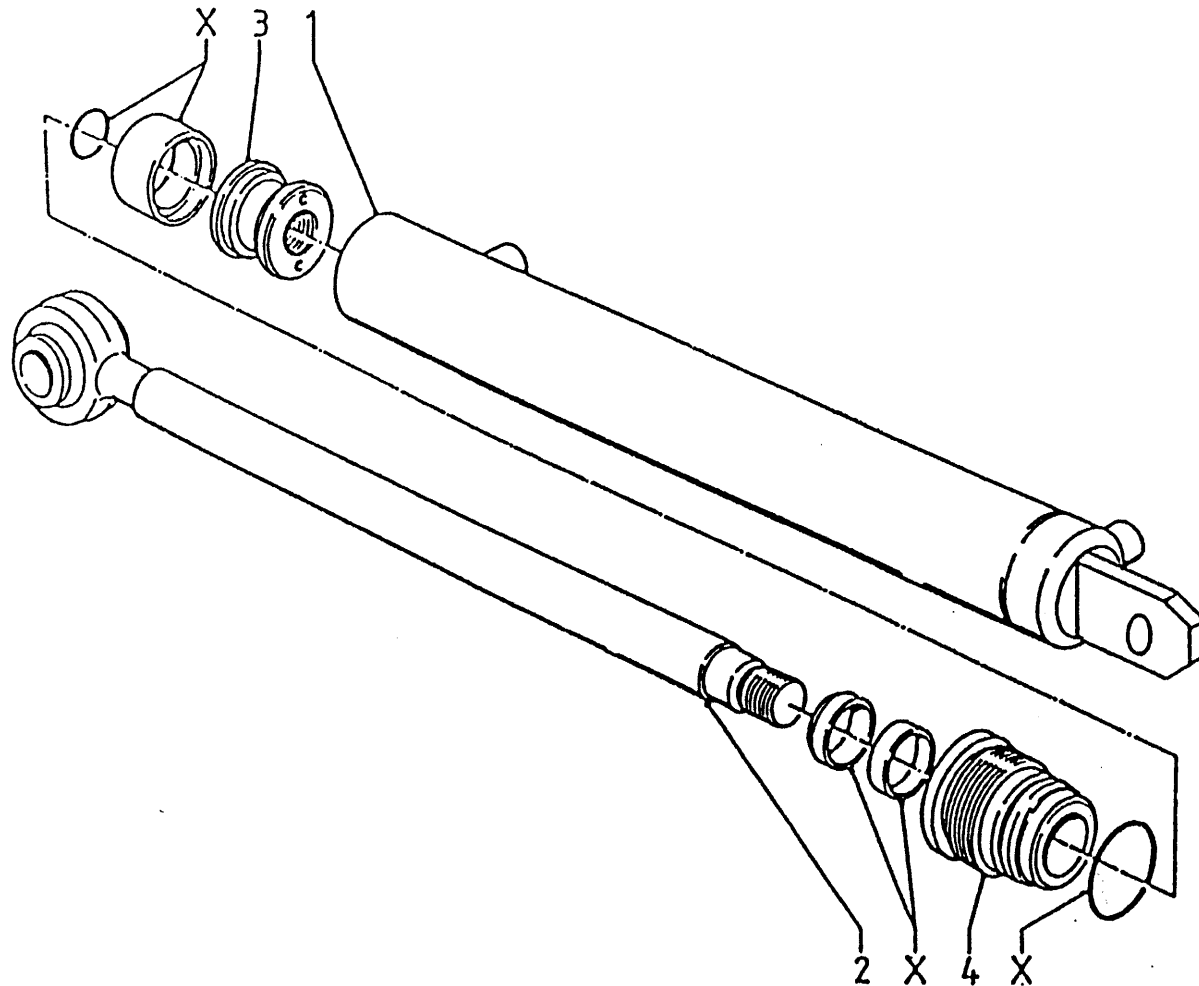

bestelnummer
ordernummer
num. à commander
Bestellnummer

1	11066	1
2	11067	2
3	30519	1
4	30520	1
X	05238	1

92070/3

Afbeelding 13A : 3-Handel stroomregelventiel
 Abbildung 13A : 3-Hebel Stromregelventil
 Picture 13A : 3-Handle-flow control valve

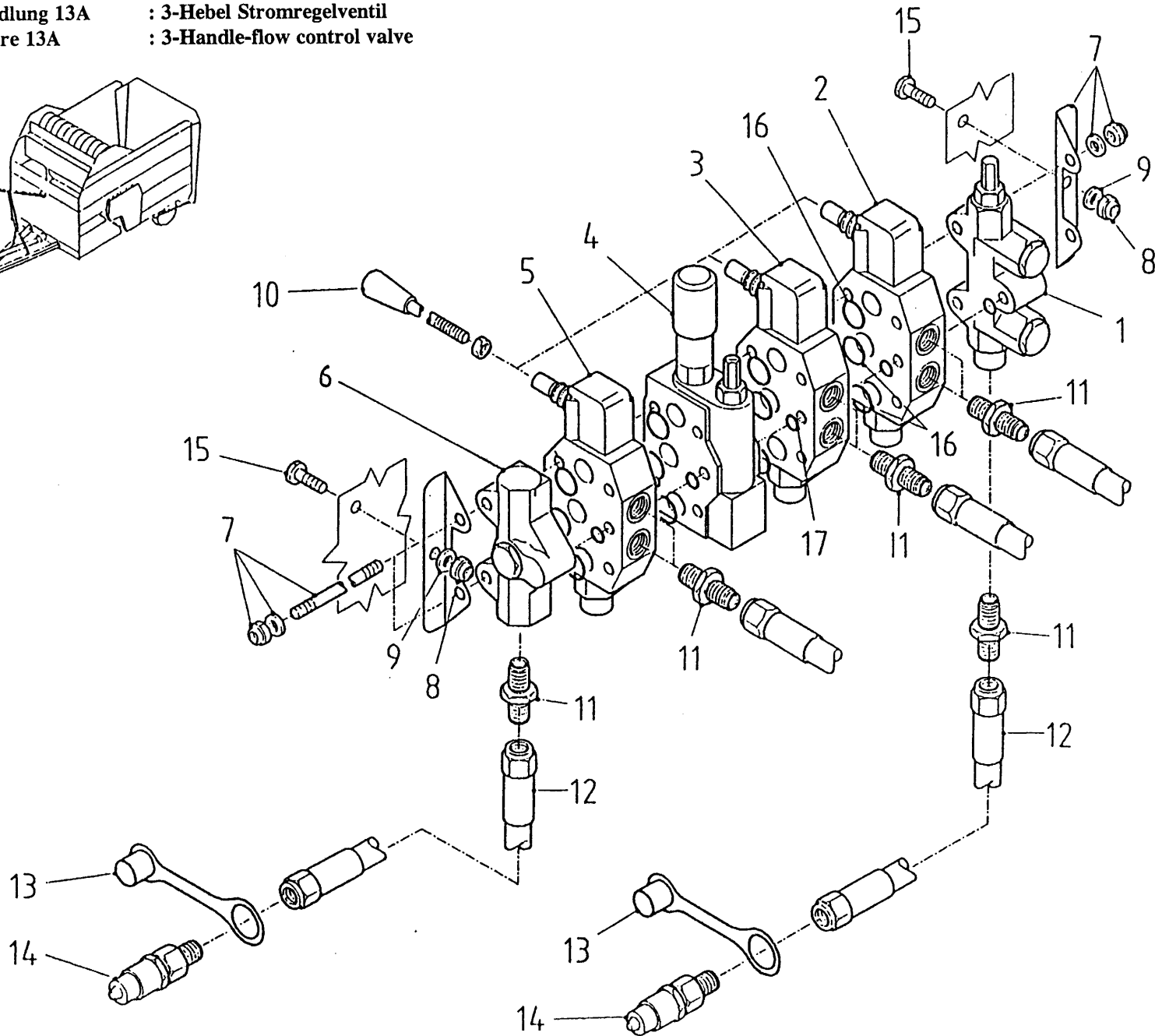
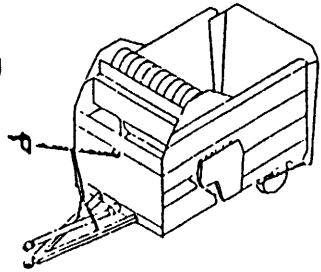

bestelnummer
 ordernummer
 num. à commander
 Bestellnummer

1	53108	1
2	53109	1
3	53110	1
4	53111	1
5	53112	1
6	53107	1
7	05193	1
8	86208	2 M 8
9	85108	2 M 8
10	53089	3
11	X50102	8
12	W50772	2 ½" 1400 RR
13	53303	2
14	53301	2
15	80821	2 M 8 x 20
16	78065	15
17	78066	5

92070/3

Afbeelding 13B

Abbildung 13B

Picture 13B

: 2-Handel stroomregelventiel

: 2-Hebel Stromregelventil

: 2-Handle-flow control valve

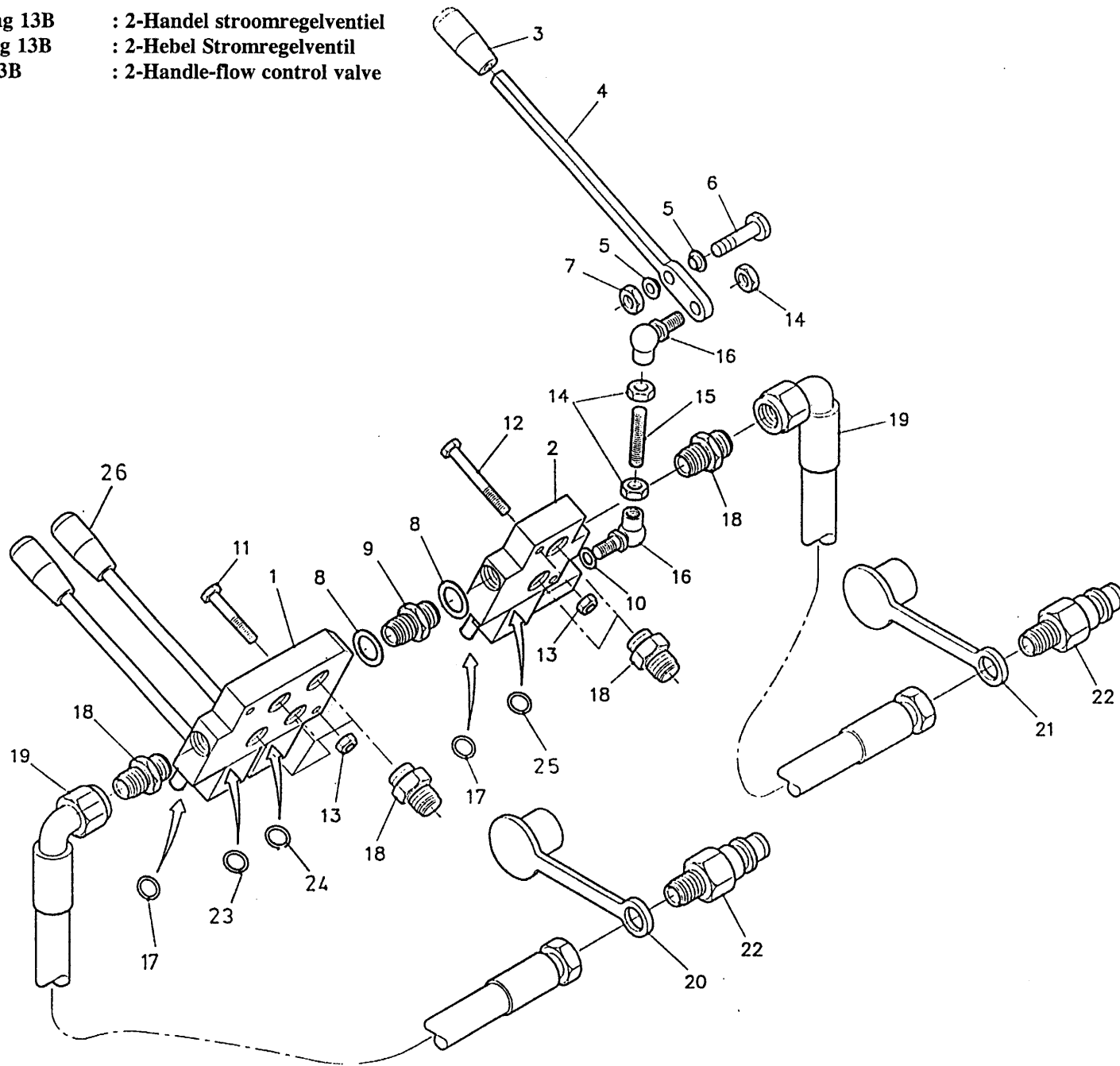

bestelnummer

ordernummer

num.à commander

Bestellnummer

1	53251	1	
2	53252	1	
3	60288	1	
4	25033	1	
5	85702	2	
6	81040	1	M10 x 40
7	86210	1	M10
8	85232	2	
9	50429	1	
10	85110	1	M10
11	80845	2	M8 x 45
12	80860	2	M8 x 60
13	86208	4	M8
14	86110	3	M10
15	84066	1	M10 x 90
16	70004	2	
17	78102	2	
18	X50102	8	
19	W50805	2	½" 1400 RH
20	53303	1	Rood
21	53326	1	Blauw
22	53301	2	
23	78126	1	
24	78127	1	
25	78128	1	
26	53268	2	

92070/3

Afbeelding 14 : Aftakas

Abbildung 14 : Zapfwelle

Picture 14 : PTO shaft

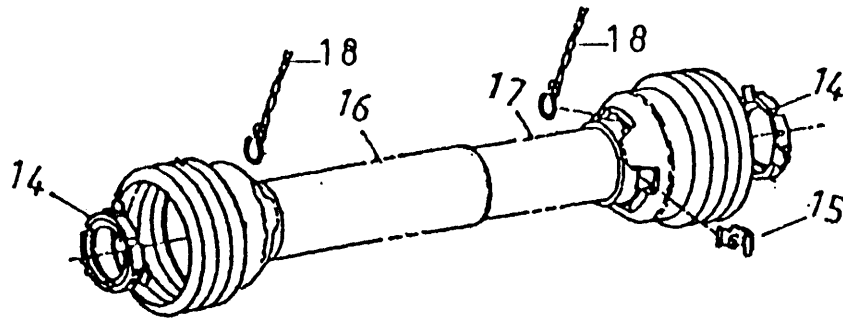
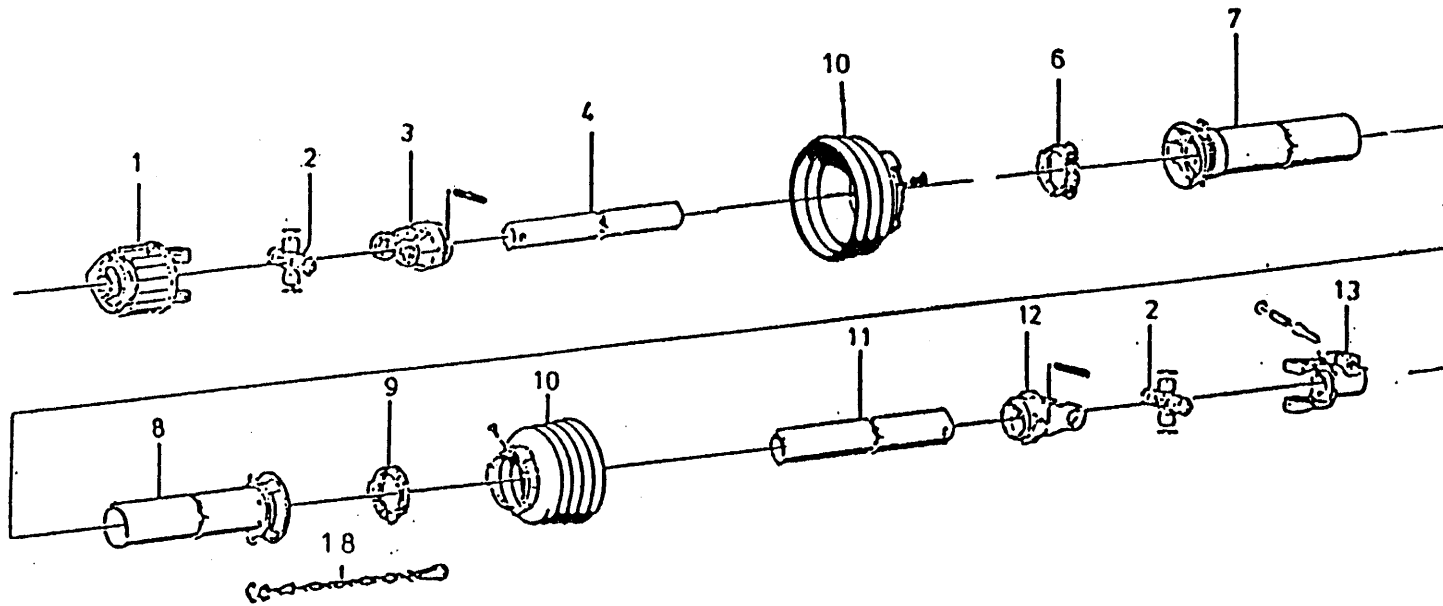

bestelnummer

ordernummer

num à commander

Bestellnummer

1A	90237	1	serie 01+02
1B	90352	1	↳ 03
2	90249	2	
3	90238	1	
4	90239	1	
6	90241	1	serie 01+02
7	90242	1	serie 01+02
8	90243	1	serie 01+02
9	90244	1	serie 01+02
10	90245	2	serie 01+02
11	90246	1	
12	90247	1	
13	90248	1	
14	90445	1	↳ 03
15	90349	2	↳ 03
16	90350	1	↳ 03
17	90351	1	↳ 03
18	90266	2	

92070/3

Afbeelding 15A : Hydraulisch schema

Abbildung 15A : Hydraulischer Schaltplan

Picture 15A : Hydraulic scheme

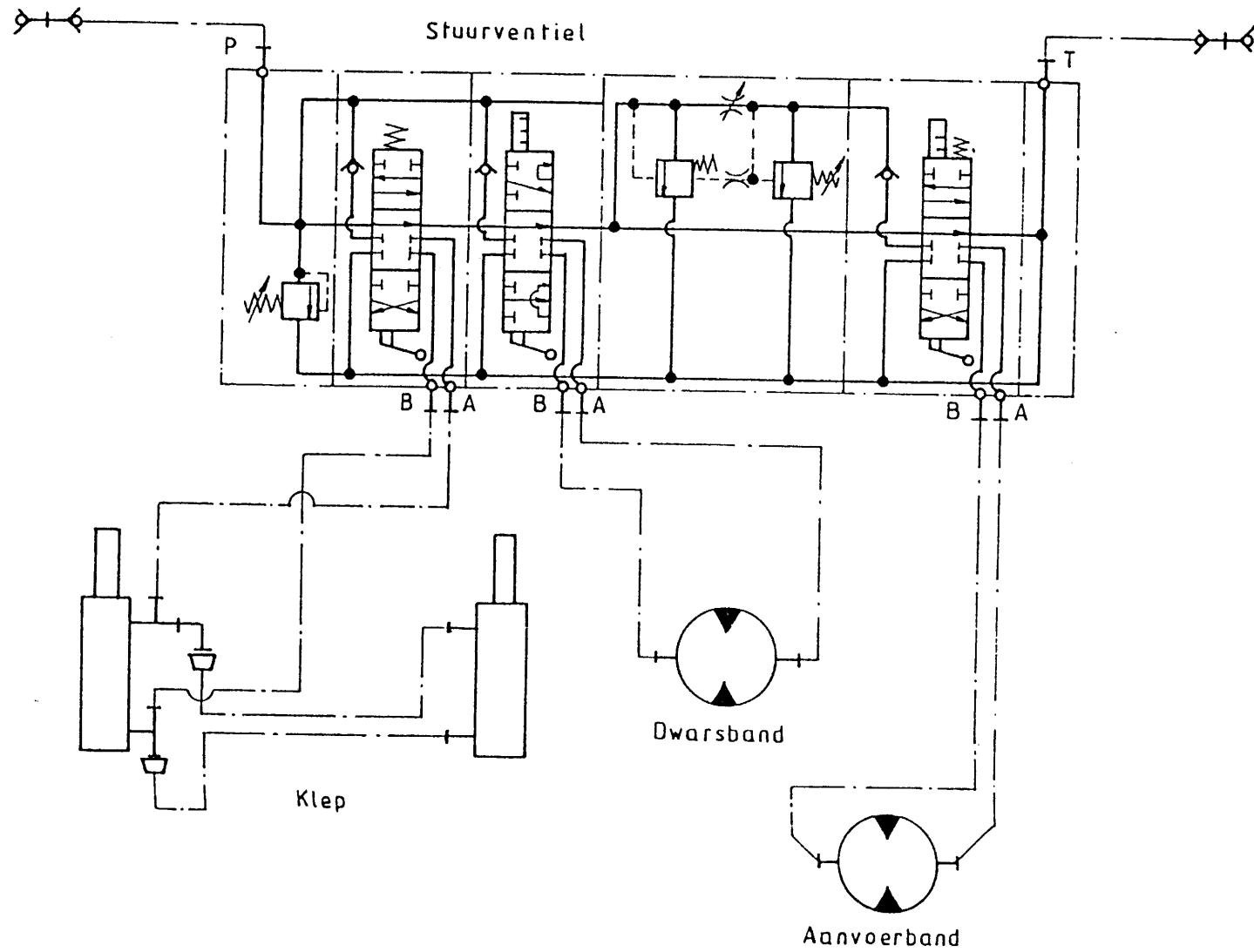

92070/3

Afbeelding 15B : Hydraulisch schema

Abbildung 15B : Hydraulischer Schaltplan

Picture 15B : Hydraulic scheme

KLEP

DWARSBAND

A ANVOERBAND

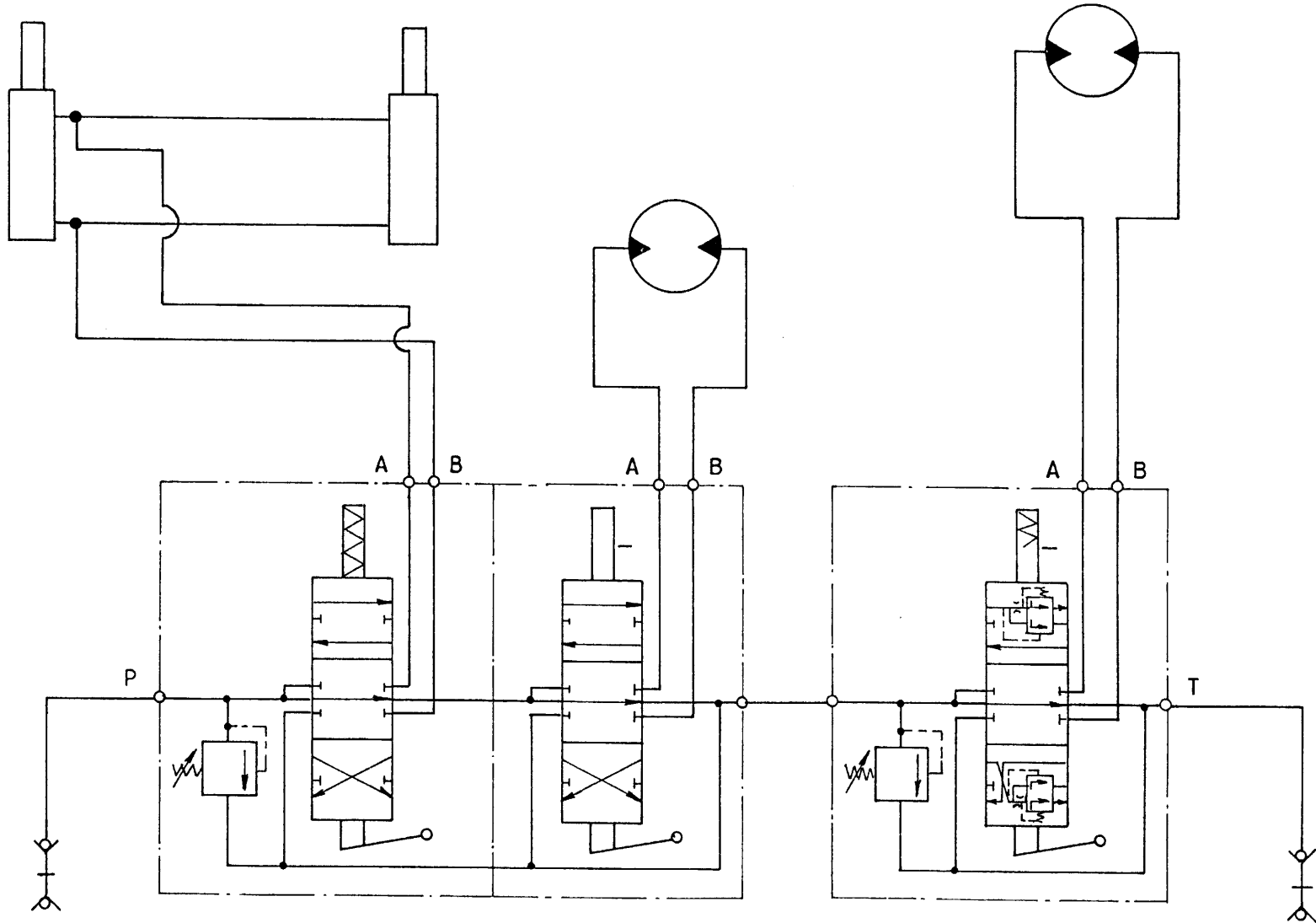



Trio liet Mullos B.V.

Himmanweg 19, 7575 BE Oldenzaal - Holland

Postbus 134 / Postfach 134, 7570 AC Oldenzaal - Holland

Tel.: 0541 - 57 21 21 / Tel.: (+)31 - 541 - 57 21 21

Fax 0541 - 57 21 25 / Fax (+) 31 - 541 - 57 21 25