

*Trioliet Mullos*

*Uitkuildoseermengwagen*

*Multimix*



*Onderdelenlijst / Ersatzteilliste*

*Sparepartslist / Liste de pièces de réchange*

*Bestelnummer / Bestellnummer 92064*

*Geldig vanaf productieserie nr. / Gültig ab Prod. Series No.: 02*

## INHOUDSOPGAVE

Afb.

1. Stickers  
Aufkleber
2. Frame  
Rahmen
3. Wielstel  
Radachse
4. Mengkettingaandrijving  
Mischkettenaandrieb
5. Aandrijving  
Antrieb
6. Tandwielkasten  
Getriebe
7. Teleskoop  
Teleskoparm
8. Snijstroom  
Schneidvorrichtung
9. Snijbordcomponenten  
Teile der Schneidplatte
10. Messcilinder  
Messerkolben
11. Stuurventielblok  
Ventilblock
12. Mechanische afstandsbediening  
Mechanische Fernbedienung
13. Elektrische bediening  
Elektrische Bedienung
14. Bedieningskast en aansluitschema  
Bedienungsgehäuse und Schaltplan
15. Schakelcilinder en zijklep-cilinder  
Schaltkolben und Seitenklappen-zylinder

16. Cilinders teleskoop  
Zylinder Teleskop
17. Dissel- en wielarmcilinder  
Deichsel- und Radarmzylinder
18. Afkassen  
Gelenkwellen
19. Elektronisch weegsystem  
Elektronische Waage
20. Hydraulisch schema mechanische bediening  
Hydraulischer Schaltplan mechanische Bedienung
21. Hydraulisch schema elektrische bediening  
Hydraulischer Schaltplan elektrische Bedienung
22. Elektrisch schema  
Elektrischer Schaltplan

**Afbeelding 1**  
**Stickers**  
**Aufkleber**

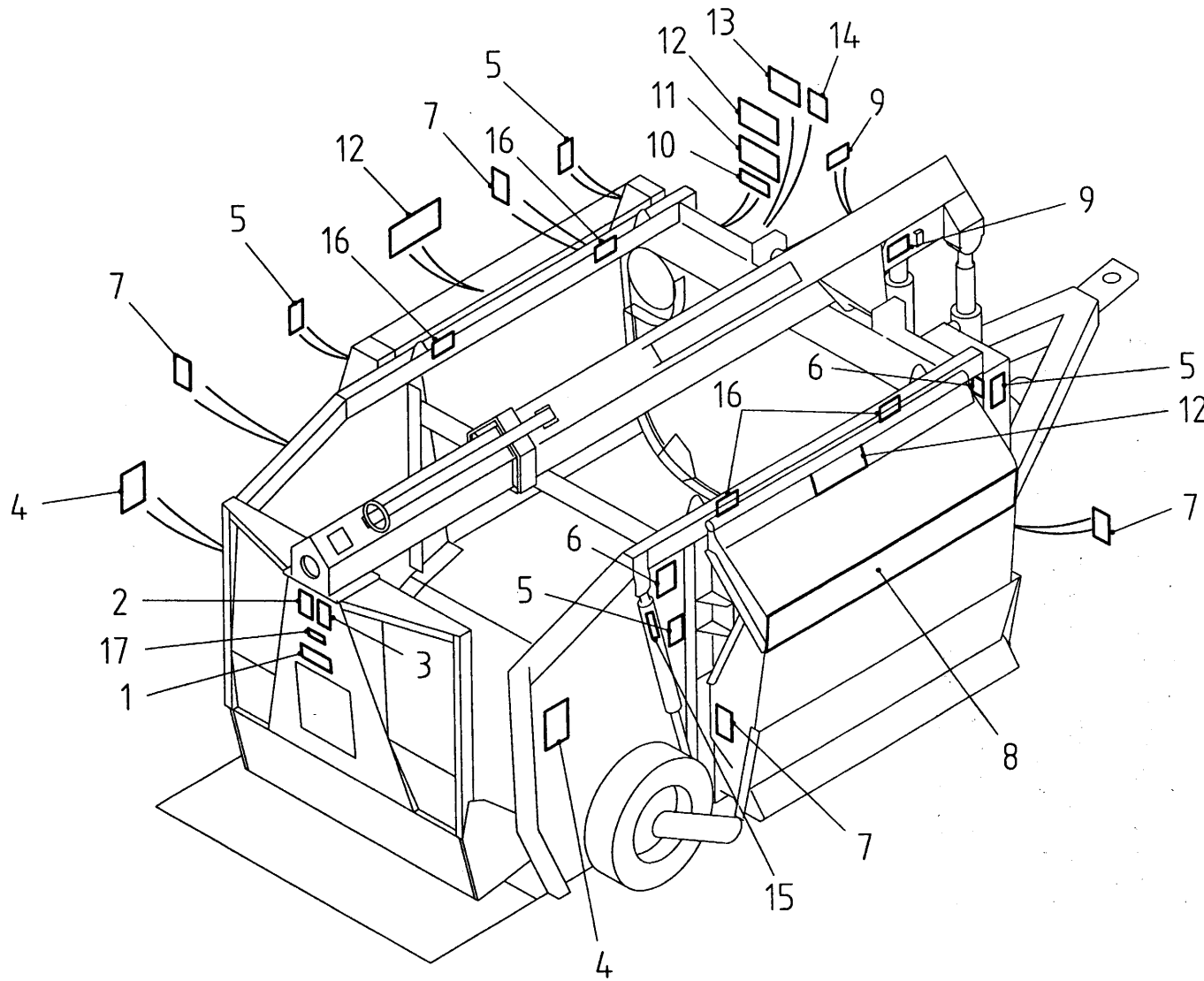

bestelnummer  
 ordernummer  
 num.à commander  
 Bestellnummer

1	91002	1
2	91153	1
3	91163	1
4	91172	2
5	91152	4
6	91014	2
7	91180	4
8	91178	2
9	91151	2
10	91159	1
11	91160	1
12	91164	3
13	91185	1
14	91190	1
15	91182	2
16	91183	4
17	91189	1

Afbeelding 2

Frame

Rahmen

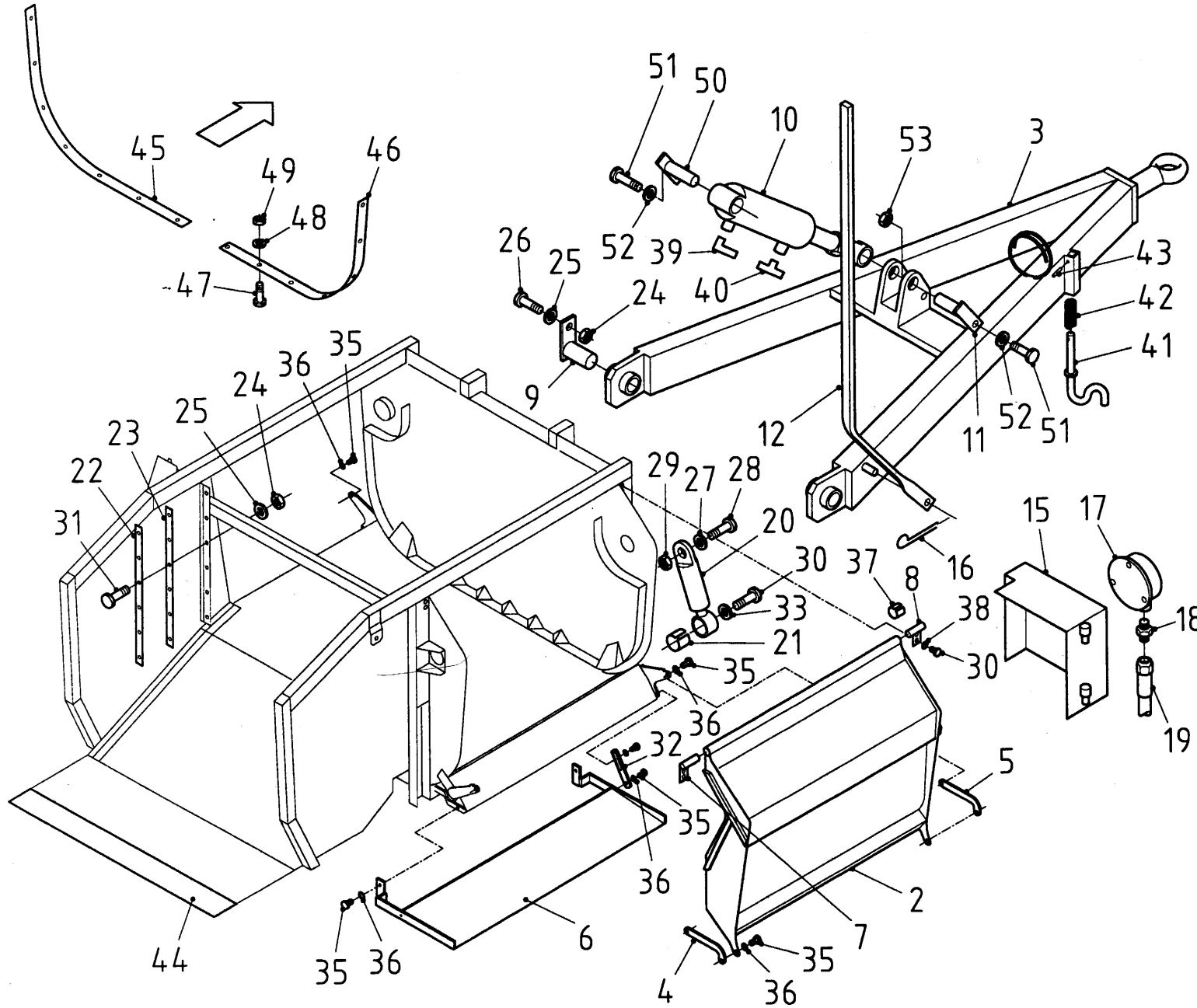

bestelnummer	ordernummer	num.à commander	Bestellnummer
1	11208	1	
2	11207	2	
3	11233	1	
4	11261	2	
5	11262	2	
6	11180	2	
7	11188	2	
8	11183	2	
9	11215	2	
10	51006	1	
11	11223	1	
12	22593	1	22953
13	22506	1	
14	65004	1	
15	22056	1	
16	88242	1	
17	53102	1	
18	X50415	1	
19	W50787	1	¼" L 600
20	50100	2	
21	51797	2	
22	22908	2	
23	60206	2	
24	86208	12	M 8
25	85108	12	M 8
26	80816	2	M 8 x 16
27	85116	2	M 16
28	81660	2	M 16 x 60
29	86216	2	M 16
30	81226	2	M 12 x 25
31	80826	10	M 8 x 25
32	22807	2	
33	85115	2	M 12
34	51747	2	
35	84919	16	
36	85121	16	M 16
37	51805	4	
38	85112	8	M 12
39	X50103	1	
40	X50356	1	

Afbeelding 2  
Frame  
Rahmen

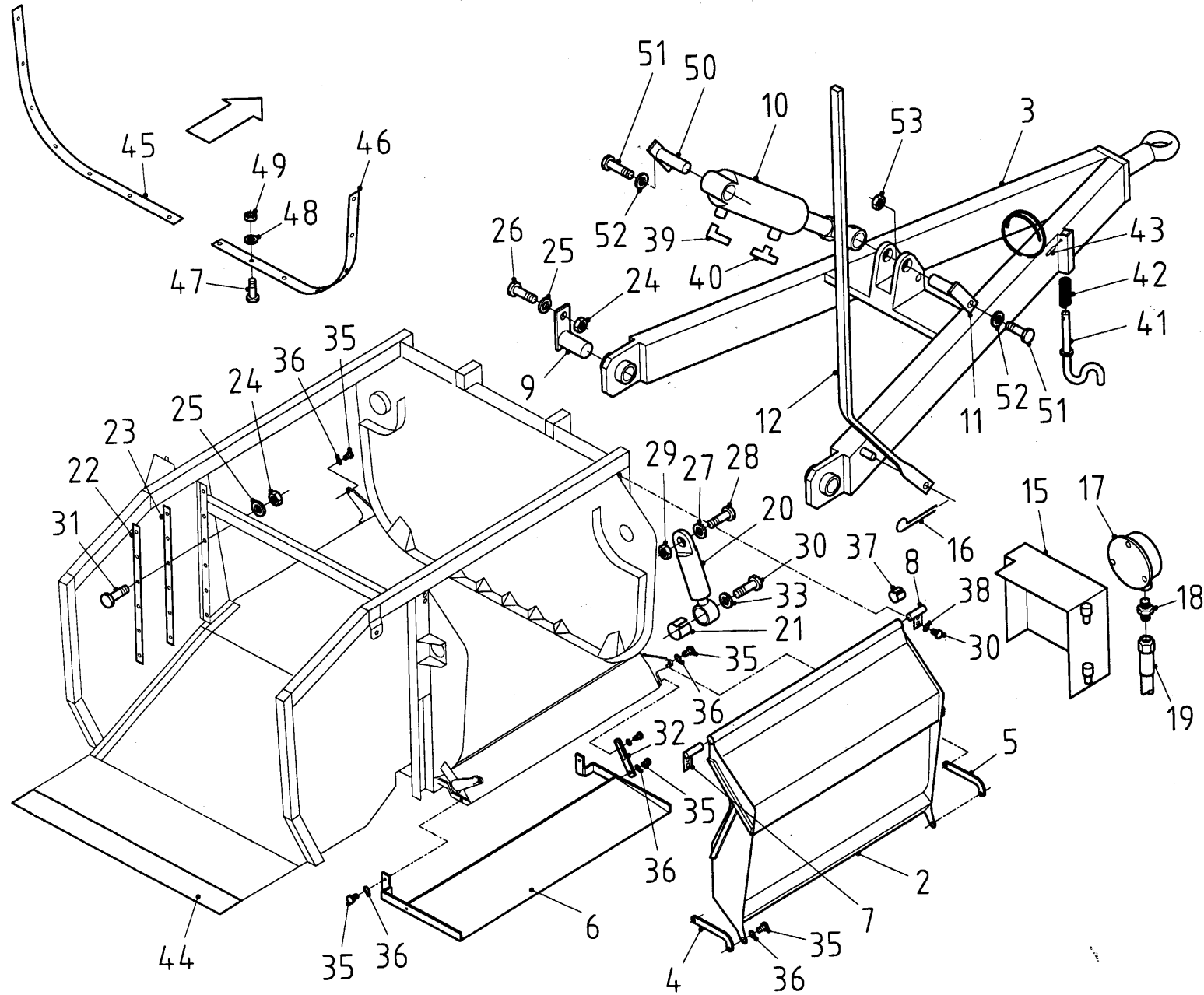

bestelnummer	ordernummer	num.à commander	Bestellnummer
41	11439	1	
42	65061	1	
43	88028	1	Ø 5 x 28
44	23225	1	
45	60226	2	Links
46	60227	2	Rechts
47	84144	32	M6 x 30
48	85106	32	M6
49	85206	32	M6 Nyloc
50	11225	1	
51	81030	2	M10 x 30
52	85110	2	M10
53	86210	1	M10 Nyloc

**Afbeelding 3**  
Wielset  
Radachse

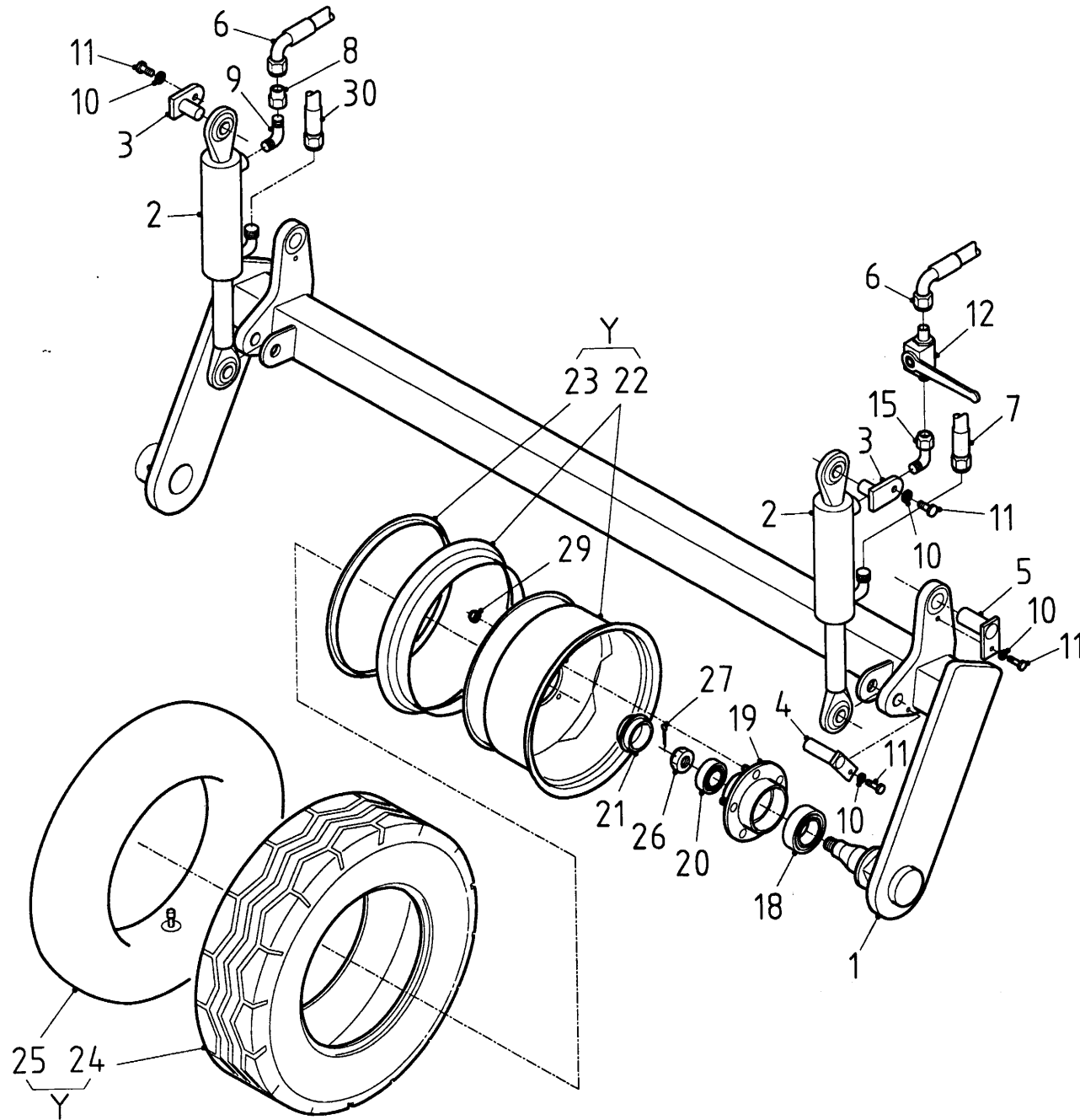

bestelnummer	ordernummer	num.à commander	Bestellnummer
1	11173	1	
2	51002	2	
3	11215	2	
4	11198	2	
5	11204	2	
6	W50795	2	$\frac{3}{8}$ L=3550
7	W50785	1	$\frac{3}{8}$ L=4500
8	X50154	1	
9	X50101	1	
10	85108	4	M 8
11	80816	4	M 8 x 16
12	51023	1	
15	50103	1	
18	70057	2	
19	90212	2	
20	70056	2	
21	90225	2	
22	90288	2	
23	90292	2	
24	90290	2	
25	90291	2	
26	90223	2	
27	90224	2	
29	86922	12	
30	W50796	1	$\frac{3}{8}$ L=5050
Y	90289	2	

**Afbeelding 4**  
**Mengkettingaandrijving**  
**Mischkettenantrieb**

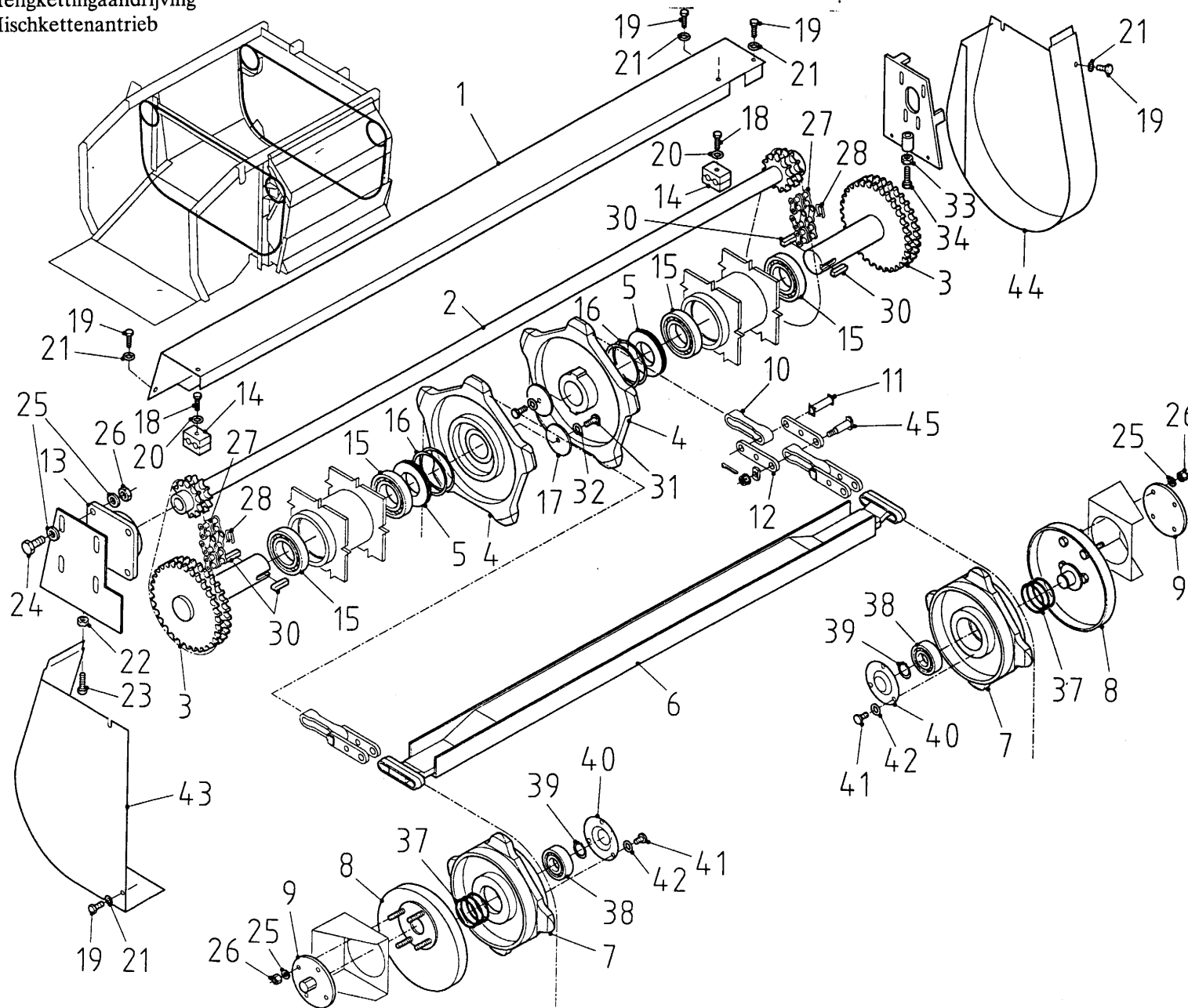

Bestellnummer	ordernummer	num.à commander	Bestellnummer
1	40318	1	
2	11331	1	
3	11330	2	
4	39109	2	
5	31093	2	
6	11366	5	11336
7	39110	2	
8	11344	2	
9	10807	2	
10	39101	116	
11	39102	116	
12	39100	232	
13	70081	1	
14	90159	2	
15	70079	4	
16	70080	2	
17	22608	2	
18	80851	2	M 8 x 50
19	80612	11	M 6 x 12
20	85108	2	M 8
21	85106	11	M 6
22	86112	1	M 12
23	81239	1	M 12 x 140
24	81241	4	M 12 x 40
25	85112	8	M 12
26	86212	4	M 12
27	39098	2	
28	39099	2	
30	88337	4	
31	81025	2	M 10 x 25
32	85110	2	M 10
33	86116	1	M 16
34	81690	1	M 16 x 90
37	70066	2	
38	70075	2	
39	87035	2	



**Afbeelding 4**  
**Mengkettingaandrijving**  
**Mischkettenantrieb**

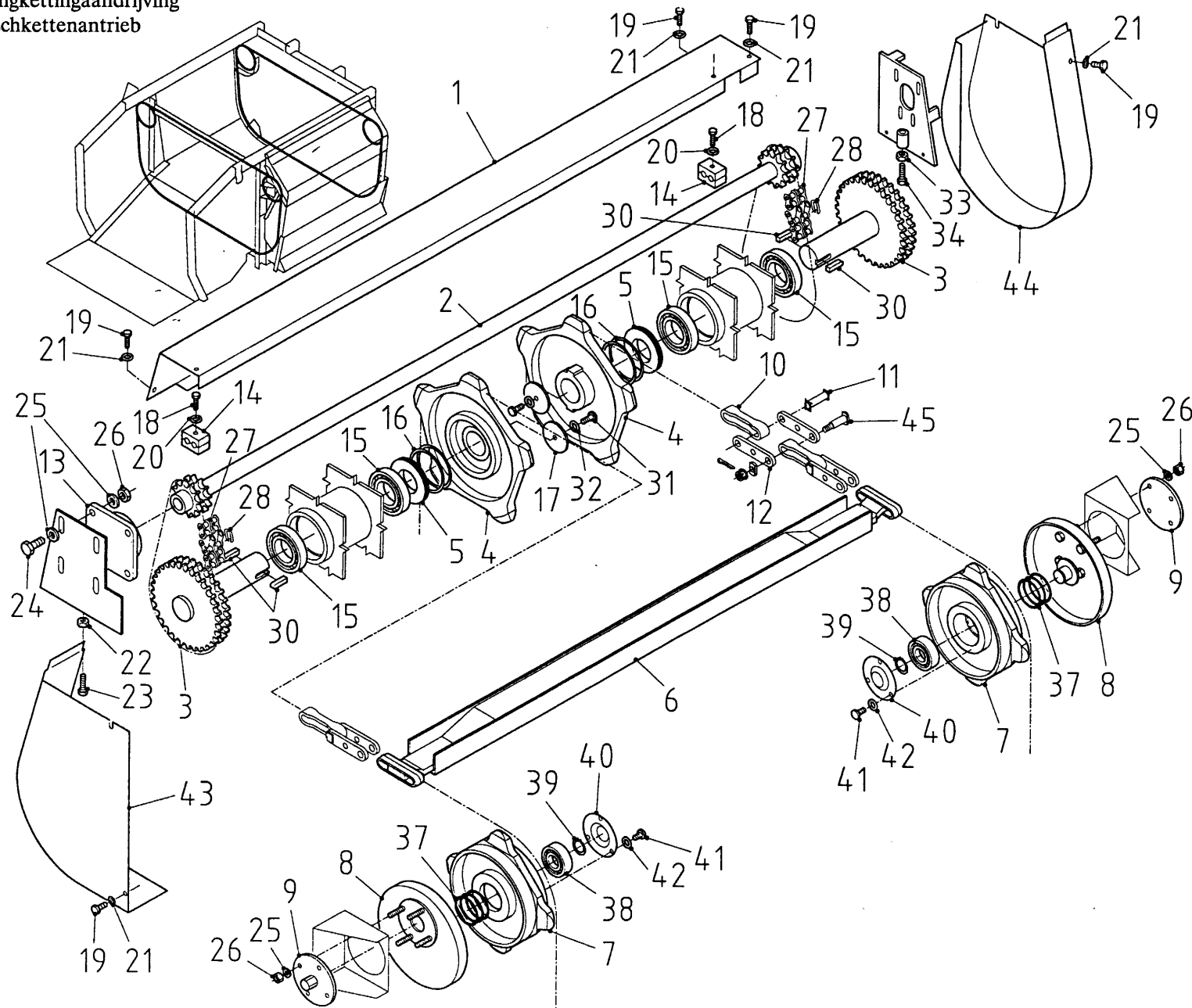

bestelnummer	ordernummer	num.à commander	Bestellnummer
40	22607	2	
41	80612	6	M 6 x 12
42	85106	6	M 6
43	11337	1	
44	11340	1	
45	39106	2	

Afbeelding 5  
Aandrijving  
Antrieb

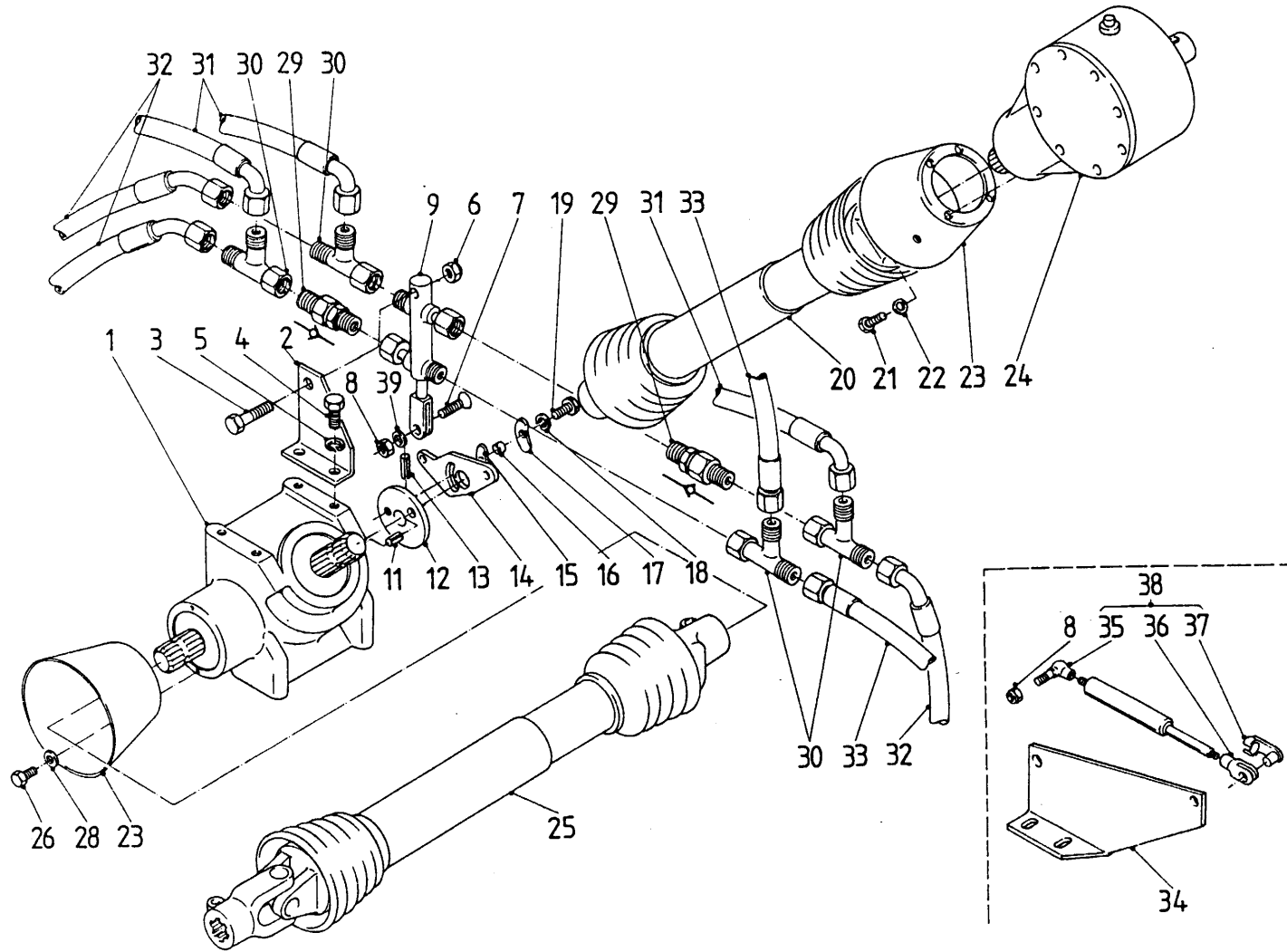

bestelnummer	ordernummer	num.à commander	Bestellnummer
1	90226	1	
2	<del>22964</del>	1	22965
3	81045	1	M 10 x 45
4	81225	2	M 12 x 25
5	85012	2	M 12
6	86210	1	M 10
7	84125	1	M 8 x 25
8	86208	1	M 8
9	51024	1	
11	88015	1	φ 8 x 16
12	31096	1	
13	88030	1	φ 6 x 30
14	<del>41291</del>	1	31095
15	60211	1	
16	31098	1	
17	22965	1	
18	85008	1	
19	80820	1	
20	90233	1	M 8
21	81016	2	M 8 x 20
22	85113	2	
23	90284	2	M 10 x 16
24	90227	1	M 10
25	90232	1	
26	80816	2	
28	85109	2	
29	X53018	2	M 8 x 16
30	X50300	4	M 8
31	W50719	3	
32	W50806	3	
33	W50807	2	¼" L= 900 RH
34	23656	1	¼" L=950 R45°
35	70092	1	¼" L=1050 RR
36	31293	1	
37	90317	1	
38	90316	1	
39	85108	1	M 8

**Afbeelding 6**  
**Tandwielkasten**  
**Getriebe**

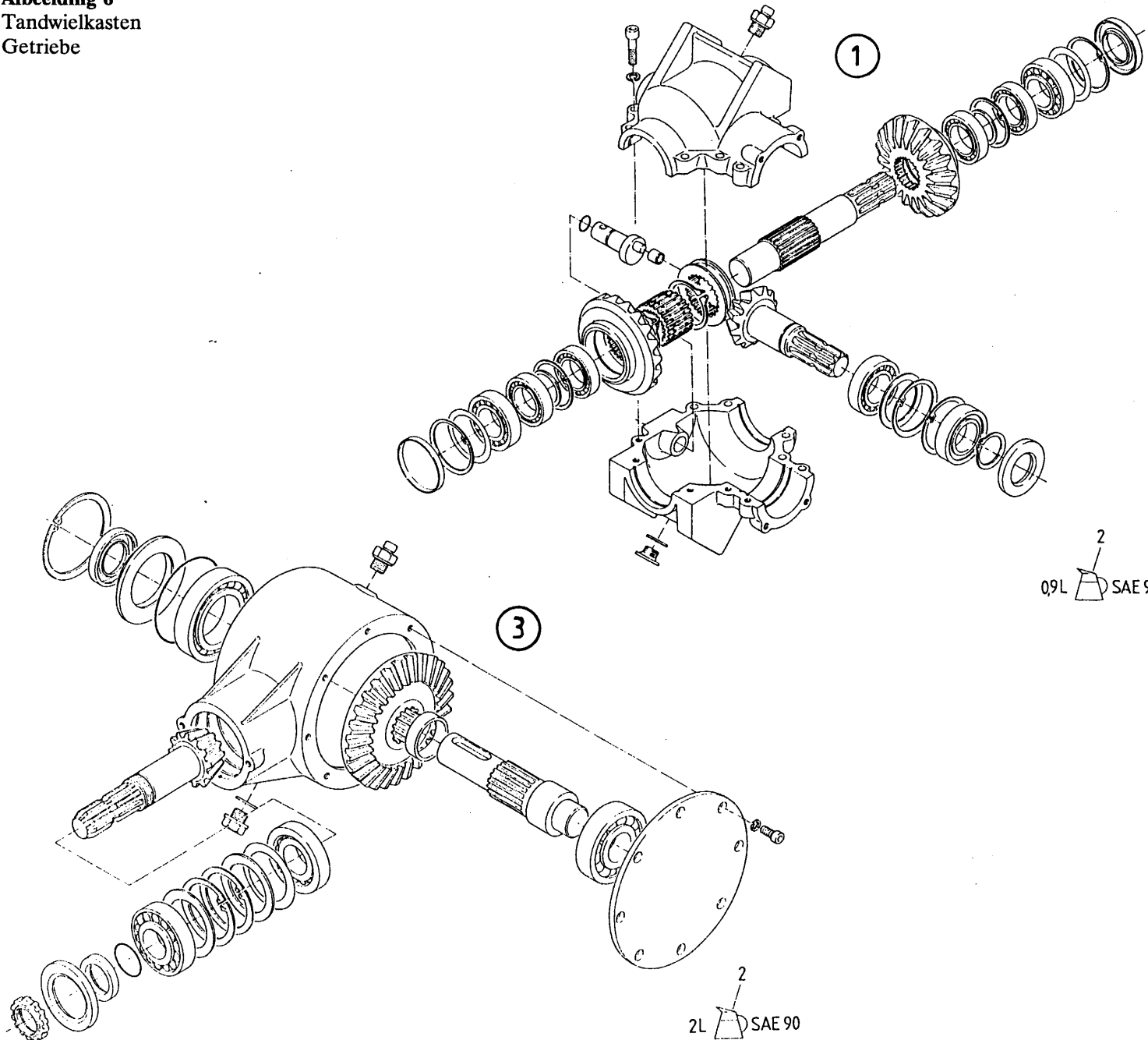

bestelnummerordernummer  
 num.à commander  
 Bestellnummer

1	90226	1
2	90307	0,9L
3	90227	1
2	90307	2L

**Afbeelding 7**  
Teleskoop  
Teleskoparm

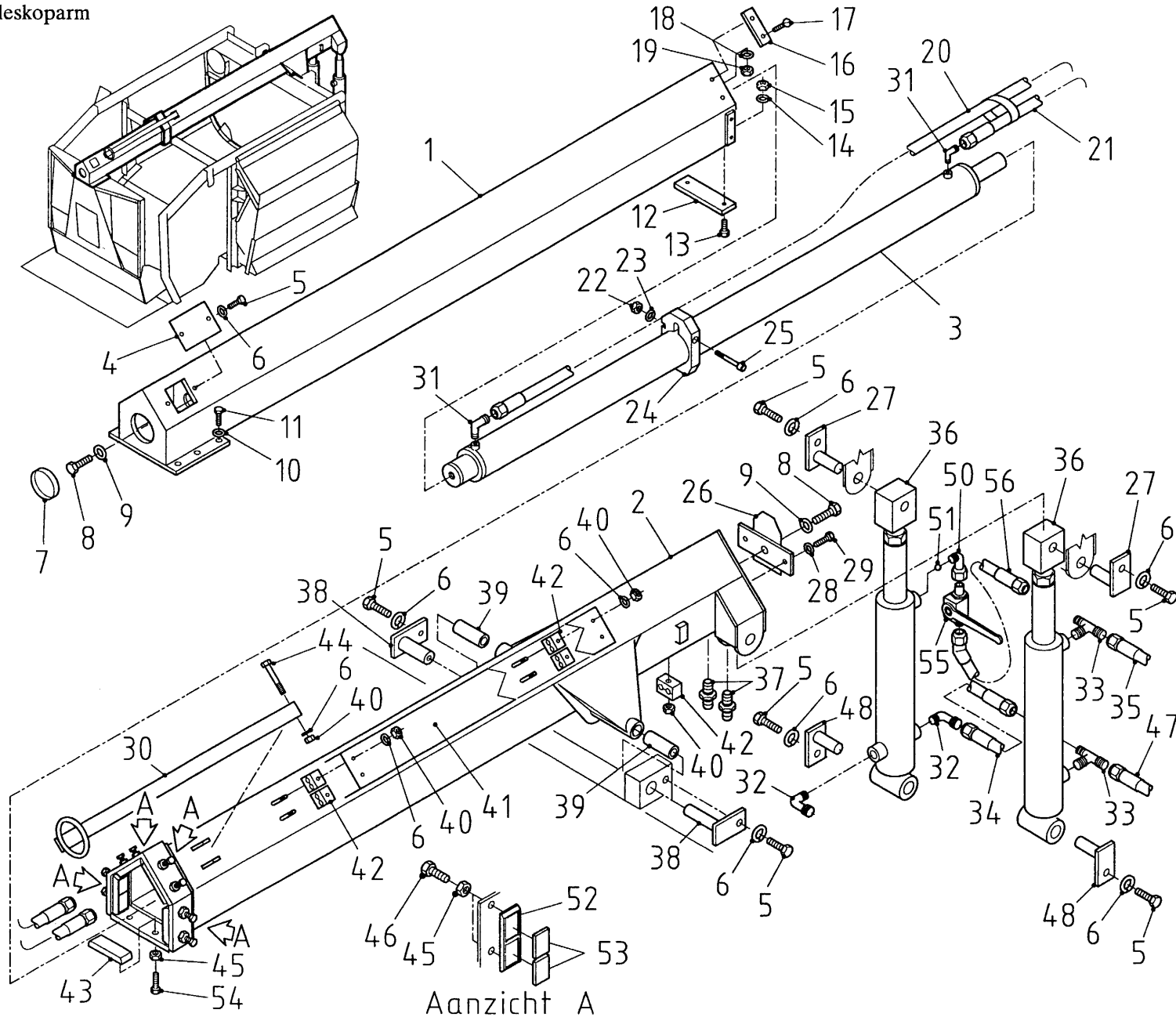

bestelnummer  
ordernummer  
num.à commander  
Bestellnummer

1	11211	1
2	11210	1
3	51005	1
4	22907	1
5	80816	8 M 8 x 16
6	85008	9 M 8
7	60202	1
8	81860	2 M 18 x 60
9	85018	2 M 18
10	85020	6
11	84435	6 M 20 x 45
12	60203	1
13	84102	2 M 10 x 30
14	85110	2 M 10
15	86210	2 M 10
16	22904	4
17	84123	8 M 6 x 20
18	85106	8 M 6
19	86206	8 M 6
20	W50784	1 ½" L=2200
21	W50783	1 ½" L=700
22	86210	1 M 10
23	85110	1 M 10
24	60205	1
25	84434	1 M 10 x 100
26	11214	1
27	11223	2
28	85116	2 M 16
29	81641	2 M 16 x 40
30	11213	1
31	X50101	2
32	X50103	1
33	X50356	2
34	W50792	1 ⅜ L=300
35	W50790	1 ⅜ L=4500
36	51007	2
37	X50500	
38	11226	2
39	51760	2

Afbeelding 7  
Telescoop  
Teleskoparm

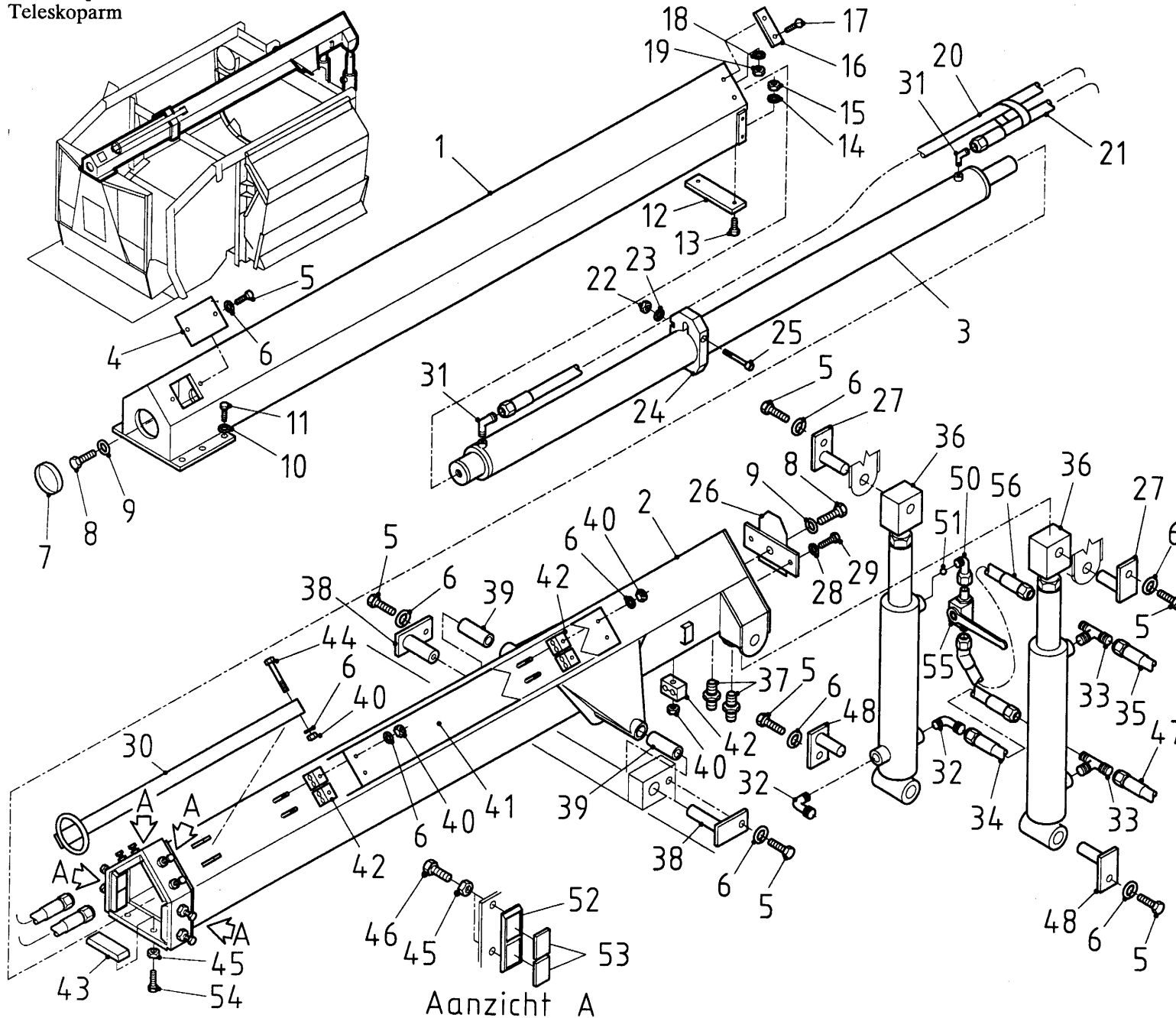

bestelnummer	ordernummer	num.à commander	Bestellnummer
40	86208	5	M 8
41	40299	1	
42	90159	5	
43A	60204	1	→ 01
43B	60221	1	↳ 02
44	80880	1	M 8 x 80
45	86116	8	M 16
46	81661	8	M 16 x 60
47	W50808	1	3/8" L=5200
48	11224	2	
49	80845	1	M 8 x 45
50	X50146	1	
51	70096	1	
52	21888	4	
53	60145	8	
54	81671	2	M 16 X 70
55	51023	1	
56	W50810	1	3/8" L=400

**Afbeelding 8**  
**Snijsysteem**  
**Schneidvorrichtung**

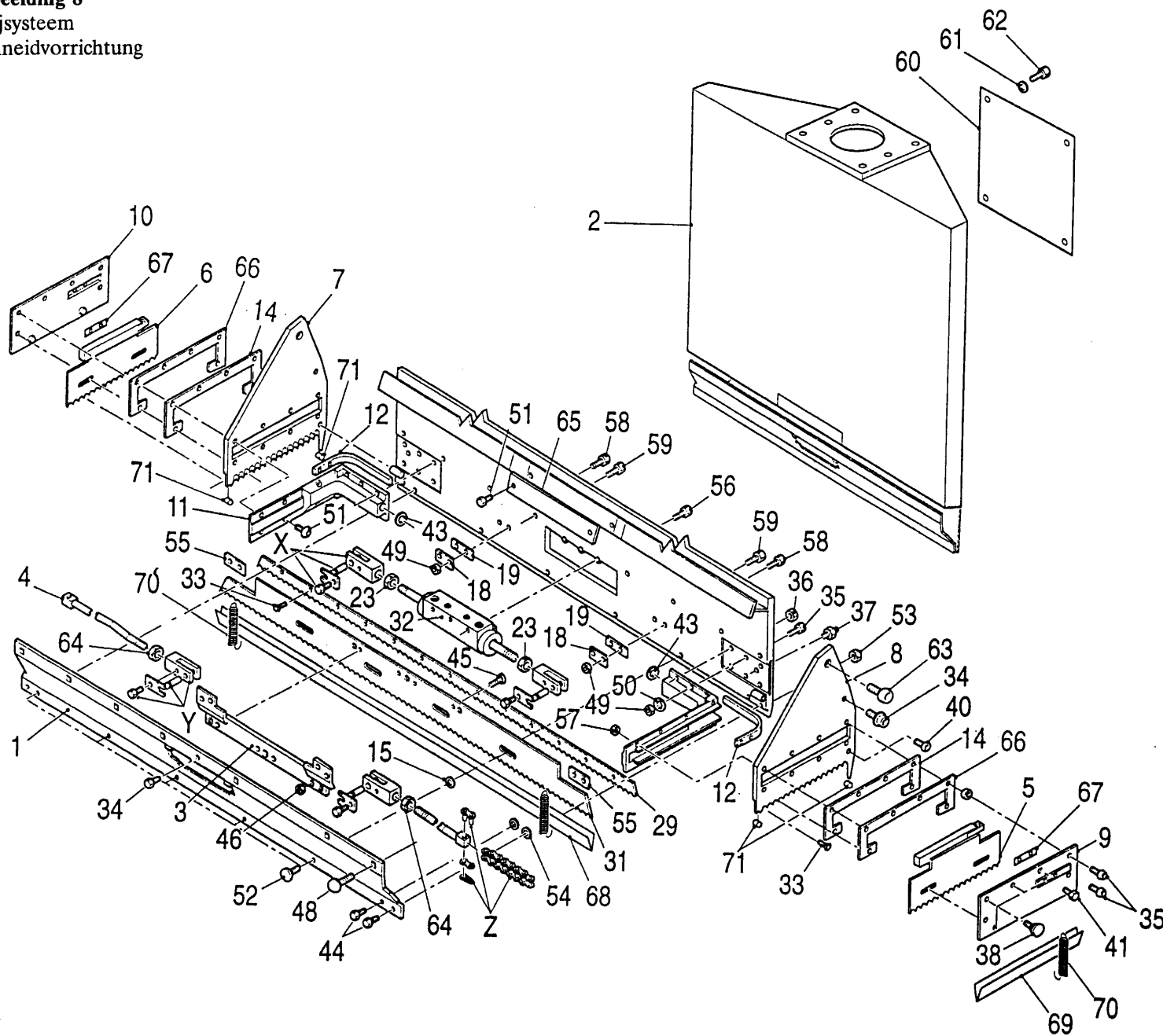

bestelnummer	ordernummer	num.à commander	Bestellnummer
1	22683	1	
2	11228	1	
3	11351	1	
4	11145	2	
5	11348	1	LINKS
6	11347	1	RECHTS
7	11231	1	
8	11230	1	
9	11144	1	
10	11143	1	
11	30851	2	
12	22289	2	
14	22323	2	
15	31005	4	
18	22284	2	
19	23644	2	
23	86113	2	M 14 x 1,5
29	23280	1	
31	23278	1	
32	50099	1	
33	85218	15	φ 5 x 16
34	83915	3	M 10 x 30
35	83930	16	M 8 x 30
36	86512	8	M 12
37	89503	2	M 6
38	83831	8	M 8 x 25
40	84102	2	M 10 x 30
41	83912	4	M 6 x 12
43	52026	2	
44	83922	4	M 10 x 20
45	84109	4	M 6 x 16
46	86506	4	M 6
48	83923	8	M 12 x 20

**Afbeelding 8**  
**Snijsysteem**  
**Schneidvorrichtung**

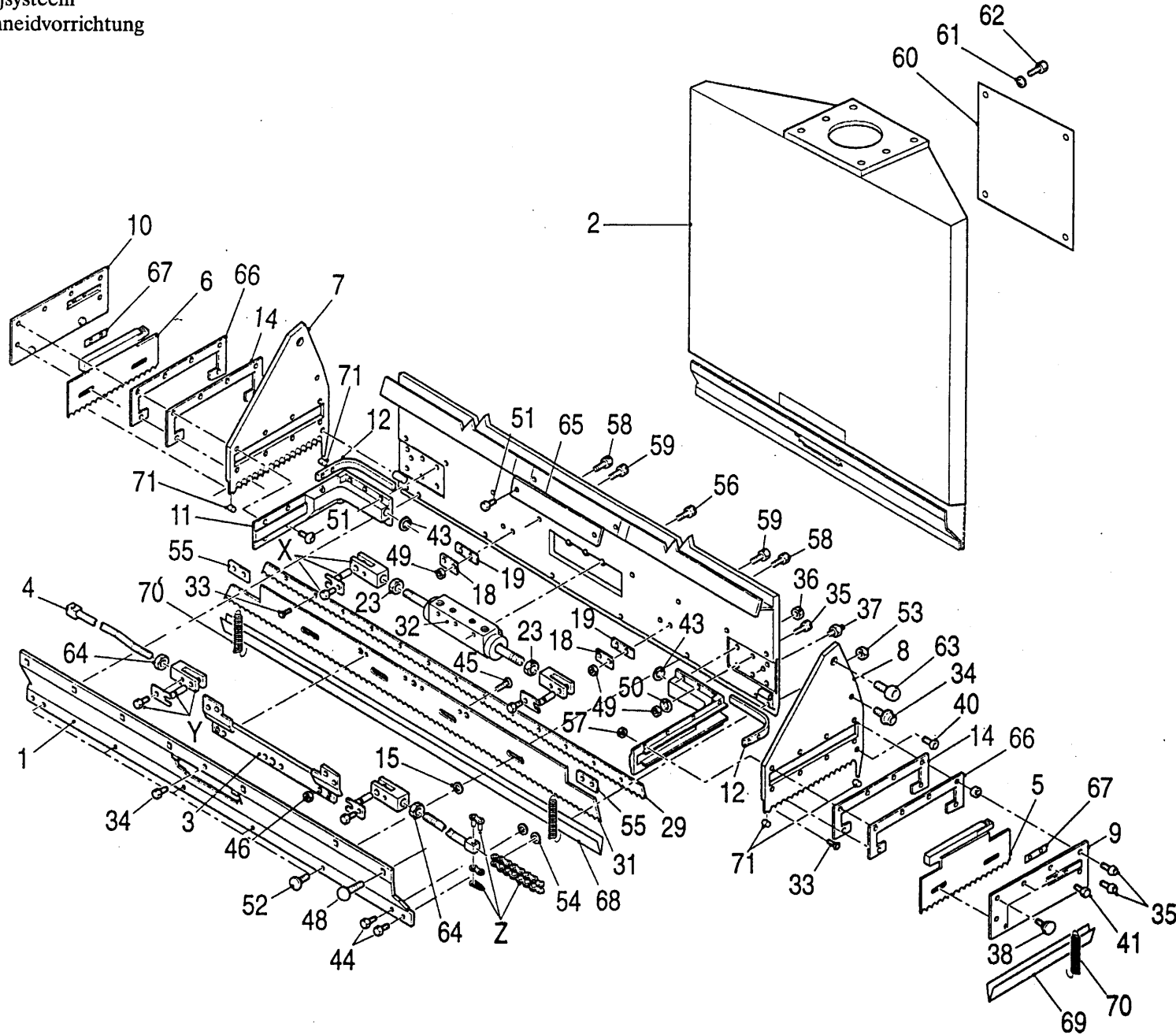

bestelnummer	ordernummer	num.à commander	Bestellnummer
49	86508	16	M 8
50	85608	12	M 8
51	83913	4	M 8 x 12
52	84901	4	M 10 x 20
53	86810	8	M 10
54	85228	4	
55	22682	2	
56	83915	3	M 10 x 30
57	86808	8	M 8
58	84814	2	M 8 x 40
59	84810	2	M 8 x 30
60	40307	1	
61	85008	6	M 8
62	80812	6	M 8 x 12
63	83931	2	M 16 x 30
64	86112	2	
65	22943	1	
66	23274	2	
67	23275	2	
68	40316	1	
69	40325	2	
70	65019	4	
71	22926	2	
X	05024	2	
Y	05196	2	
Z	05197	2	

**Afbeelding 9**  
**Snijbordkomponenten**  
**Teile der Schneidplatte**

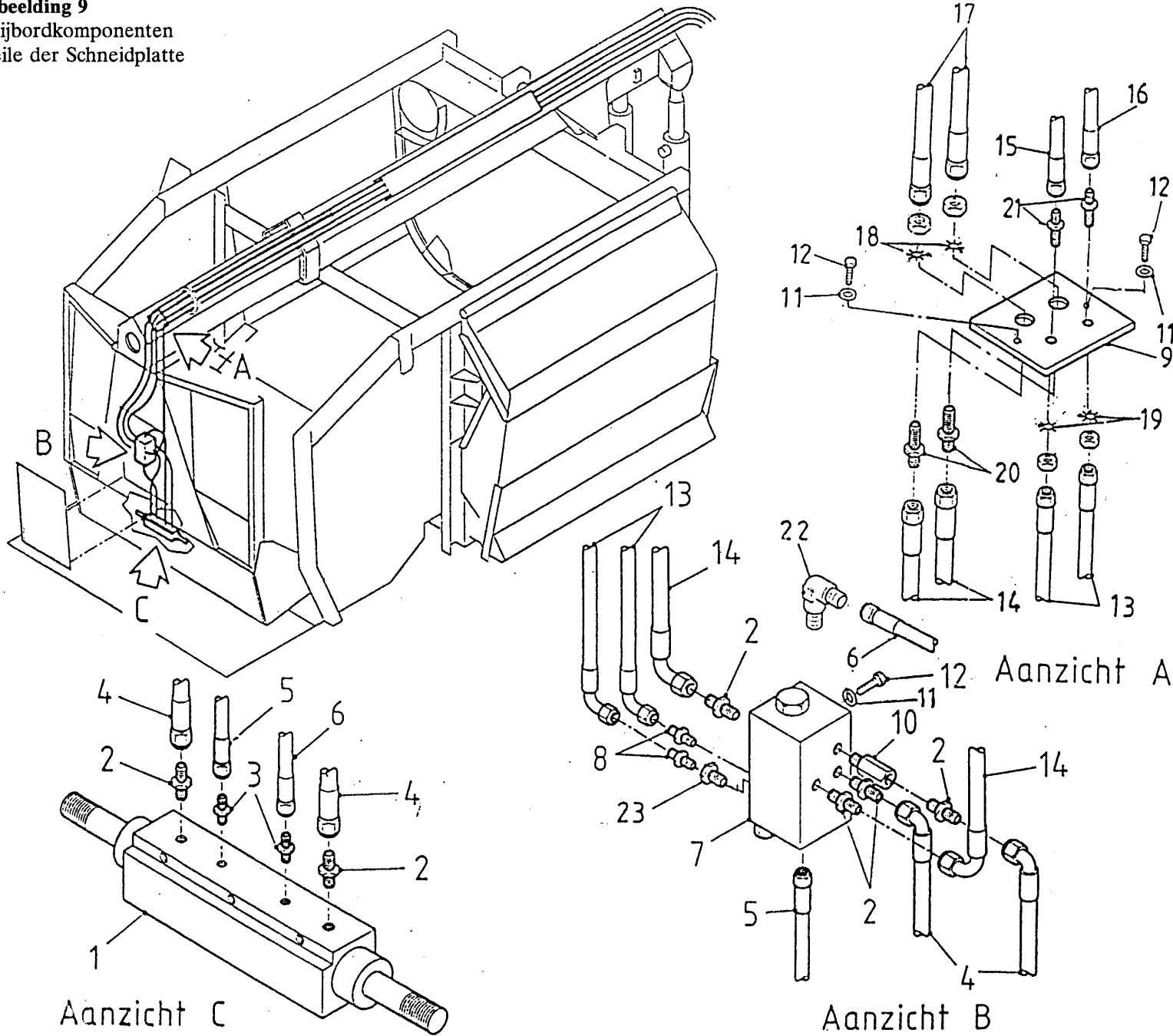

bestelnummer	ordernummer	num.à commander	Bestellnummer
1	50099	1	
2	X50102	6	
3	X50104	2	
4	W50688	2	½ L=600
5	W50742	1	¼ L=550
6	W50607	1	¼ L=1000
7	53055	1	
8	X50141	2	
9	22907	1	
10	53138	1	
11	85008	4	M 8
12	80816	4	M 8 x 16
13	W50802	2	¾ L=750
14	W50801	2	½ L=700
15	W50808	1	¾ L=5200
16	W50790	1	¾ L=4500
17	W50789	2	½ L=5150
18	85230	2	
19	85219	2	
20	X50500	2	
21	X50502	2	
22	X50147	1	
23	31250	1	φ 1,5 mm



**Afbeelding 10**  
**Mescilinder**  
**Messerzylinder**

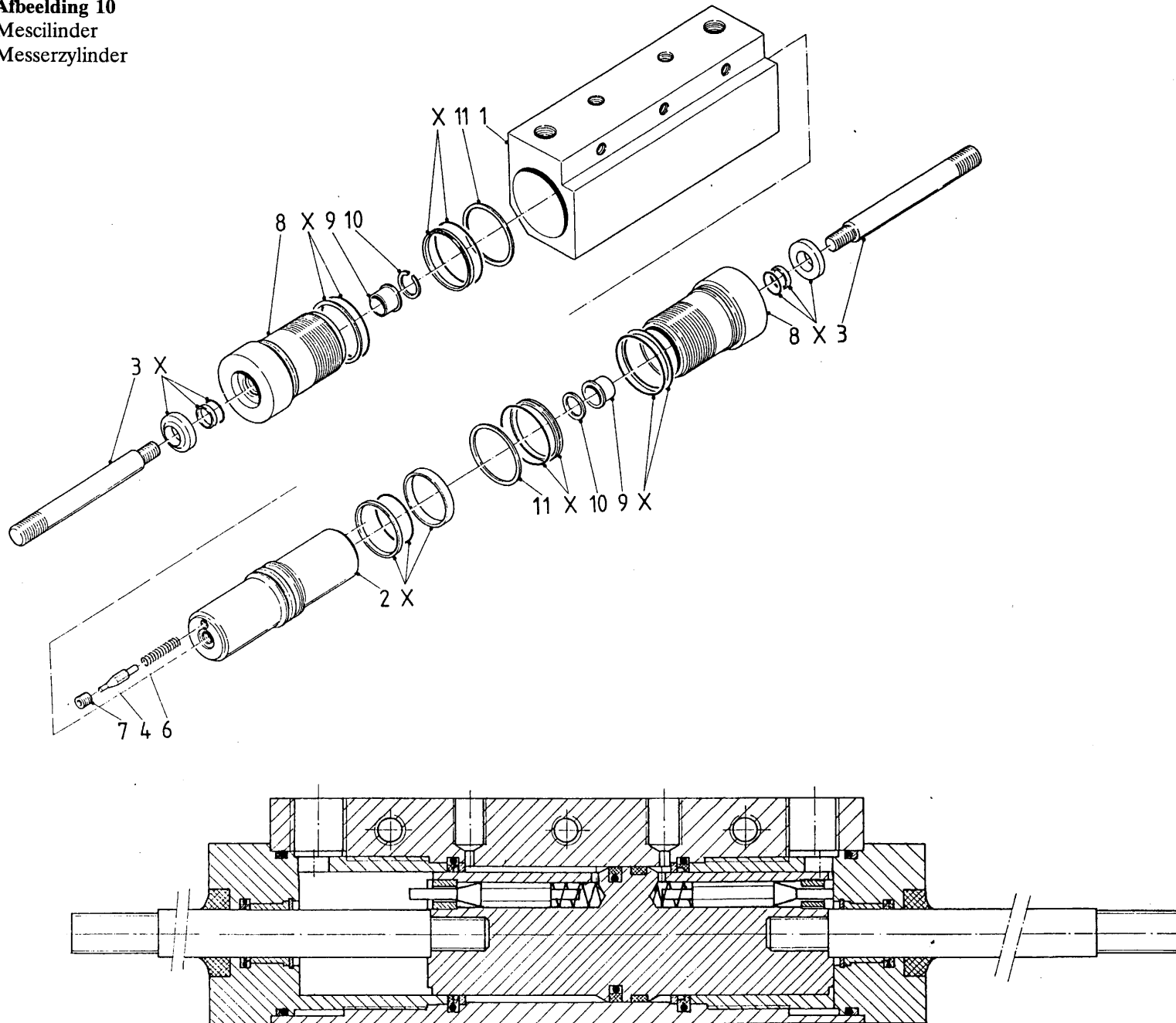

bestelnummer  
 ordernummer  
 num.à commander  
 Bestellnummer

	50099	
1	30869	3
2	30866	1
3	30867	2
4	30933	2
6	65055	2
7	30870	2
8	30863	3
9	30864	2
10	87312	2
11	30868	2
X	05188	1

Afbeelding 11  
 Stuurventielblok  
 Ventilblok

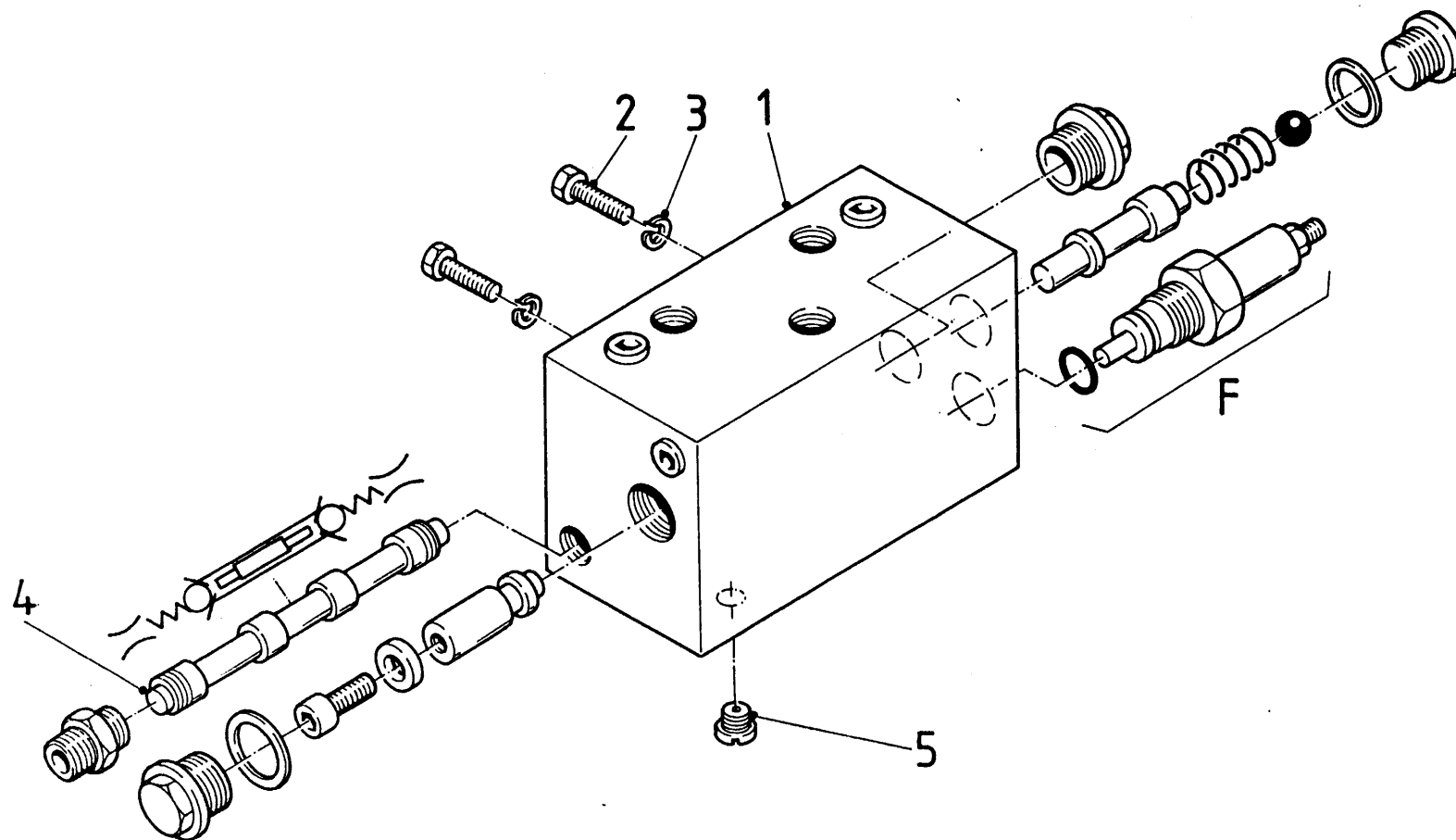

bestelnummer  
 ordernummer  
 num.à commander  
 Bestelnummer

1	53138	1	
2	80816	2	M 8 x 16
3	85008	2	M 8
4	53150	1	
5	31250	1	
F	05198	1	

**Afbeelding 12**  
 Mechanische afstandsbediening  
 Mechanische Fernbedienung

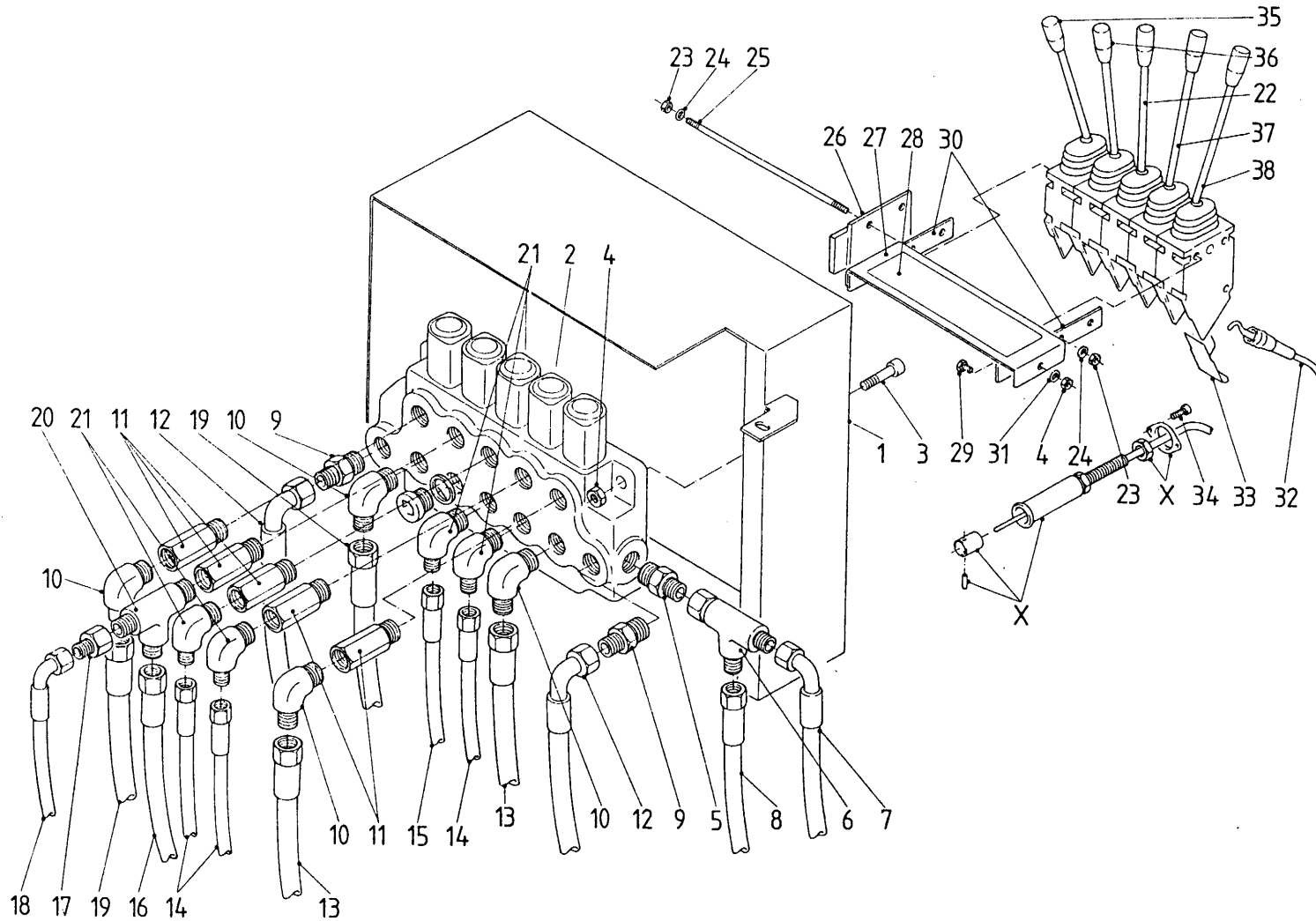

bestelnummer	ordernummer	num.à commander	Bestellnummer
1	22056	1	
2	53137	1	
3	84419	3	M 8 x 45
4	86208	5	M 8
5	50141	1	
6	X50309	1	
7	W50785	1	3/8 L = 4500
8	W50796	1	3/8 L = 5050
9	X50102	2	
10	X50101	4	
11	50133	5	
12	W50778	2	1/2 L = 3000
13	W50793	2	1/2 L = 2100
14	W50719	3	1/4 L = 900 RH
15	W50807	1	1/4 L = 1050 RR
16	W50794	1	3/8 L = 1000
17	X50168	1	
18	W50787	1	1/4 L = 600
19	W50789	2	1/2 L = 5150
20	X50302	1	
21	X50118	4	
22	53099	1	
23	86206	6	M 6
24	85106	6	M 6
25	84159	3	M 6
26	11139	1	
27	22245	1	
28	91112	1	
29	80816	2	M 8 x 16
30	22244	2	
31	85108	2	M 8
32	79060	5	L = 3000
33	60210	5	
34	84426	10	M 6 x 16
35	53128	1	30° R
36	53127	1	15° R
37	53129	1	15° L
38	53130	1	30° L
X	05207	5	

**Afbeelding 13**  
 Elektrische bediening  
 Elektrische Bedienung

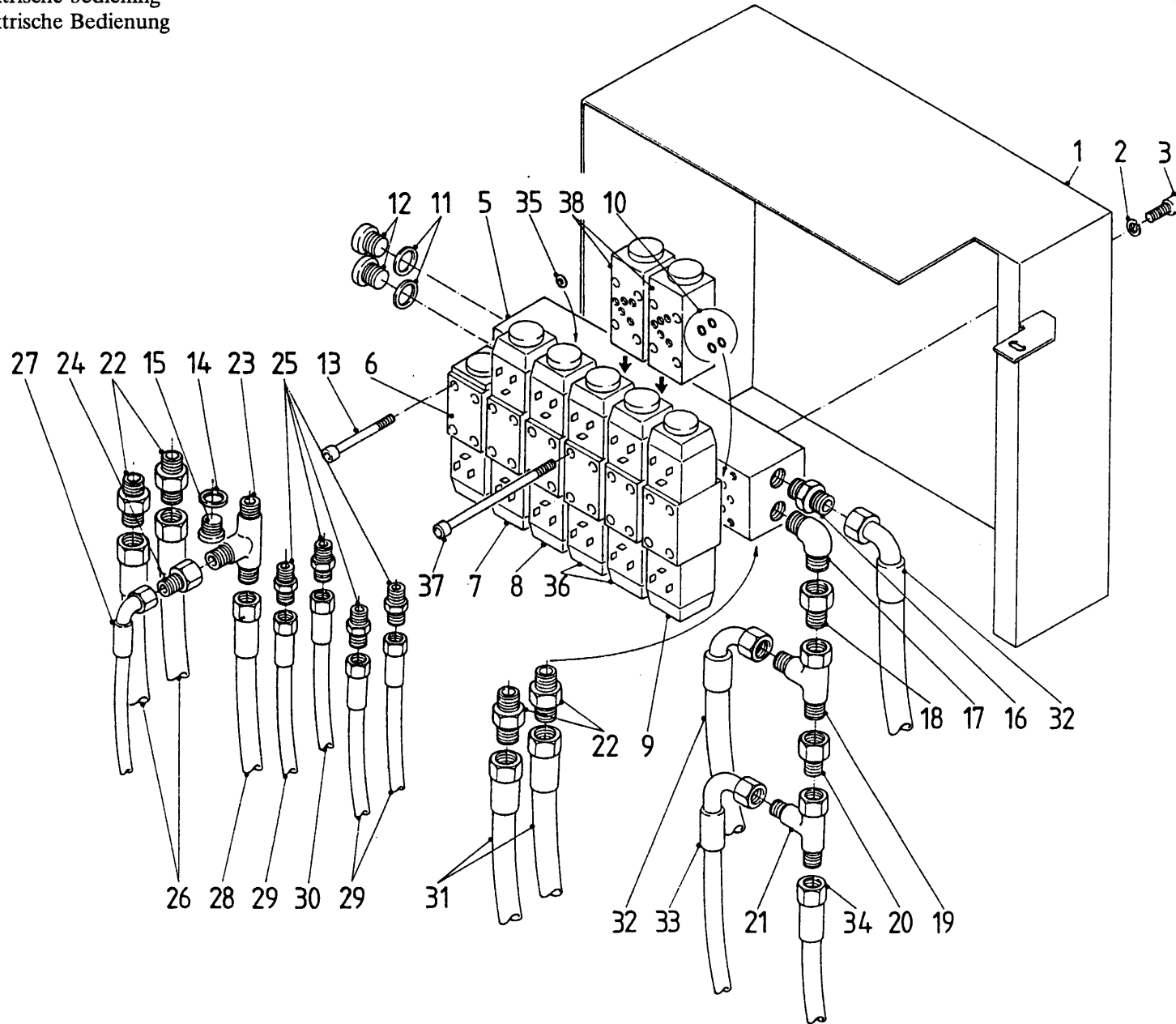

bestelnummer	ordernummer	num.à commander	Bestellnummer
1	22056	1	
2	85008	4	M 8
3	84420	4	M 8 x 16
5	53067	1	
6	53080	1	
7	53105	1	
8	53078	1	
9	53104	1	
10	78057	24	
11	85225	2	
12	53116	2	
13	84433	16	M 5 x 30
14	85215	1	
15	53319	1	
16	X50142	1	
17	X50140	1	
18	50169	1	
19	X50303	1	
20	50154	1	
21	X50309	1	
22	X50102	4	
23	X50302	1	
24	X50168	1	
25	X50114	4	
26	W50789	2	½" 5150 RR
27	W50787	1	¼" 600 RH
28	W50794	1	⅜" 1000 R 45°
29	W50719	3	¼" 900 RH
30	W50807	1	¼" 1050 RR
31	W50793	2	½" 2100 RR
32	W50768	2	½" 3000 RH
33	W50785	1	⅜" 4500 RH
34	W50796	1	⅜" 5050 RR
35	31214	1	φ 2,6 mm
36	53135	2	
37	84438	8	M 5 X 70
38	53149	2	

**Afbeelding 14**  
 Bedieningskast en aansluitschema  
 Bedienungspult und Schaltplan

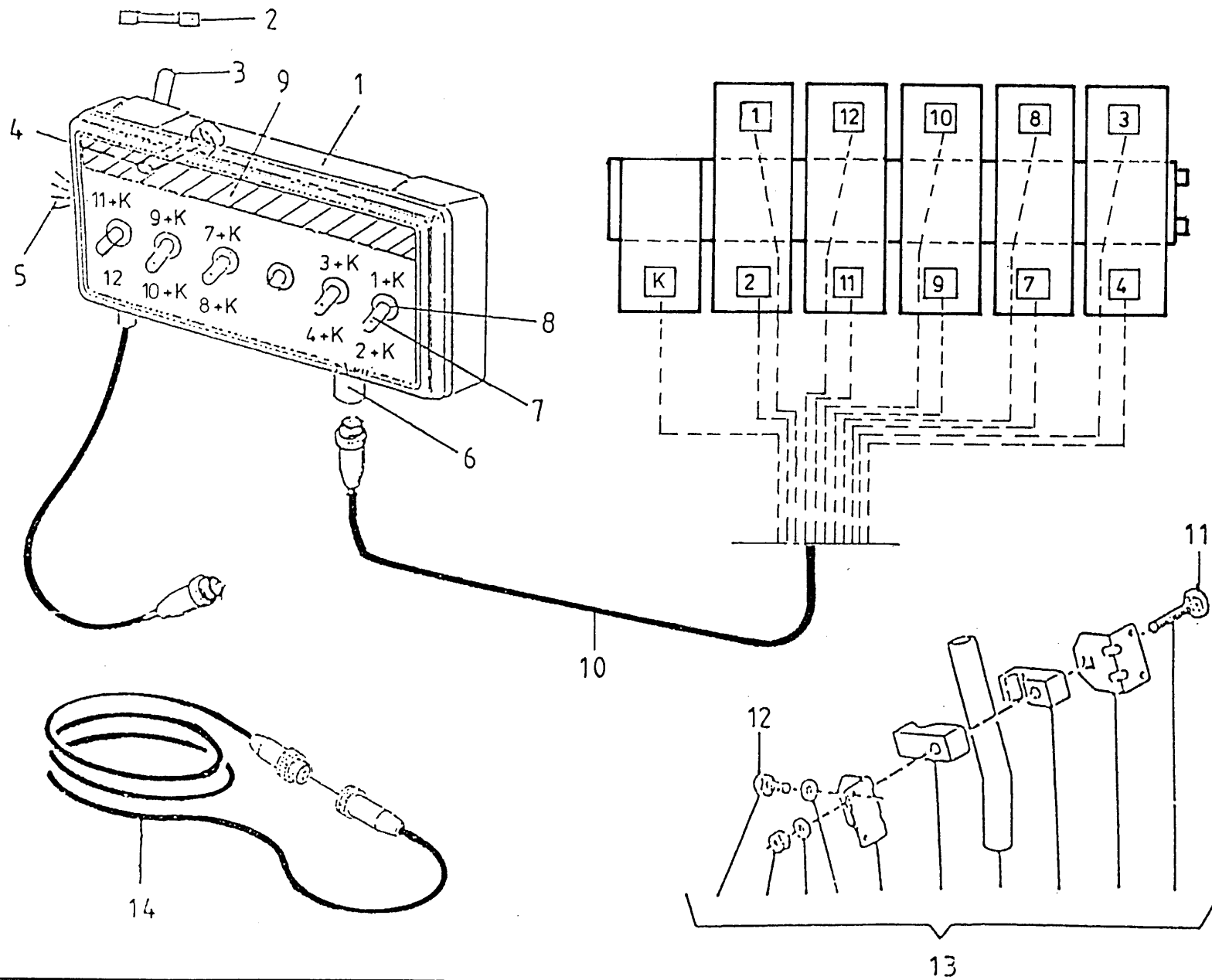

bestelnummer  
 ordernummer  
 num.à commander  
 Bestellnummer

1	98073	1
2	98053	1
3	98054	1
4	98052	1
5	98051	1
6	98058	1
7	98056	5
8	98055	5
9	91015	1
10	98069	1
11	83150	1
12	84305	1
13	05154	1
14	98065	1

**Afbeelding 15**  
 Schakelcilinder en zijklepcilinder  
 Schaltzylinder und Seitenklappezylinder

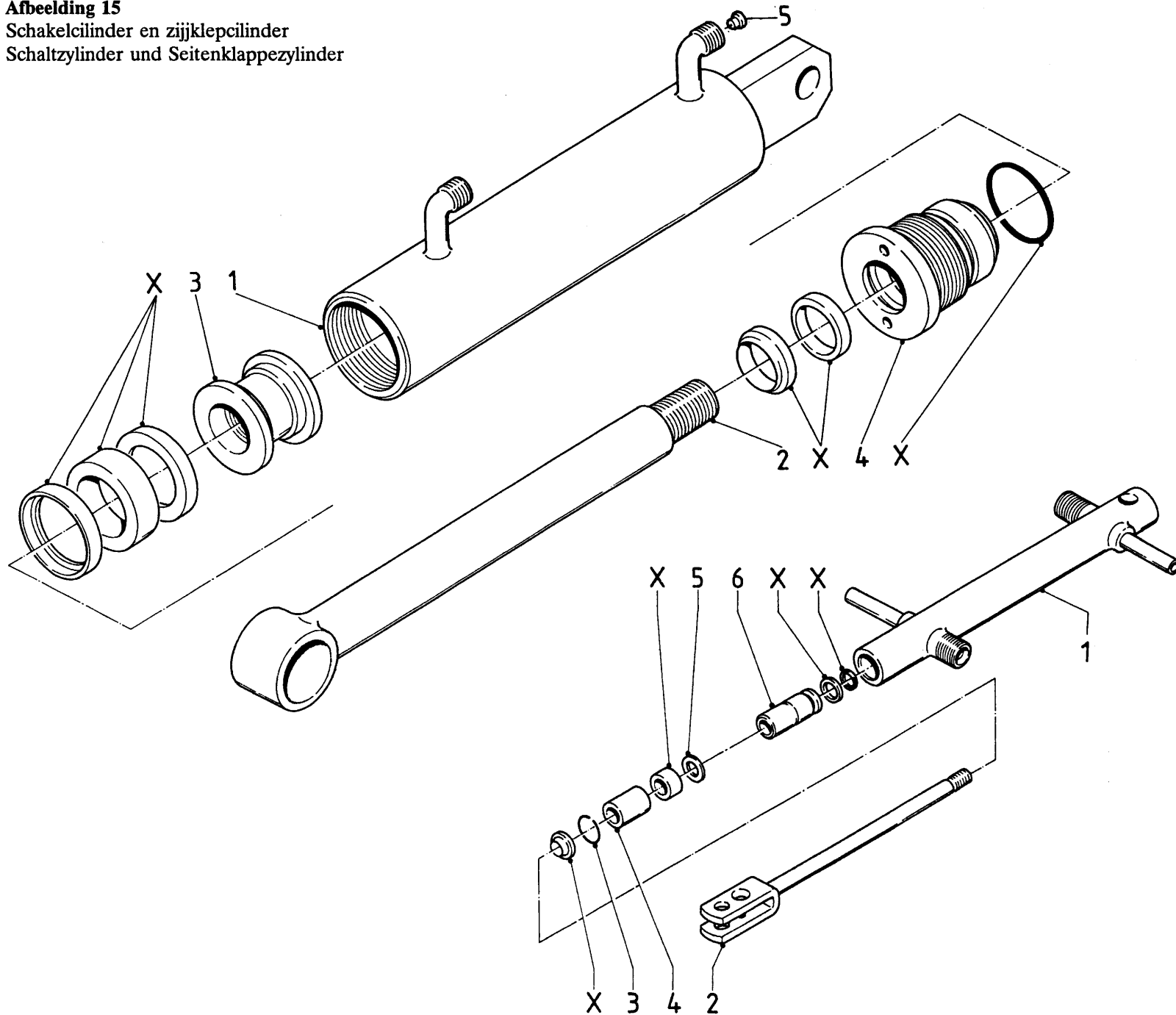

bestelnummer  
 ordernummer  
 num.à commander  
 Bestellnummer

	<b>50100</b>		
1	10969	1	
2	11132	1	
3	30860	1	
4	30859	1	
5	30726	1	
X	05206	1	
	<b>51024</b>		
1A	11410	1	→01 (51012)
1B	11245	1	→02
2	11246	1	
3	85803	1	
4	31099	1	
5	31100	1	
6	31101	1	
X	05218	1	

**Afbeelding 16**  
 Cilinders teleskoop  
 Zylinder Teleskop

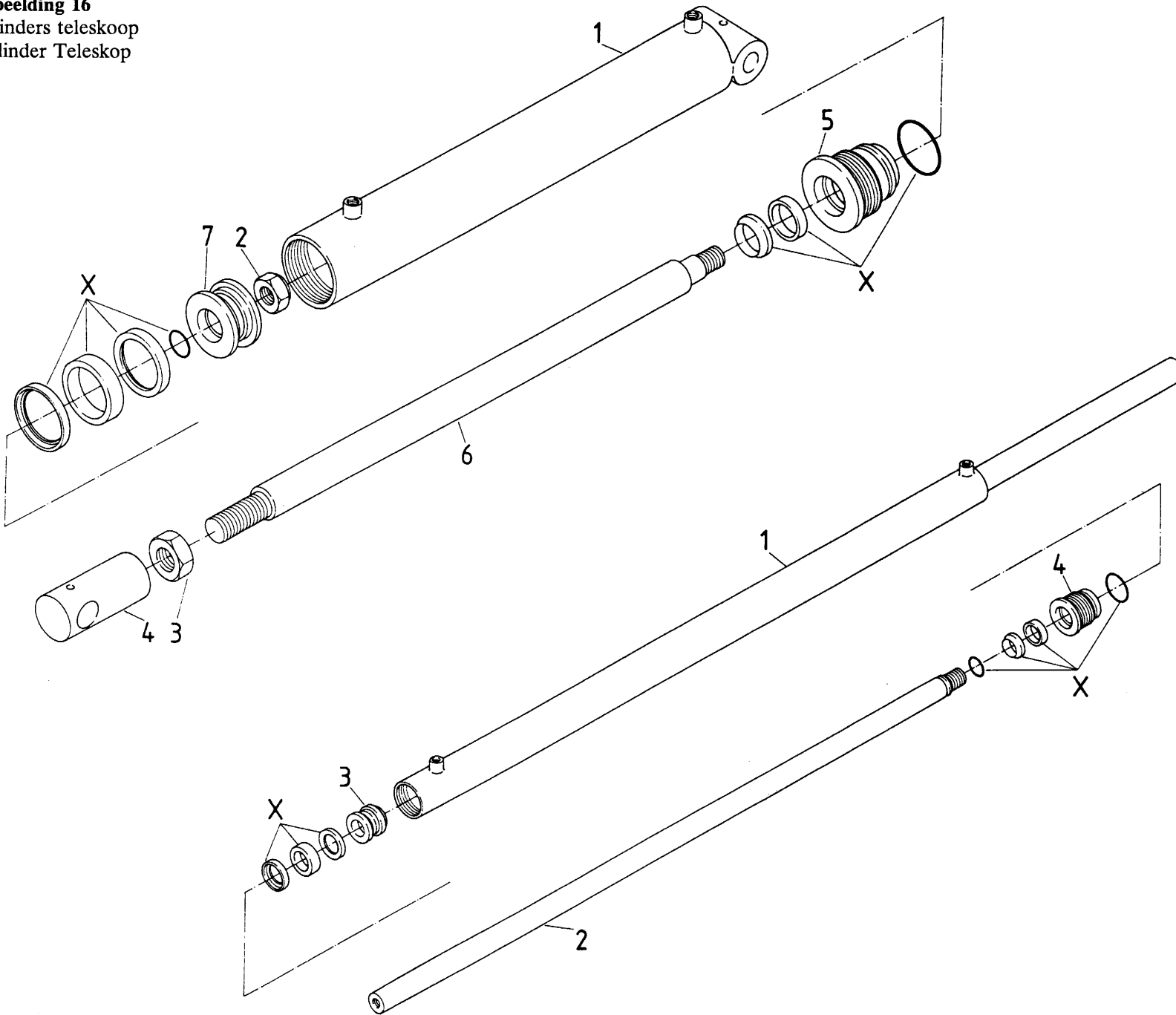

bestelnummer  
 ordernummer  
 num.à commander  
 Bestellnummer

	<b>51007</b>	
1	11218	1
2	86227	1
3	86920	1
4	31001	1
5	31085	1
6	31086	1
7	30911	1
X	05209	1

	<b>51005</b>	
1	11216	1
2	31076	1
3	31077	1
4	31078	1
X	05210	1

**Afbeelding 17**

Dissel en wielarmcilinder  
Deichsel- en Radarmcilinder

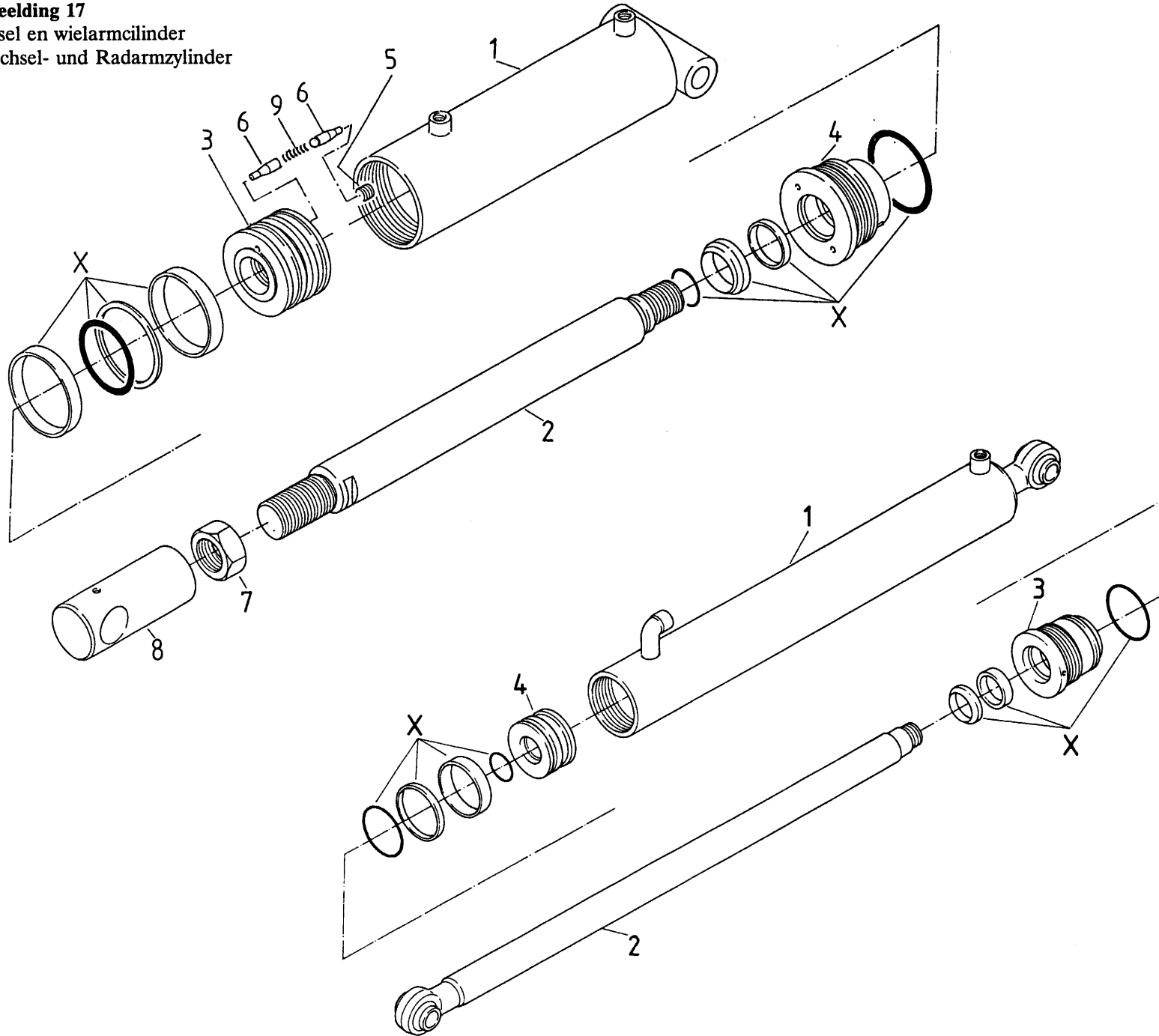

bestelnummer  
ordernummer  
num.à commander  
Bestellnummer

51006		
1	11217	1
2	31094	1
3	31082	1
4	31083	1
5	30870	1
6	31277	2
7	86920	1
8	31001	1
9	65029	1
X	05212	1

51002		
1	11171	1
2	11172	1
3	30520	1
4	31043	1
X	05211	1



**Afbeelding 18**  
**Aftakassen**  
**Gelenkwellen**

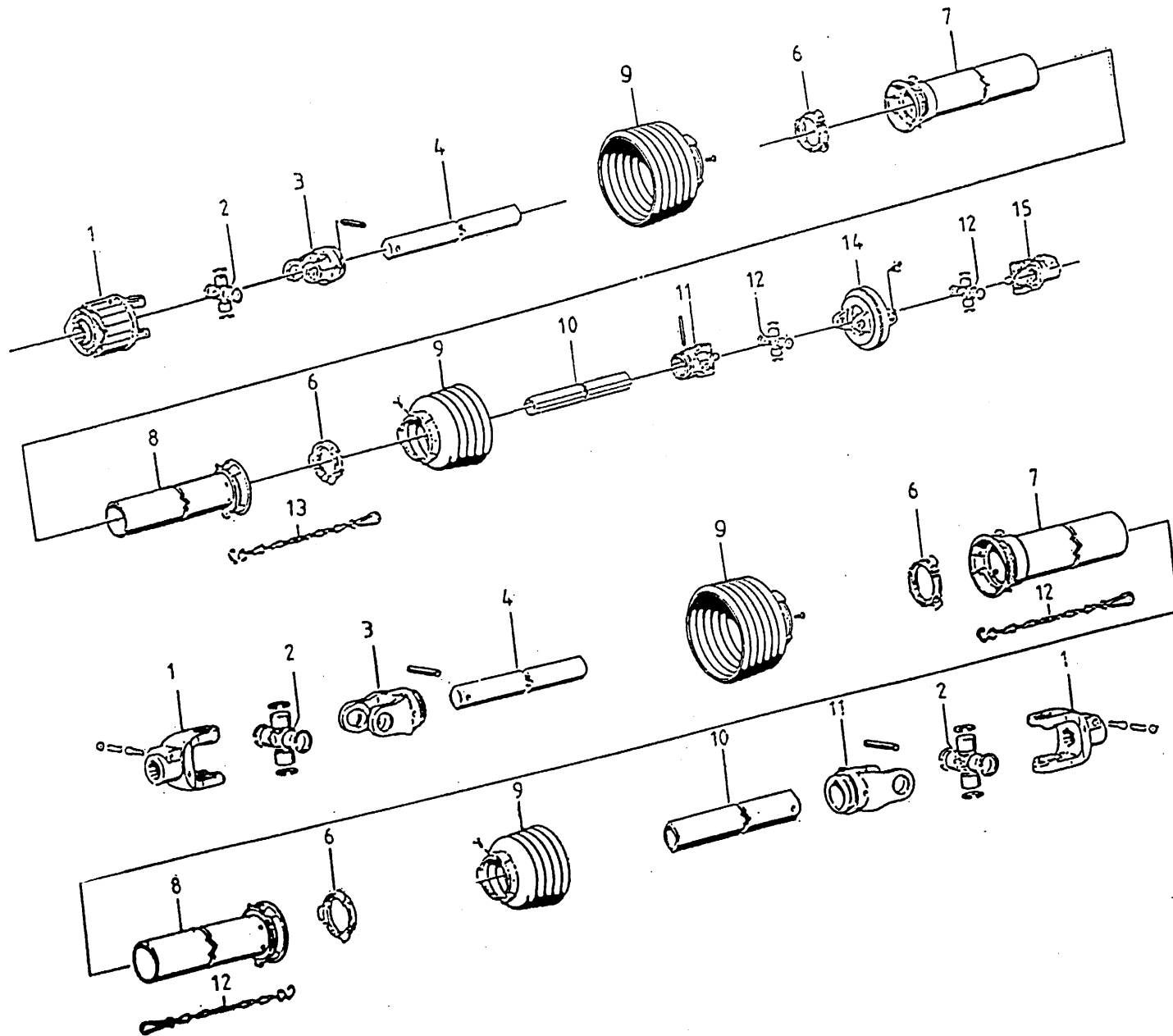

bestelnummer  
 ordernummer  
 num.à commander  
 Bestellnummer

	<b>90232</b>	
1	90237	1
2	90249	1
3	90238	1
4	90239	1
6	90241	2
7	90242	1
8	90243	1
9	90245	2
10	90246	1
11	90251	2
12	90252	2
13	90266	2
14	90254	1
15	90272	1
	<b>90233</b>	
1	90255	2
2	90256	2
3	90257	1
4	90258	1
6	90260	2
7	90261	1
8	90262	1
9	90263	2
10	90264	1
11	90265	1
12	90266	2

**Afbeelding 19**  
 Elektronisch weegsysteem  
 Elektronische Waage

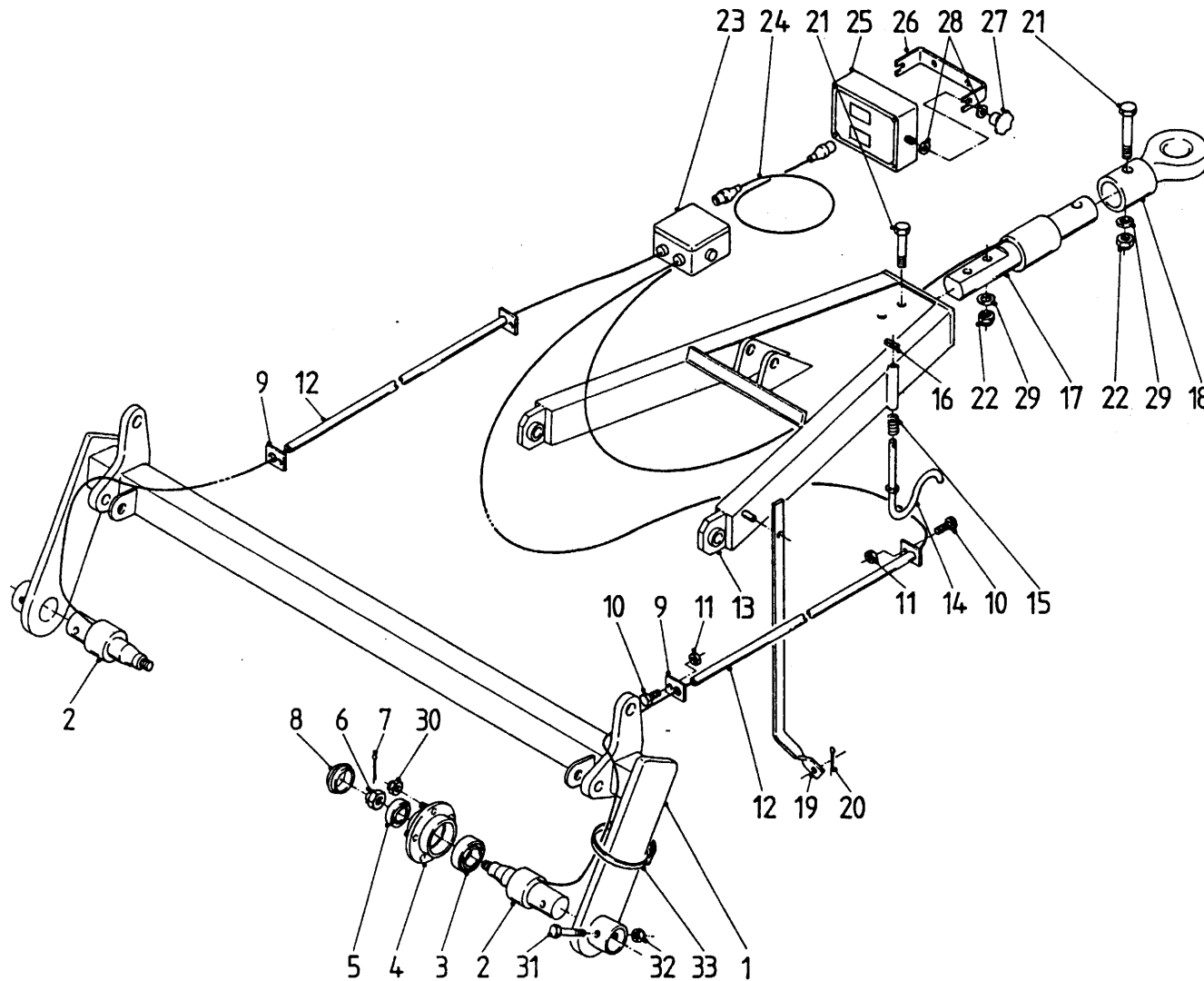

bestelnummer	ordernummer	num.à commander	Bestellnummer
1	11260	1	
2	90299	2	
3	70057	2	
4	90308	2	
5	70056	2	
6	90223	2	
7	90224	2	
8	90225	2	
9	23623	2	
10	80825	4	M 8 x 25
11	86208	4	M 8 N
12	11436	2	
13	11272	1	
14	11352	1	11439
15	65061	1	
16	88020	1	Ø5 x 20
17	90276	1	
18	11355	1	
19	22953	1	
20	88242	1	Ø 5 mm
21	82010	3	M20x100 12.9 gegalv.
22	86220	3	M20 Nyloc 8.8.gegalv.
23	98075	1	
24	98076	1	L = 2,5
25	90300	1	
26	23633	1	
27	60024	2	
28	60022	4	
29	85120	3	M 20
30	86922	12	M 18
31	81610	2	M 16 x 100
32	86216	2	M 16
33	90109	10	

**Afbeelding 20**

Hydraulisch schema mechanische bediening

Hydraulischer Schaltplan mechanische Fernbediening

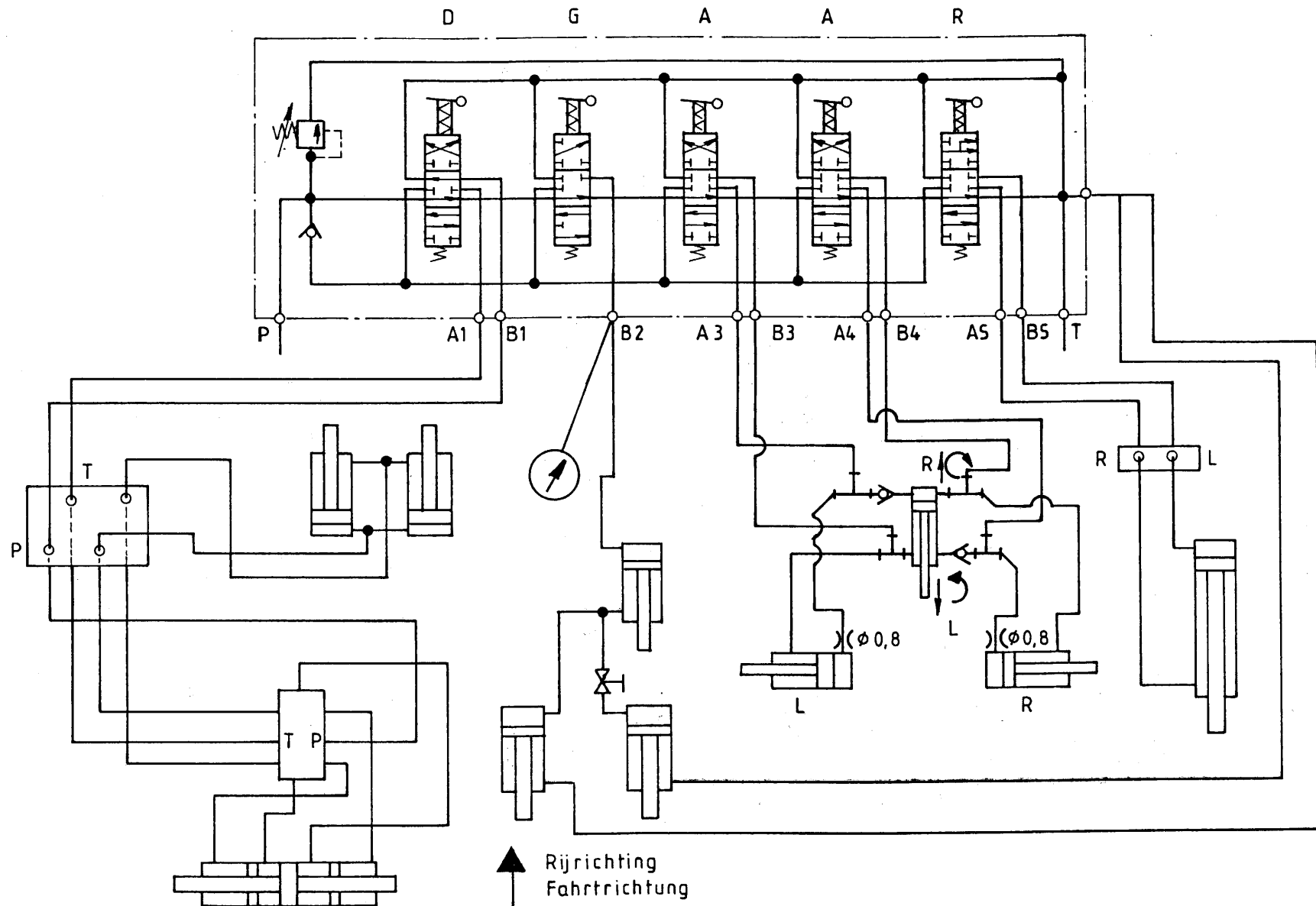

**Afbeelding 21**

Hydraulisch schema elektrische bediening

Hydraulischer Schaltplan elektrische Fernbediening

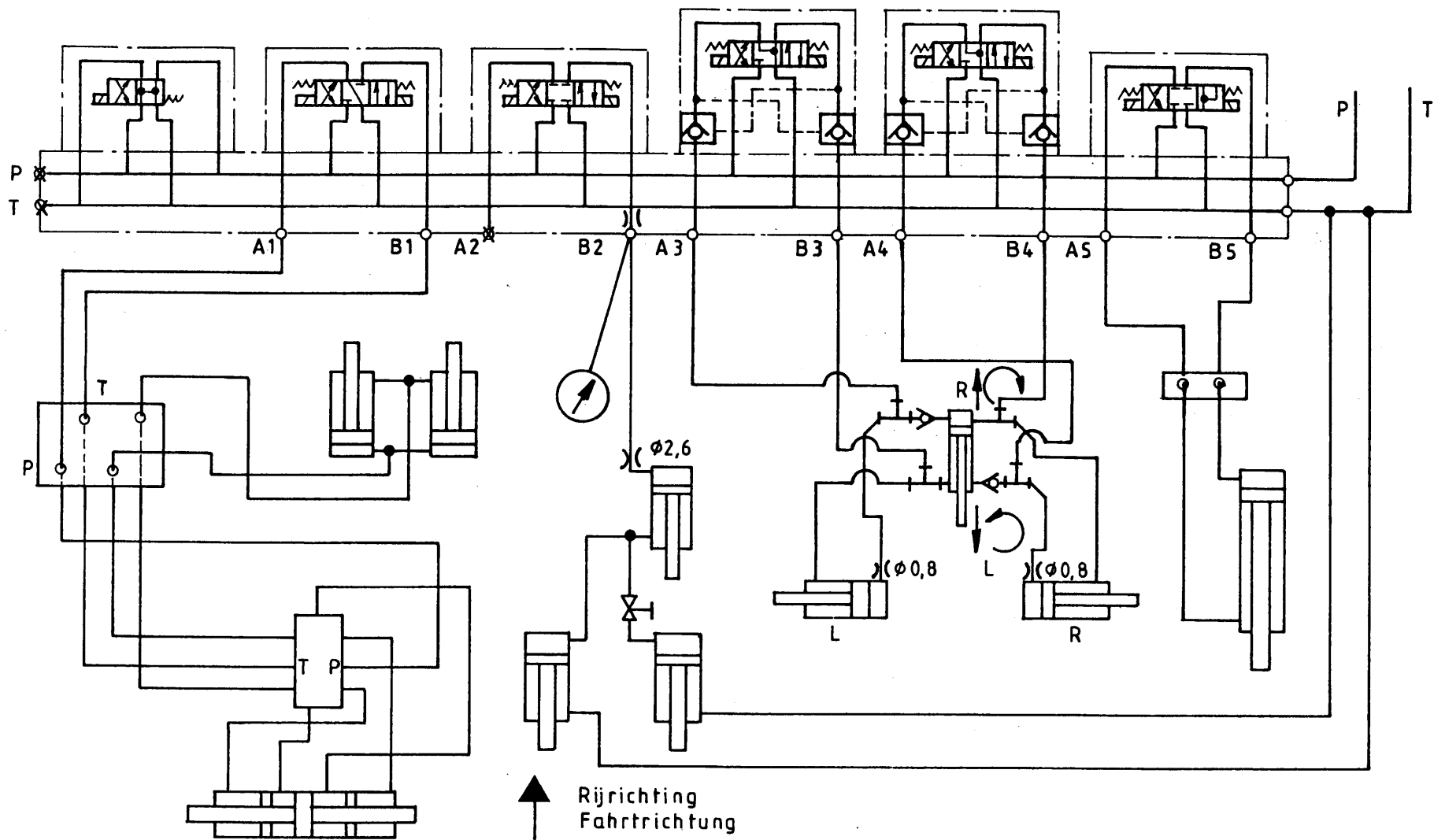

**Afbeelding 22**  
**Elektrisch schema**  
**Elektrischer Schaltplan**

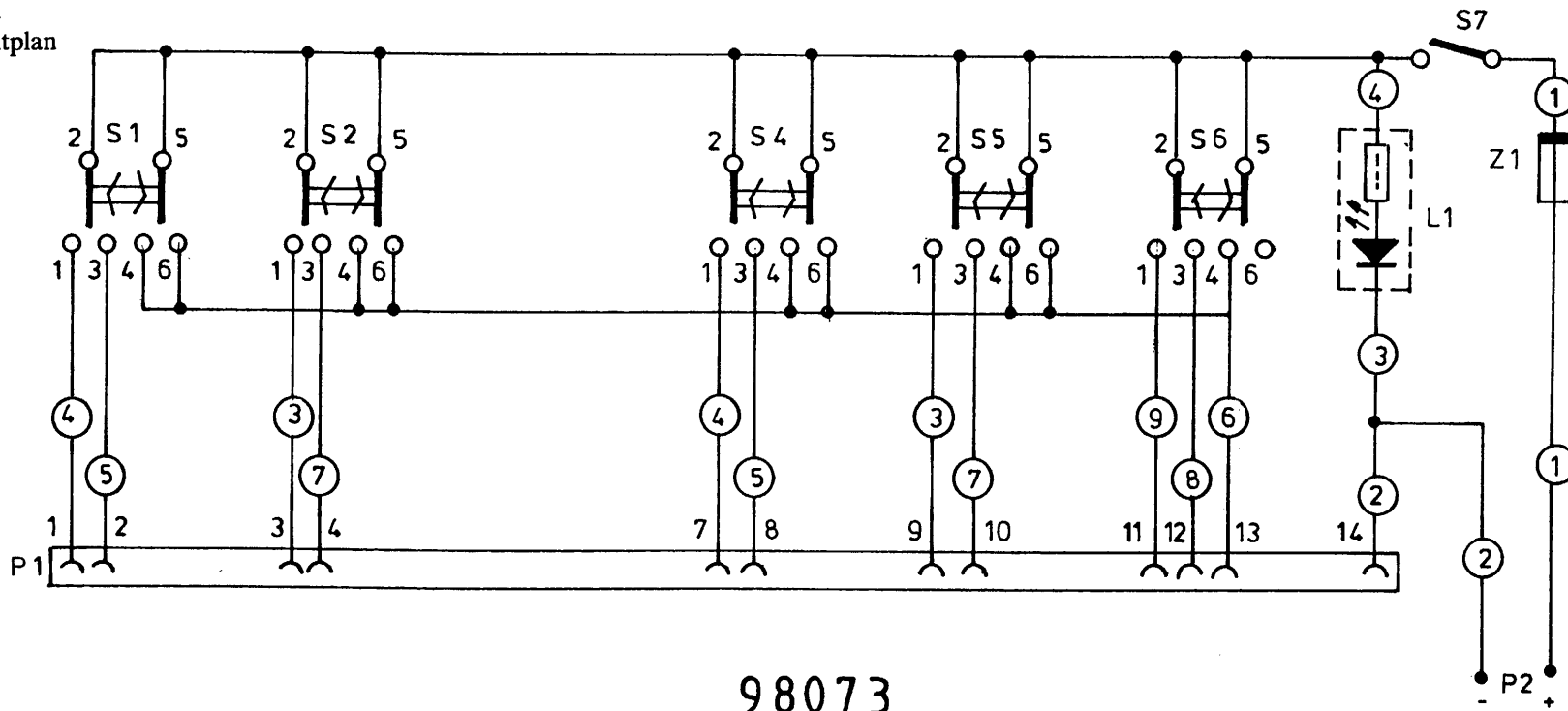

98073

	Kleurcodering	Farbenschlüssel	Colour code	Code des couleurs
1	Bruin	Braun	Brown	Brun
2	Blauw	Blau	Blue	Bleu
3	Geel	Gelb	Yellow	Jaune
4	Rood	Rot	Red	Rouge
5	Oranje	Orange	Orange	Orange
6	Paars	Violet	Purple	Violiet
7	Groen	Grün	Green	Vert
8	Wit	Weiß	White	Blanc
9	Grijs	Grau	Grey	Gris



**TRIO LIET MULLOS BV**

**Smitsbreeuweg 2, 7581 HE Losser - Holland**

**Postbus 202, 7580 AE Losser / Postfach 202, 7580 AE Losser - Holland**

**Tel.: 05423 - 81700 / Tel.: (+) 31 -5423 - 81700**

**Fax 05423 - 87605 / Fax (+) 31 - 5423 - 87605**

***Vanaf 10 oktober 1995***

***Tel. : 053 - 5381700***

***Fax : 053 - 5387605***

***Ab 10. Oktober 1995***

***Tel. : (+) 31 - 53 - 5381700***

***Fax : (+) 31 - 53 - 5381700***