

**TRIO LIET**

*Trioliet*

*Uitkildoseermengwagen  
Siloentnahmewagen*

*Multimix*

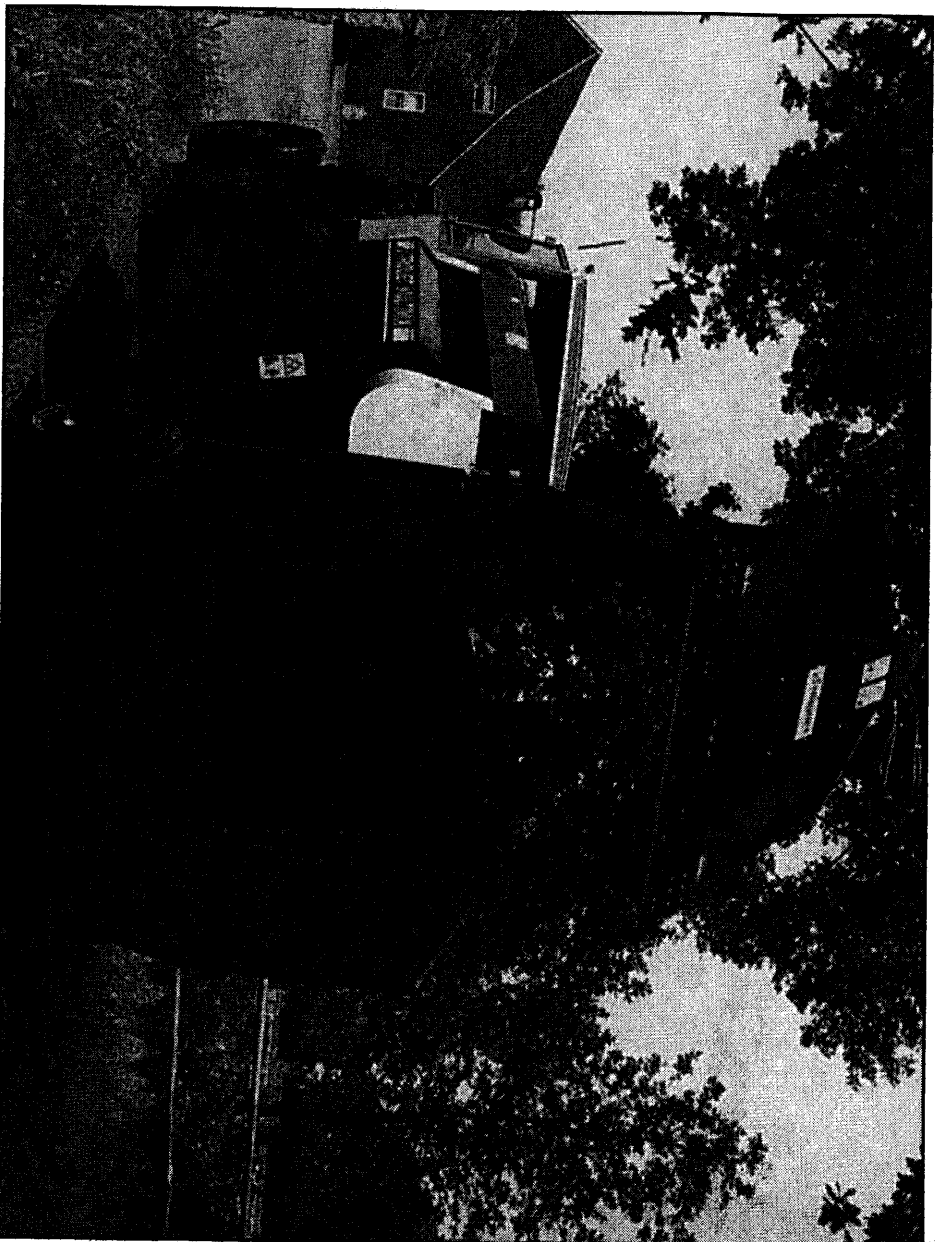

*Onderdelen- en Werkplaatshandboek  
Ersatzteilliste und Werkstatthandbuch*

*Bestelnummer / Bestellnummer 92105*

*Geldig vanaf productieserie nr. / Gültig ab Prod. Series No.: 04*

## INHOUDSOPGAVE:

Afb.

1. Stickers  
Aufkleber
2. Frame  
Rahmen
3. Dissel  
Dechsel
4. Wielstel  
Radachse
- 5A. Mengkettingaandrijving serie 02 - 07  
Mischkettenantrieb Serie 02 - 07
- 5B Mengkettingaandrijving vanaf serie 08  
Mengkettenantrieb ab Serie 08
6. Aandrijving  
Antrieb
7. Tandwielkasten  
Getriebe
8. Teleskoop  
Teleskoparm
- 9A. Snijsteeem serie 04 - 07  
Schneidvorrichtung Serie 04 - 07
- 9B Snijsteeem vanaf serie 08  
Schneidvorrichtung ab Serie 08
10. Slangenloop snijbord  
Schläuche Schneidschild
11. Stuurblok inwendig  
Steuerblock (innenseite)
12. Achter - en zijcilinder  
Hinter - und Seitenmesserszylinder
13. Mechanische afstandsbediening  
Mechanische Fernbedienung

14. Elektrische bediening  
Elektrische Bedienung
15. Bedieningskast en aansluitschema  
Bedieningspult und Schaltplan
16. Schakelcilinder en zijklepcilinder  
Schaltzylinder und Seitenklappezylinder
17. Cilinders teleskoop  
Zylinder Teleskop
18. Dissel- en wielarmcilinder  
Dechsel- und Radarmzylinder
19. Aftakassen  
Gelenkwellen
20. Elektronisch weegstysteem  
Elektronische Waage
21. Hydraulisch schema mechanische bediening  
Hydraulischer Schaltplan mechanische Fernbedienung
22. Hydraulisch schema elektrische bediening  
Hydraulischer Schaltplan elektrische Fernbedienung
23. Elektrisch schema  
Elektrischer Schaltplan

**92105/2**

Afbeelding 1 : Stickers  
 Abbildung 1 : Aufkleber

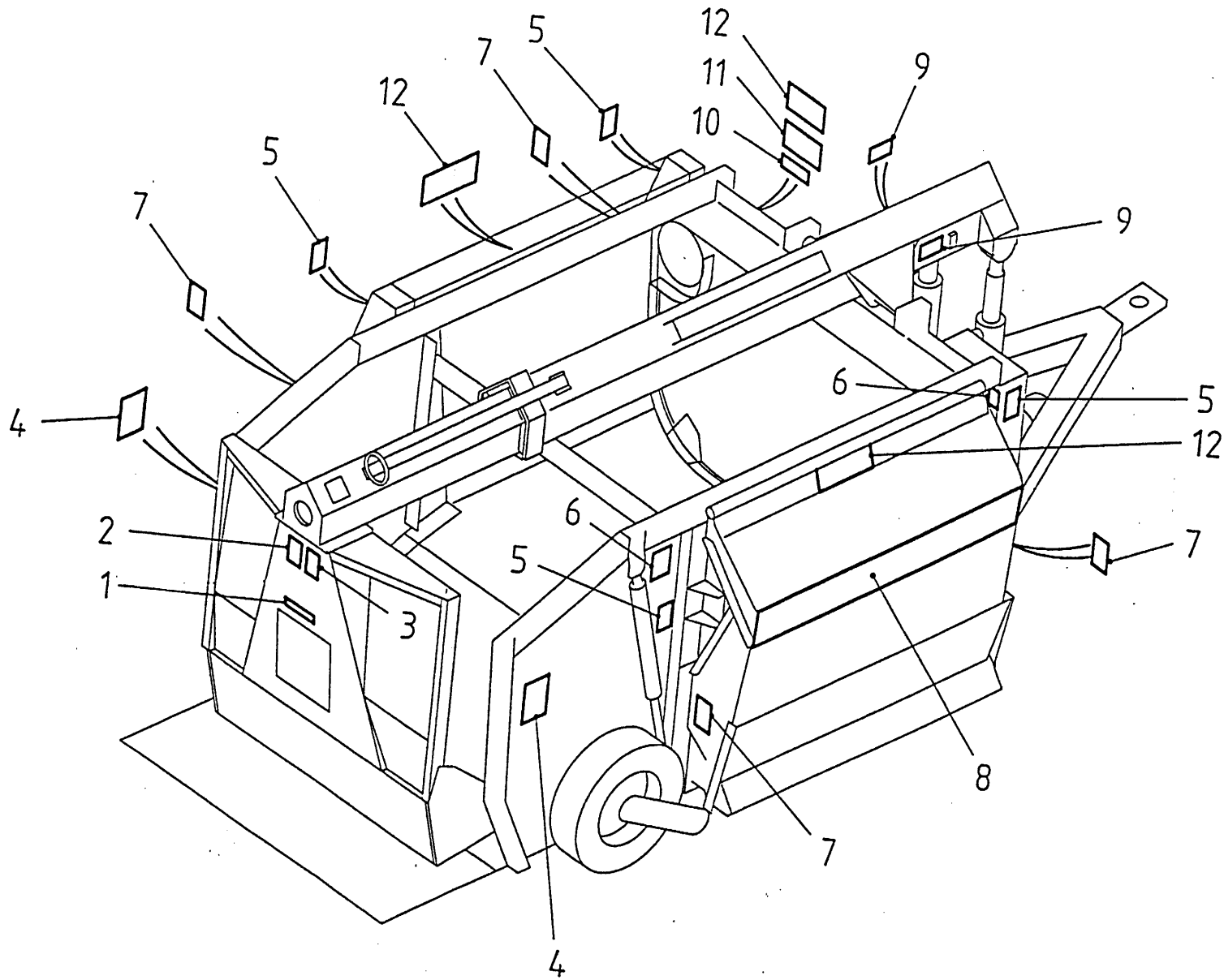

bestelnummer		
ordernummer		
num.à commander		
Bestellnummer		
1	91002	1
2	91153	1
3	91163	1
4	91172	2
5	91152	4
6	91128	2
7	91180	4
8	91178	2
9	91151	2
10	91159	1
11	91160	1
12	91164	3
13	91185	1
14	91190	1
15	91182	2
16	91183	4
17	91189	1
18	91118	2

92105/2

Afbeelding 2 : Frame  
 Abbildung 2 : Rahmen

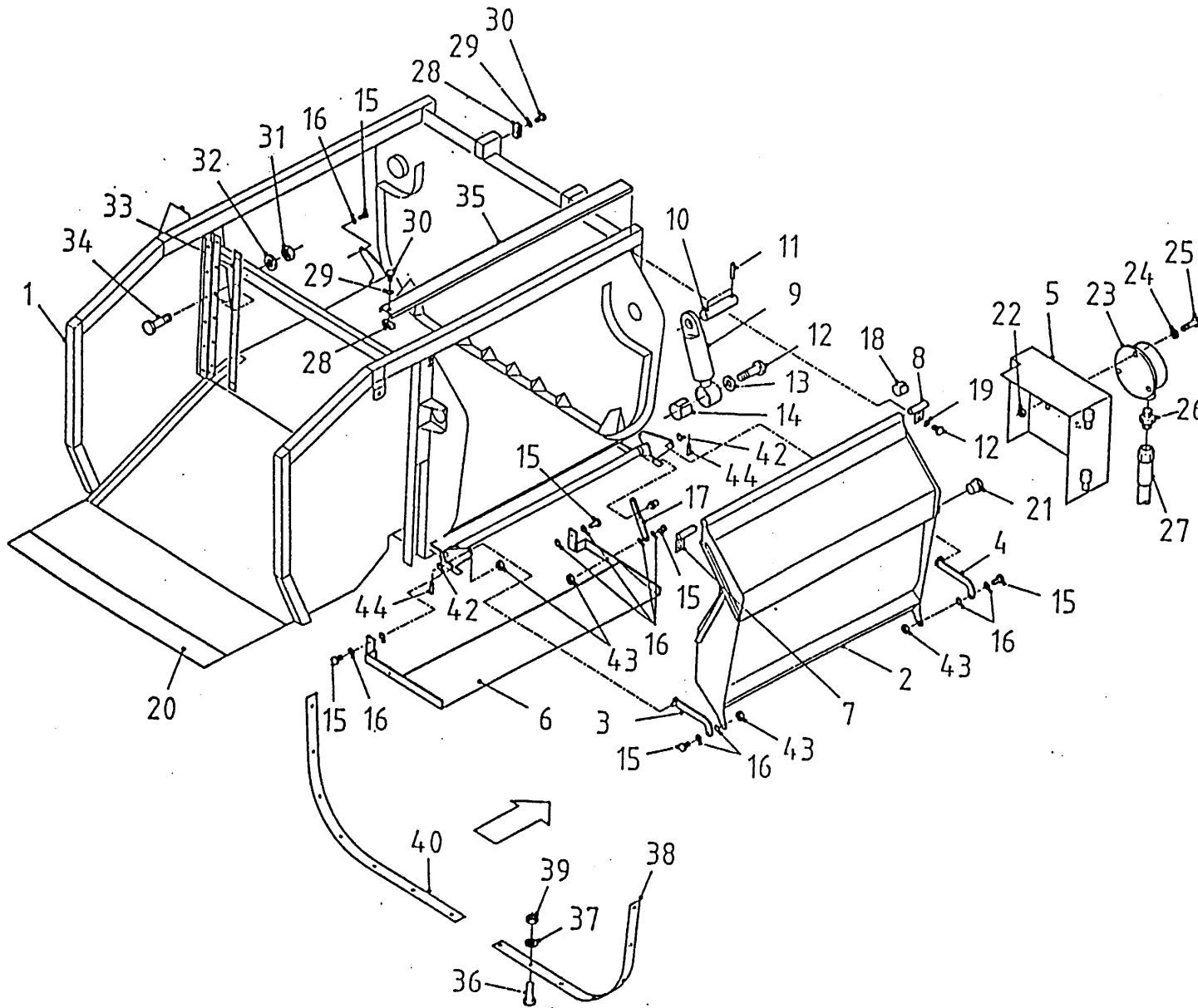

bestelnummer  
 ordernummer  
 Num. à commander  
 Bestellnummer

1	11208	1	
2	11207	1	
3A	11261	2	→I 05
3B	11740	2	I→ 06
4A	11262	2	→I 05
4B	11739	2	I→ 06
5	22056	1	
6	11180	2	
7	11188	2	
8	11183	2	
9	50100	2	
10	31379	2	
11	88029	4	∅ 4 x 30
12	81226	10	M12 x 25
13	85115	2	M12
14	51797	2	
15A	84919	16	M12 →I 05
15B	81651	10	M16 x 50 I→
16A	85121	16	M12 →I 05
16B	85116	20	M16 I→ 06
17	22807	2	
18	51805	4	
19	85112	8	M12
20	23225	1	
21	60228	4	
22	86205	3	M5
23	53197	1	
24	85105	3	M5
25	80516	3	M5 x 16
26	X50415	1	
27	W50787	1	¼" 600 RZH Z
28	90159	4	
29	85108	4	M8
30	84401	4	M8 x 40
31	86208	10	M8
32	85108	10	M8
33	60206	2	
34	80826	10	M8 x 25
35	40300	1	

**92105/2**

Afbeelding 2 : Frame  
 Abbildung 2 : Rahmen

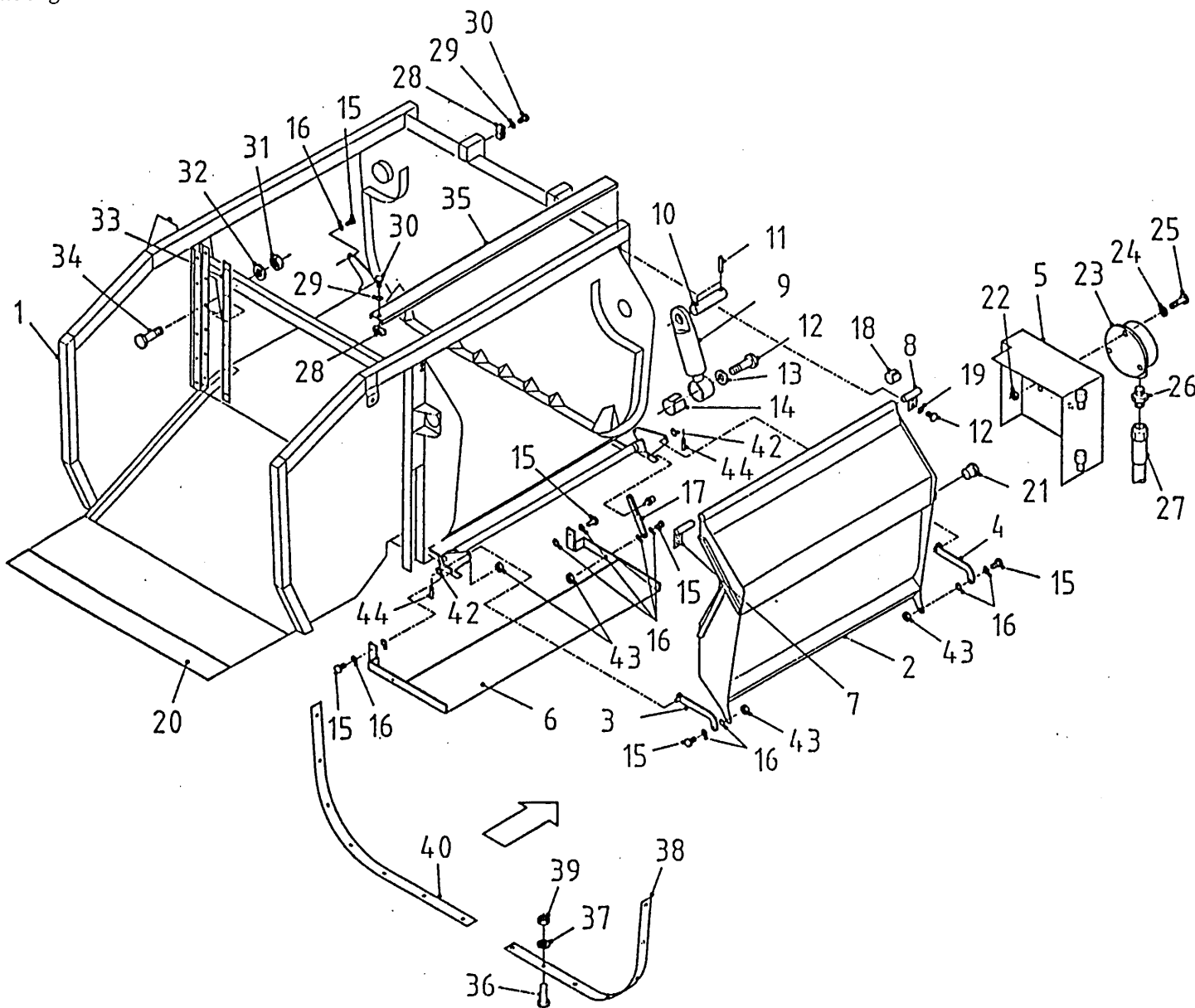

bestelnummer  
 ordernummer  
 Num. à commander  
 Bestellnummer

36	84194	32	M6 x 40
37	85406	32	M6
38	60227	2	Rechts
39	86606	32	M6
40	60226	2	Links
42	85116	6	M16 l → 06
43	86216	26	M16 l → 06
44	88027	6	Ø 6 x 26 l → 06

**92105/2**

Afbeelding 3 : Dissel  
 Abbildung 3 : Deichsel

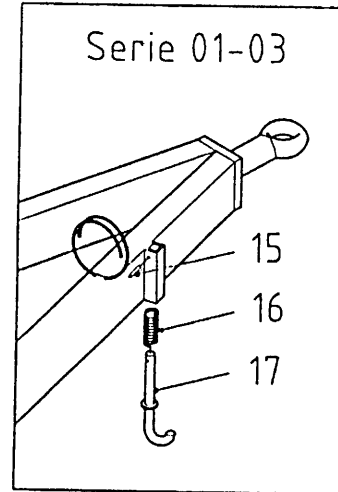
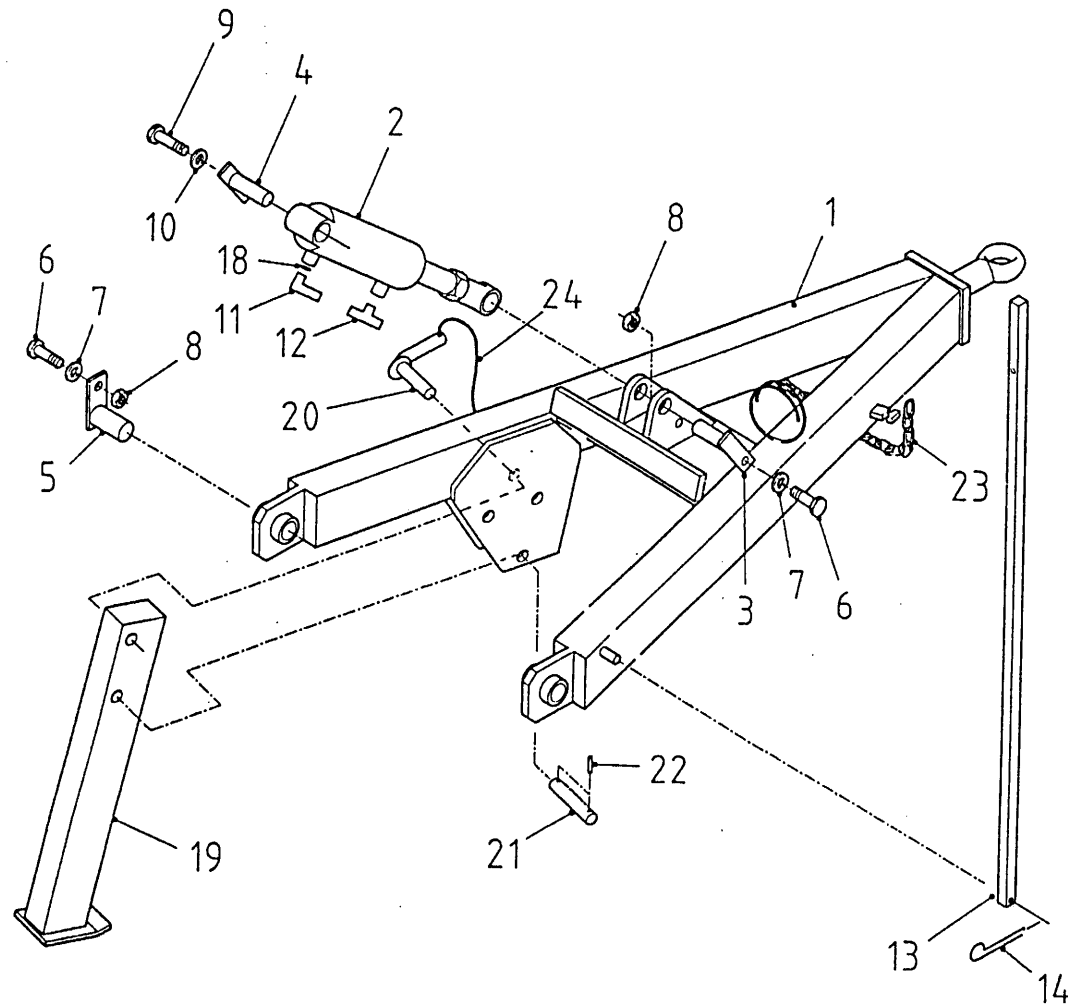

bestelnummer  
 ordernummer  
 Num. à commander  
 Bestellnummer

1	11233	1	
2	51006	1	
3	11223	1	
4	11225	1	
5	11215	2	
6	81035	3	M10 x 35
7	85110	3	M10
8	86210	3	M10
9	81031	1	M10 x 30
10	85010	1	M10
11	X5010	1	
12	X5035	1	
13	22953	1	
14	88242	1	Ø 3,5 x 40
15	88028	1	Ø 5 x 28 → I 03
16	65061	1	→ I 03
17	11439	1	→ I 03
18	53172	1	Ø 1 mm
19	11735	1	I → 04
20	11736	1	I → 04
21	31548	1	I → 04
22	88030	2	Ø 6 x 30 I → 04
23	39136	1	I → 04
24	90282	1	I → 04

92105/2

Afbeelding 4 : Wielset

Abbildung 4 : Radachse

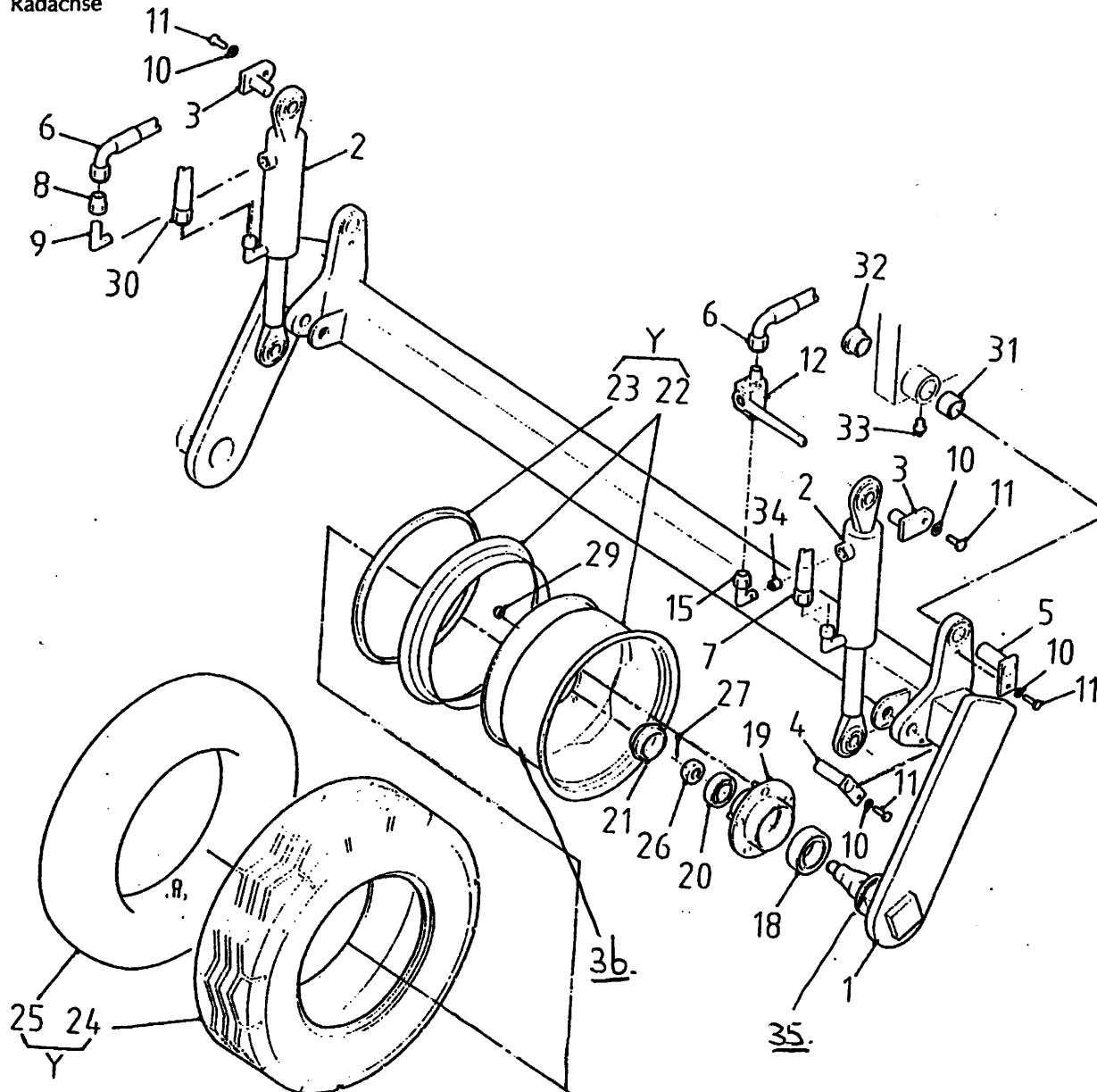

bestelnummer  
ordernummer  
num.à commander  
Bestellnummer

1A	11548	1	21,5 mm → I 05
1B	11812	1	0 mm I → 06
2A	51002	2	→ I 02
2B	51066	2	I → 03
3	11532	2	
4	11198	2	
5	11204	2	
6	W50795	2	3/8" 3550 RHZ
7	W50785	1	3/8" 4500 RH
8	X50154	1	
9	X50101	1	
10	85008	6	M 8
11	80821	6	M 8 x 20
12	51023	1	
15	50103	1	
18	70057	2	
19	90308	2	
20	70056	2	
21	90225	2	
22A	90288	2	21,5 mm → I 05
22B	90408	2	0 mm I → 06
23	90292	2	
24	90290	2	
25	90291	2	
26	90223	2	
27	90224	2	
29	86922	12	M18 x 1,5
30	W50796	1	3/8" 5050 RR
31	51843	2	
32	51747	2	
33	89503	2	
34	53183	1	0,65 mm
Y1	90289	2	21,5 mm → I 05
Y2	90407	2	0 mm I → 06
35	90399		
36	90752		



**92105/2**

Afbeelding 5A : Mengkettingaandrijving serie 02 - 07

Abbildung 5A : Mengkettenantrieb Serie 02 - 07

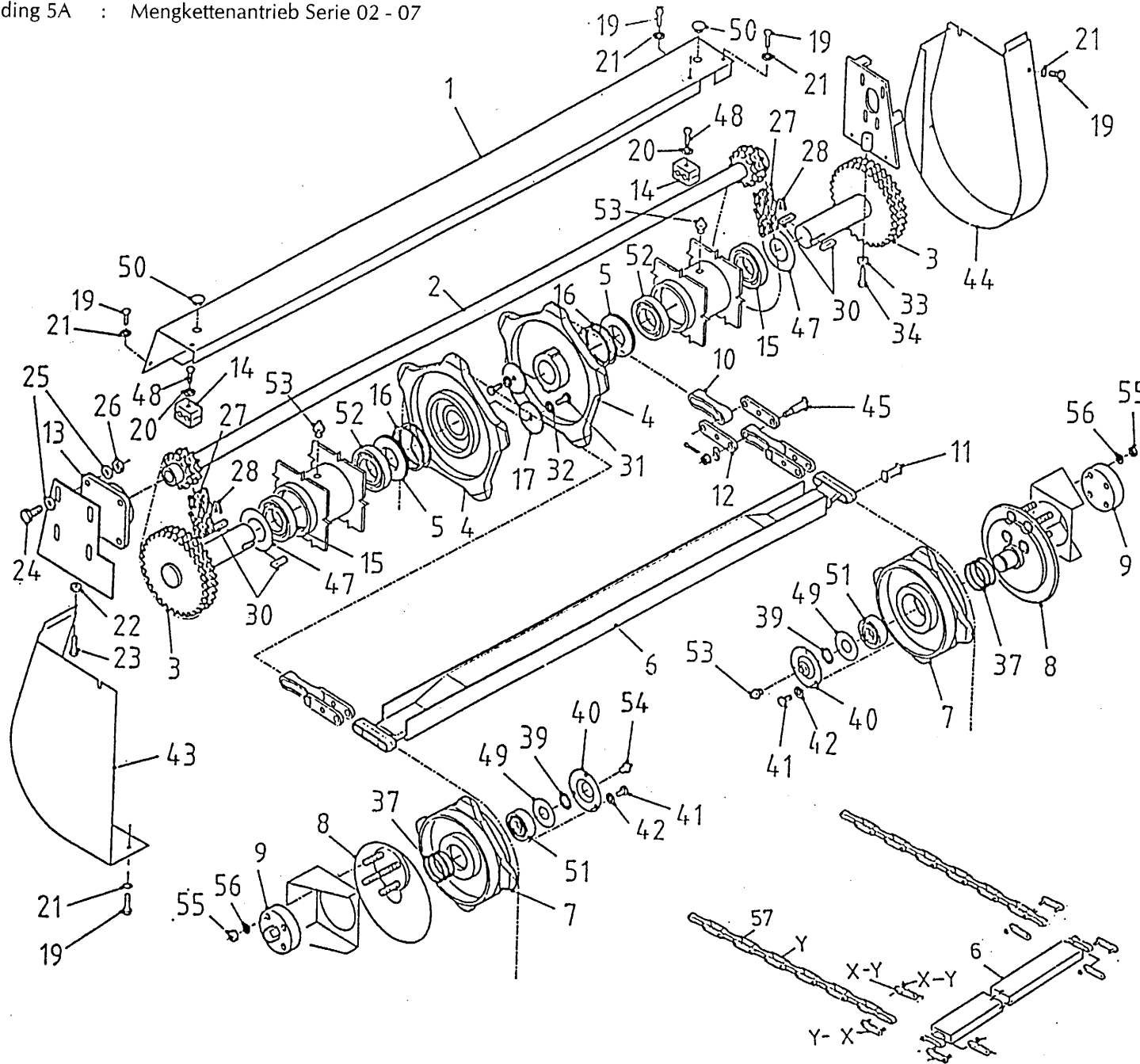

bestelnummer		ordernummer	
Num. à commander		Bestellnummer	
1	40318	1	
2	11331	1	
3	11330	2	
4	39109	2	
5	31093	2	
6A	11336	5	→ I 03
6B	11749	5	I → 04
7	39110	2	
8A	11344	2	e=40 → I 03
8B	11666	2	e=70 I → 04
9A	10807	2	→ I 03
9B	11667	2	I → 04
10	39101	48	→ I 05
11	39102	114	→ I 05
12	39100	116	→ I 05
13	70081	1	
14	90159	1	
15	70079	2	6212 2RS
16	70080	2	
17	22608	2	
19	80612	11	M6 x 12
20	85108	2	M8
21	85106	11	M6
22	86112	1	M12
23	81239	1	M12 x 140
24	81241	4	M12 x 40
26	86212	4	M12
27	39098	2	
28	39099	2	
30	88337	4	18 x 11 x 40
31	81025	2	M10 x 25
32	85110	2	M10
33	86116	1	M16
34	81690	1	M16 x 90
37	70072	2	
39	87035	2	
40	24414	2	

92105/2

Afbeelding 5A : Mengkettingaandrijving serie 02 - 07

Abbildung 5A : Mengkettenantrieb Serie 02 - 07

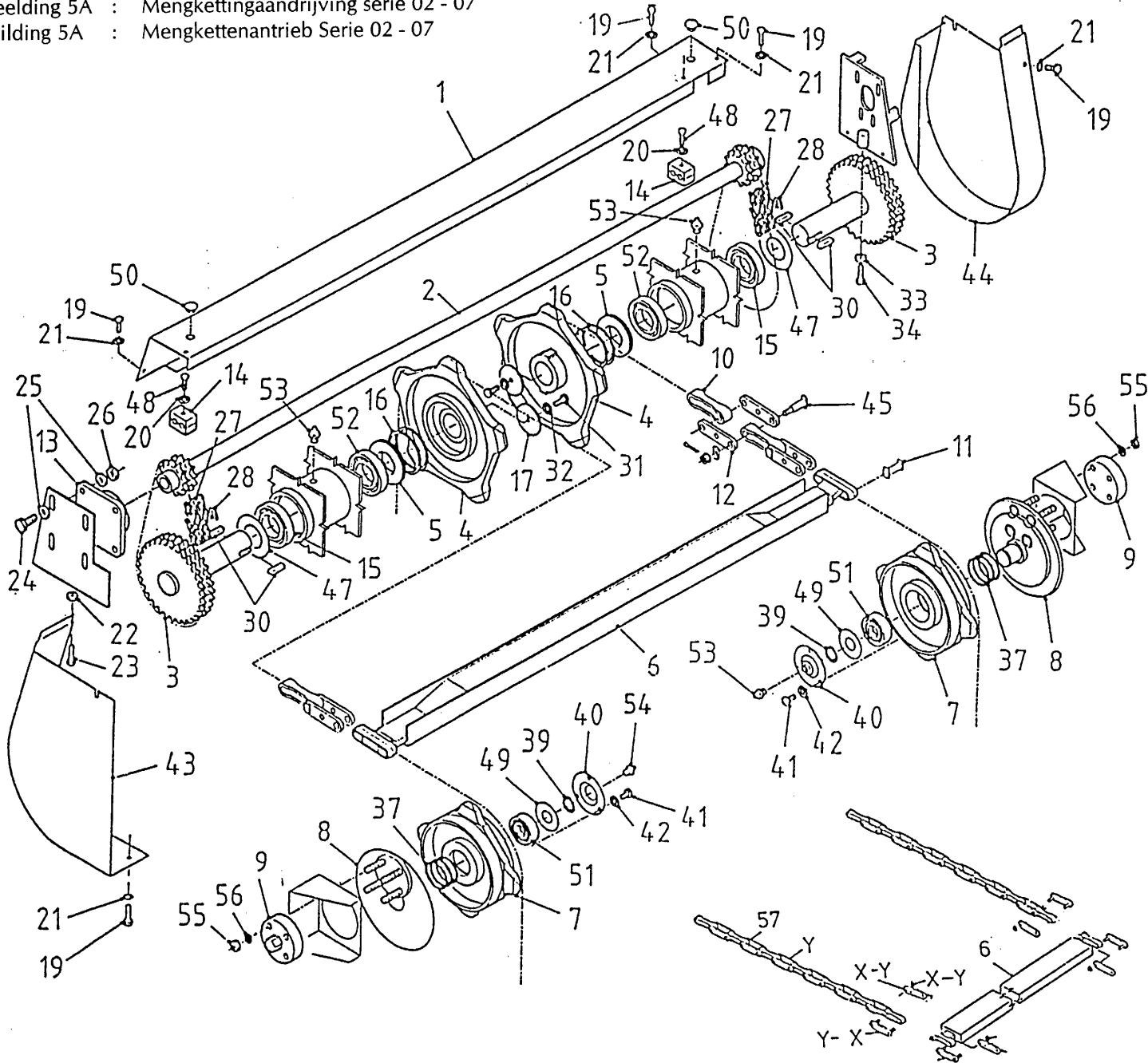

bestelnummer  
ordernummer  
Num. à commander  
Bestellnummer

41	80612	6	M6 x 12
42	85106	6	M6
43	11337	1	
44	11340	1	
45	39106	2	→ I 05
47	85360	2	
48	84401	2	M8 x 40
49	85335	2	
50	90315	2	
51A	70075	2	→ I 02 3207
51B	70095	2	→ 03 3207 Z
52	70097	2	6212Z
53	89503	2	M6
54	89519	2	M8
55	86216	8	M16
56	85116	8	M16
57A	39167	2	L = 714,7
57B	39168	8	L = 918,9
X	39165	20	
Y	05367	1	

92105/2

Afbeelding 5B : Mengkettingaandrijving vanaf serie 08

Abbildung 5B : Mengkettenantrieb ab Serie 08

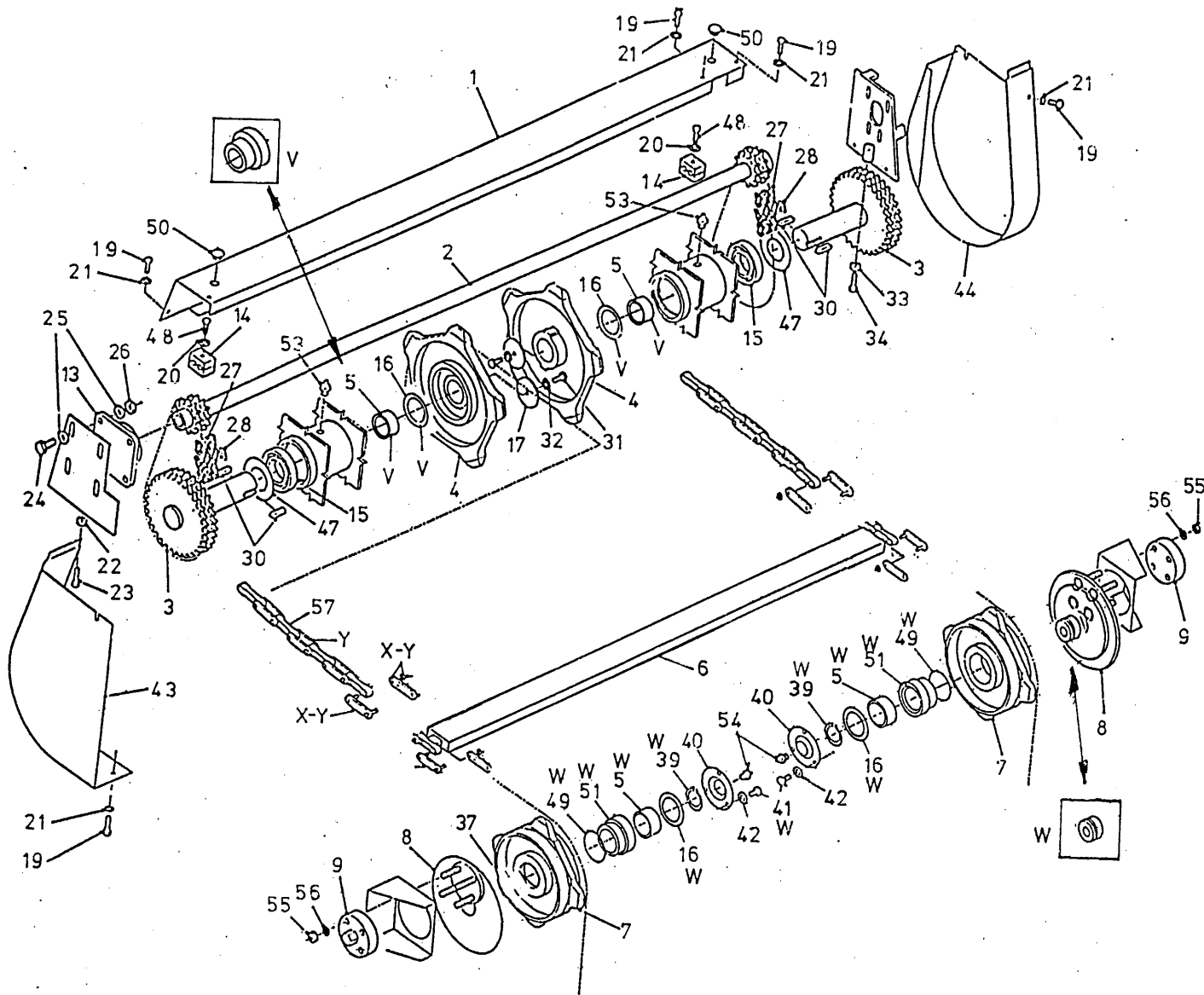

bestelnummer  
ordernummer  
Num. à commander  
Bestellnummer

1	40318	1	
2	11331	1	
3	11330	2	
4	39109	2	
5	51868	4	
6	11749	5	
7	39110	2	
8	11666	2	e=70
9	11667	2	
13	70081	1	
14	90159	1	
15	70079	2	6212 2RS
16	85360	4	
17	22608	2	
19	80612	11	M6 x 12
20	85108	2	M8
21	85106	11	M6
22	86112	1	M12
23	81239	1	M12 x 140
24	81241	4	M12 x 40
26	86212	4	M12
27	39098	2	
28	39099	2	
30	88337	4	18 x 11 x 40
31	81025	2	M10 x 25
32	85110	2	M10
33	86116	1	M16
34	81690	1	M16 x 90
37	70072	2	
39	87060	2	
40	24414	2	

**92105/2**

Afbeelding 5B : Mengkettingaandrijving

Abbildung 5B : Mengkettenantrieb

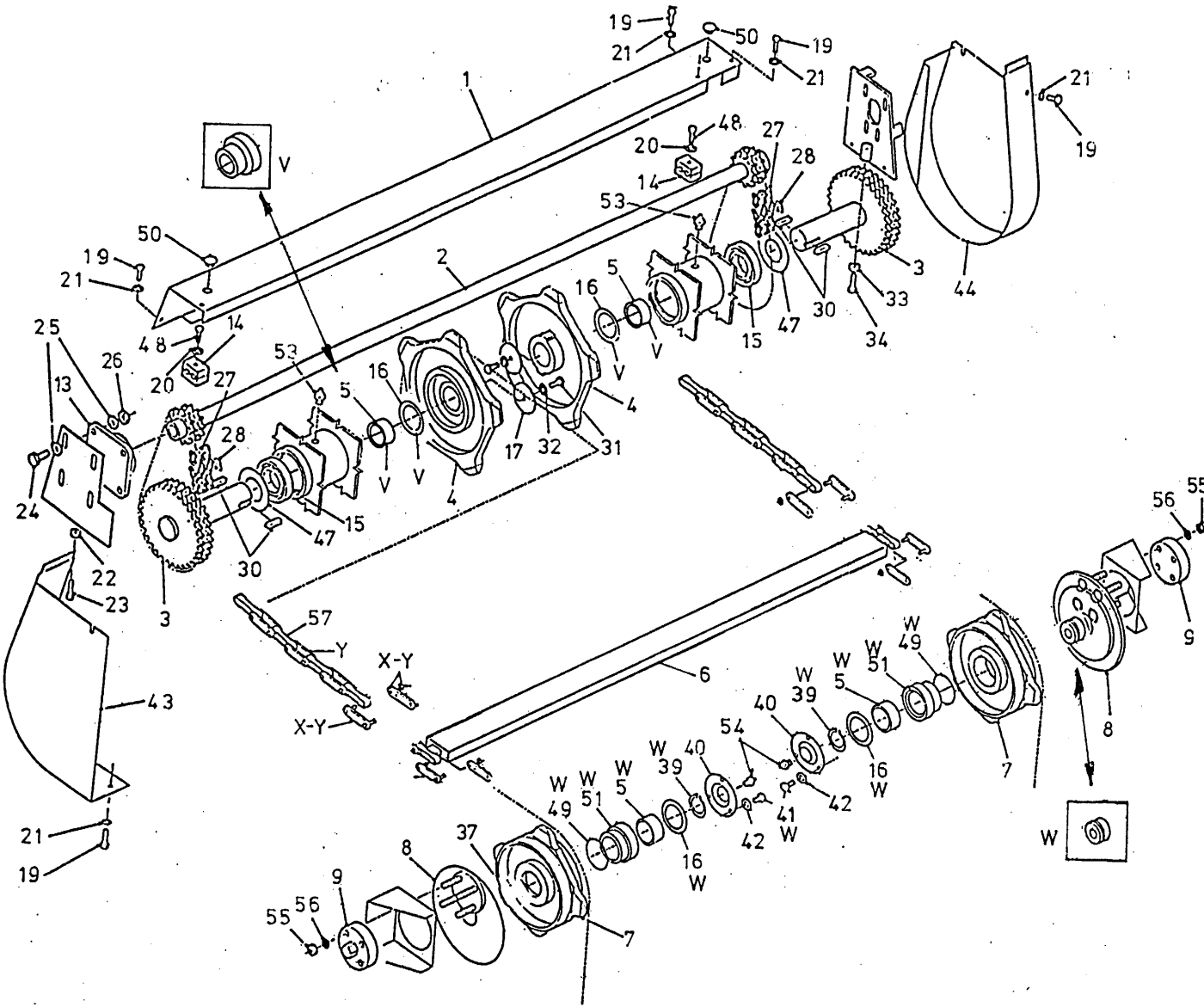

bestelnummer  
 ordernummer  
 Num. à commander  
 Bestellnummer

41	80635	6	M6 x 35
42	85106	6	M6
43	11337	1	
44	11340	1	
47	85360	2	
48	84401	2	M8 x 40
49	78136	2	
50	90315	2	
51	31844	2	
54	89519	2	M8
55	86216	8	M16
56	85116	8	M16
57A	39167	2	L = 714,7
57B	39168	8	L = 918,9
X	39165	20	
Y	05367	1	
V	05376	1	
W	05377	1	

92105/2

Afbeelding 6 : Aandrijving

Abbildung 6 : Antrieb

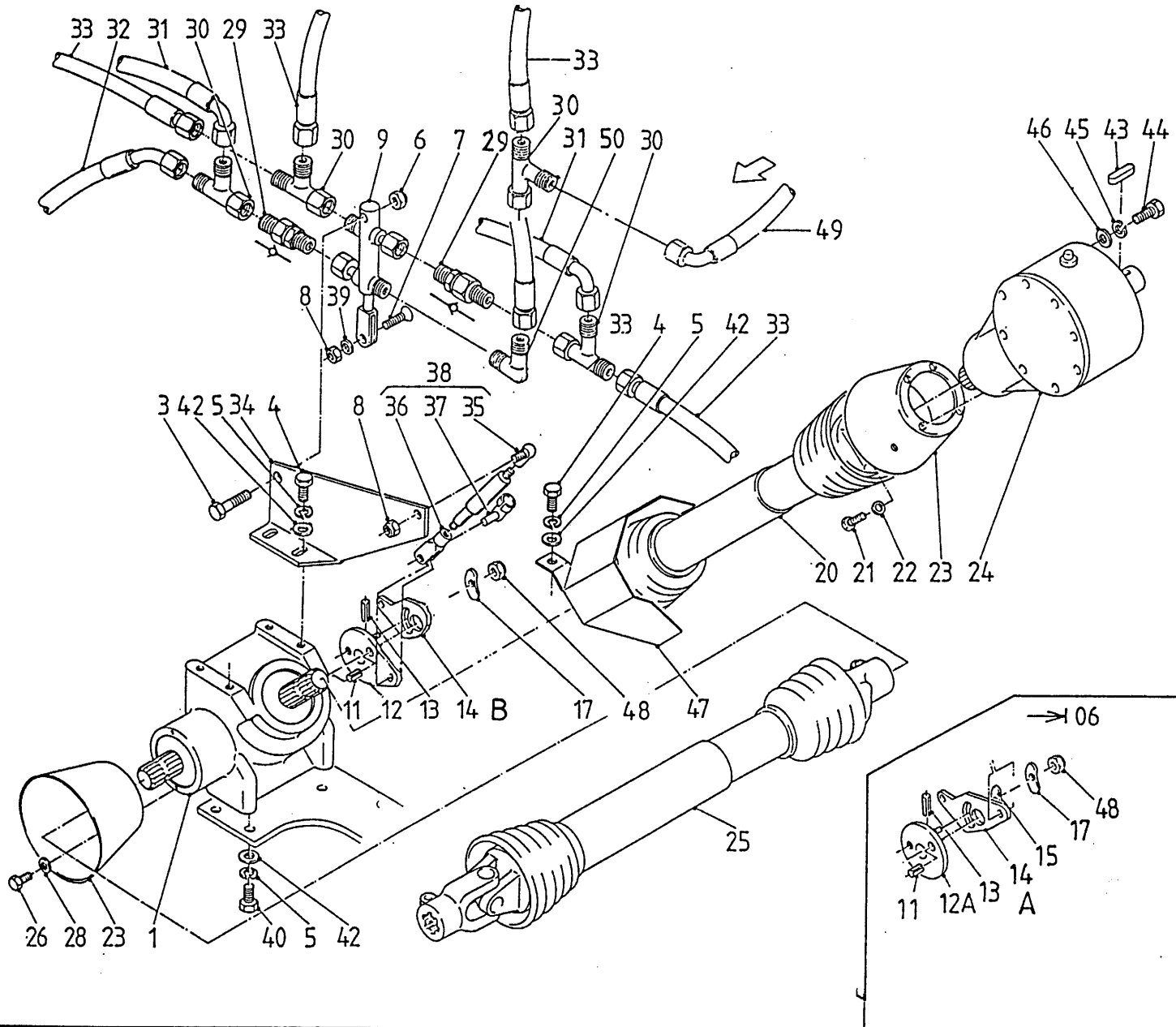

bestelnummer  
ordernummer  
Num. à commander  
Bestellnummer

1	90226	1	
3	81045	1	M10 x 45
4	81226	5	M12 x 25
5	85012	7	M12
6	86210	1	M10
7	84183	1	M8 x 30
8	86208	1	M8
9A	51024	1	→I 02 75 mm
9B	51098	1	→I 03 85 mm
11	88015	1	Ø 8 x 16
12A	11543	1	→I 06
12B	12030	1	→I 07
13	88030	1	Ø 6 x 30
14A	24547	1	→I 06
14B	25578	1	→I 07
15	60211	1	→I 06
17	11845	1	
20	90233	1	
21	81016	2	M10 x 16
22	85113	2	M10
23	90284	2	
24	90227	1	
25	90232	1	
26	80816	2	M8 x 16
28	85109	2	M8
29	X53018	2	
30	X50300	4	
31	W50719	2	¼" 900 RH
32	W50806	3	¼" 950 R45°
33	W50807	4	¼" 1050 RR
34	11544	1	
35	70092	1	
36	31293	1	
37	31675	1	
38	90316	1	
39	85108	1	M8

92105/2

Afbeelding 6 : Aandrijving  
 Abbildung 6 : Antrieb

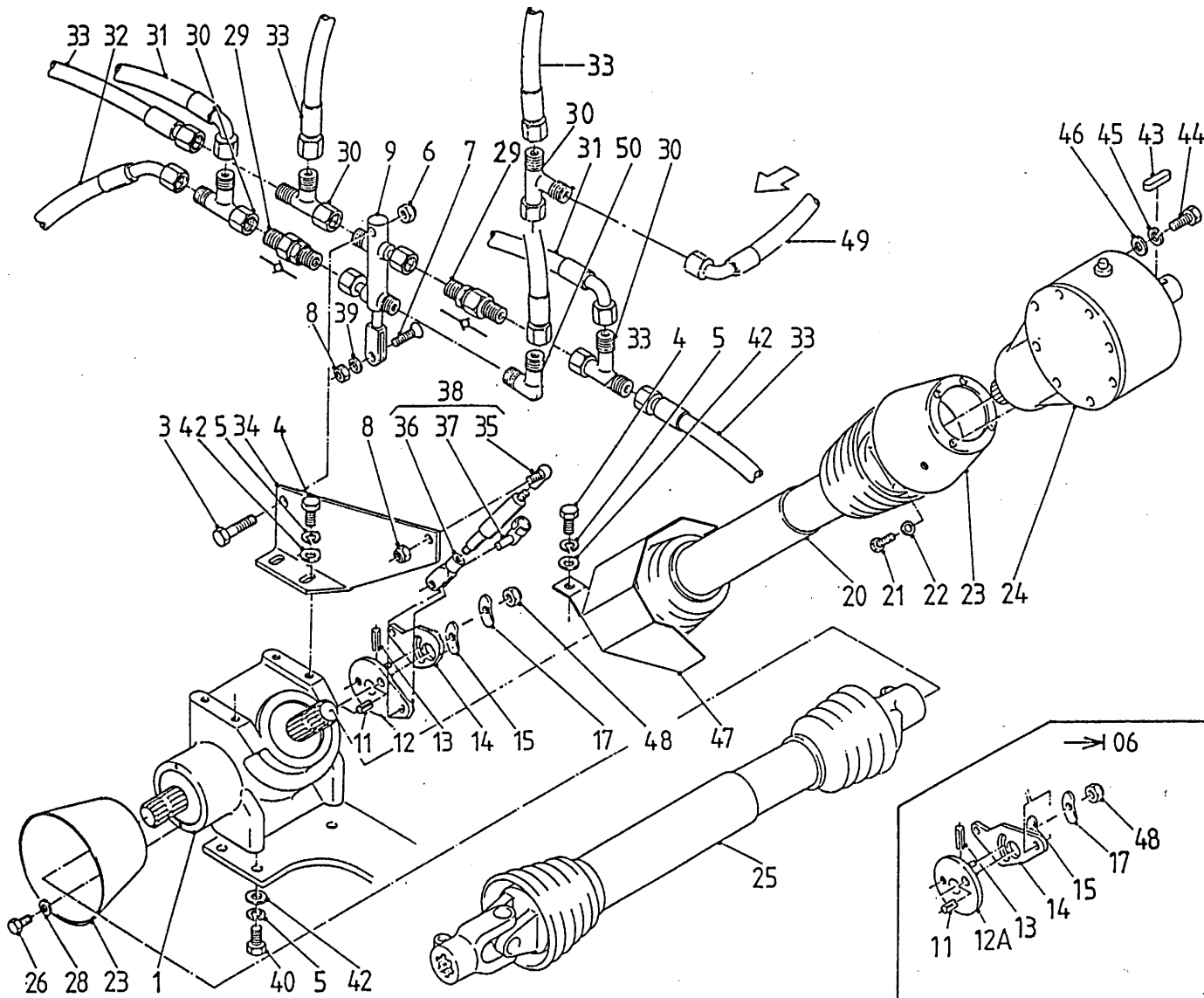

	bestelnummer	ordernummer	Num. à commander	Bestellnummer
40	81236	4	M12 x 35	
41	85012	9	M12	
42	85112	9	M12	
43	88358	1	14 x 9 x 61	
44	81641	4	M16 x 40	
45	85016	4	M16	
46	85116	4	M16	
47	11557	1		
48	86212	1	M12	
49	W50743	1	¼" 1200 RH	
50	50107	1		
51	65070	1		

92105/2

Afbeelding 7 : Tandwielkasten

Abbildung 7 : Getriebe

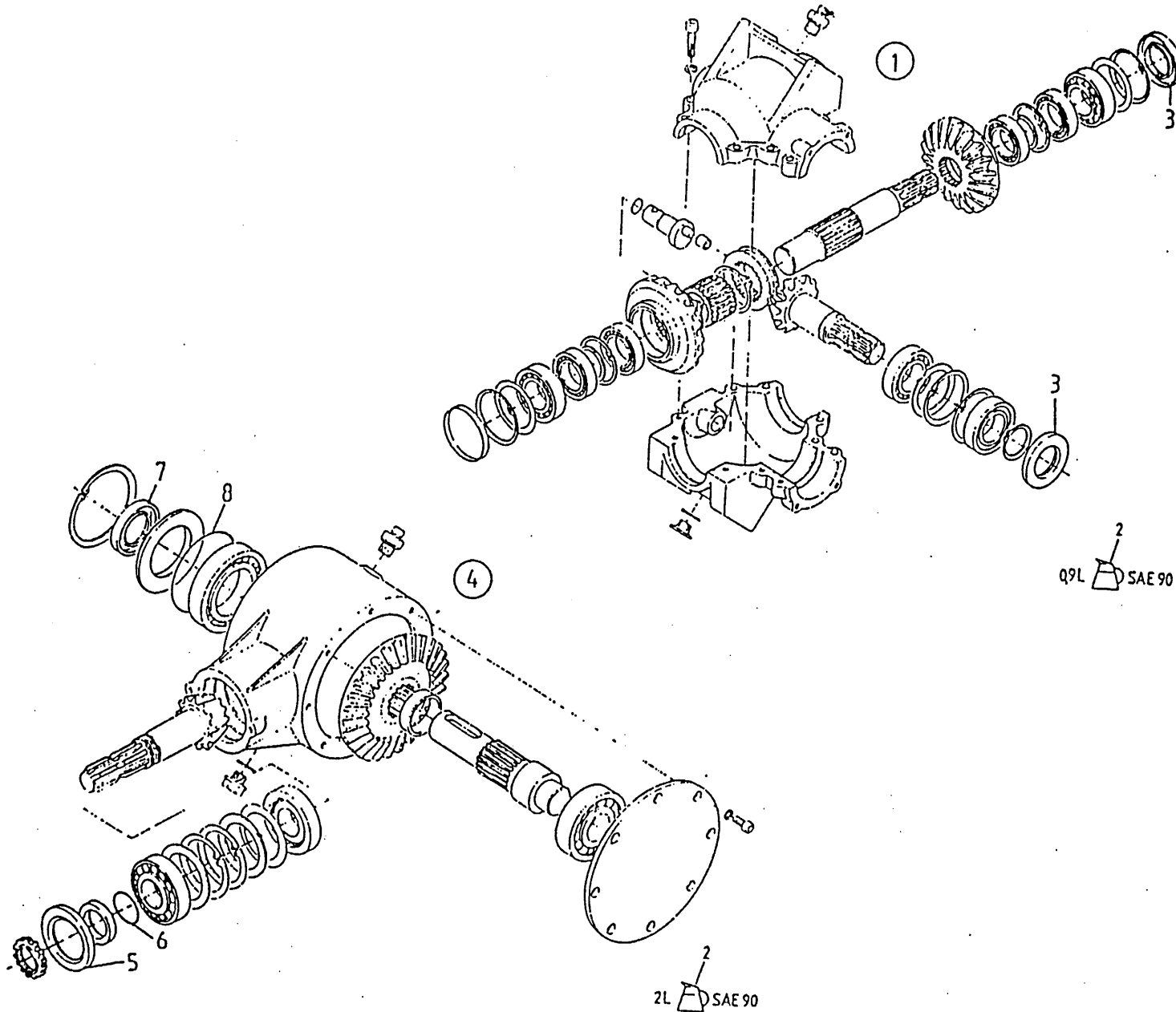

bestelnummer  
 ordernummer  
 Num. à commander  
 Bestellnummer

1	90226	1	
2	90307	0,9L	
3	70109	2	40 x 80 x 10
4	90227	1	
2	90307	2L	
5	70108	1	60 x 90 x 8
6	78011	1	40 x 3
7	70107	1	45 x 80 x 10
8	78102	1	115 x 2,5

**92105/2**

Afbeelding 8 : Telescoop  
 abbildung 8 : Teleskoparm

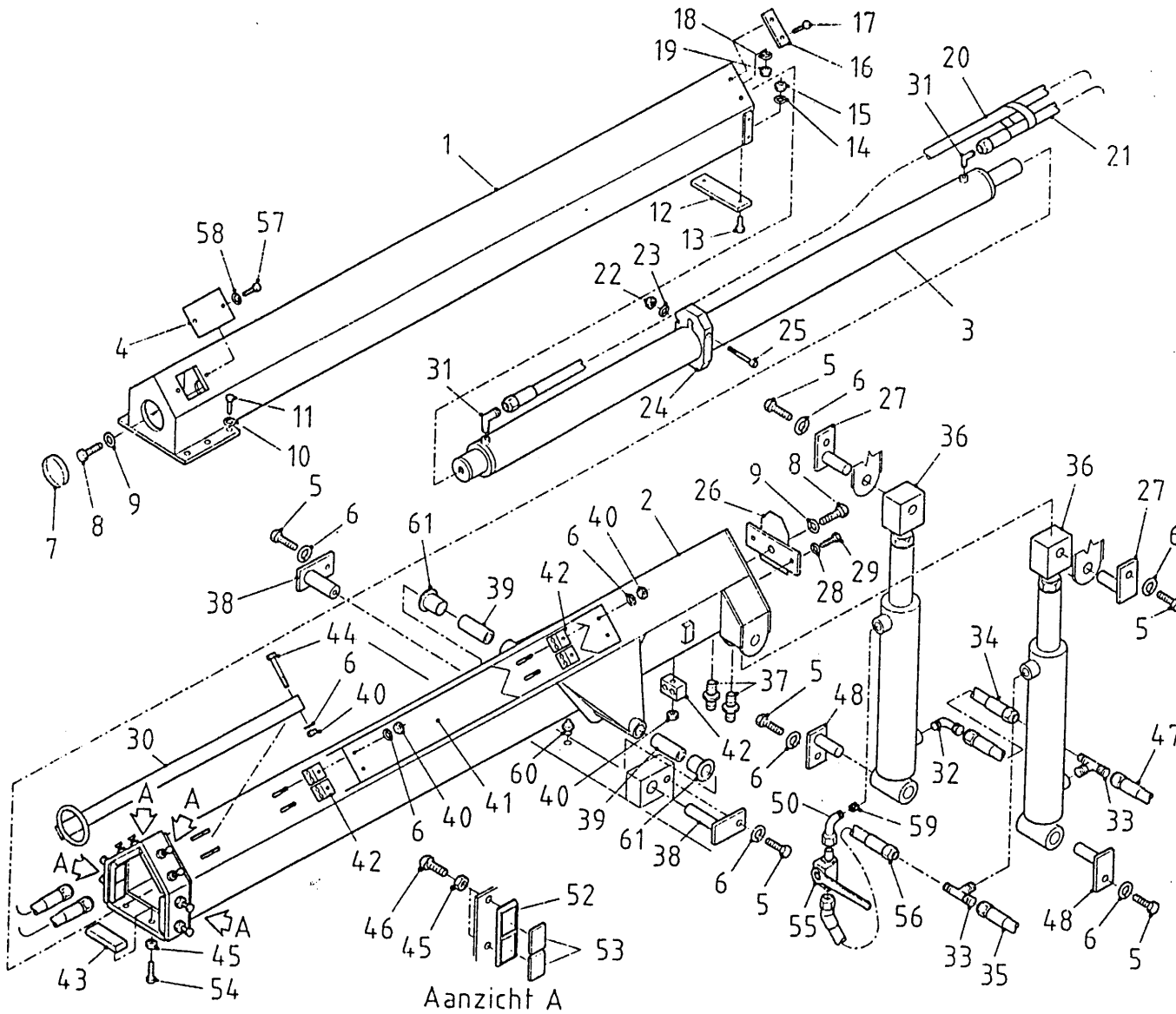

bestelnummer  
 ordernummer  
 num.à commander  
 Bestellnummer

1	11211	1	
2	11210	1	
3	51005	1	
4	22907	1	
5	81021	6	M 10 x 20
6	85010	7	M 10
7	60202	1	
8	81860	2	M 18 x 60
9	85018	2	M 18
10	85020	6	M20
11	84435	6	M 20 x 45
12	60203	1	
13	84102	2	M 10 x 30
14	85110	2	M 10
15	86210	2	M 10
16	22904	4	
17	84123	8	M 6 x 20
18	85106	8	M 6
19	86206	8	M 6
20	W50784	1	½" 2250 RR
21	W50783	1	½" 700 RR
22	86210	1	M 10
23	85110	1	M 10
24	60205	1	
25	84434	1	M 10 x 100
26	11214	1	
27	11223	2	
28	85116	2	M 16
29	81641	2	M 16 x 40
30	11213	1	
31	X50101	2	
32	X50103	1	
33	X50356	2	
34	W50792	1	¾" 300 45°Z 45°Z
35	W50790	1	¾" 4500 RHZ
36A	51007	2	Serie 01
36B	51033	2	Serie 02
36C	51067	2	↳ 03



92105/2

Afbeelding 8 : Telescoop  
 abbildung 8 : Teleskoparm

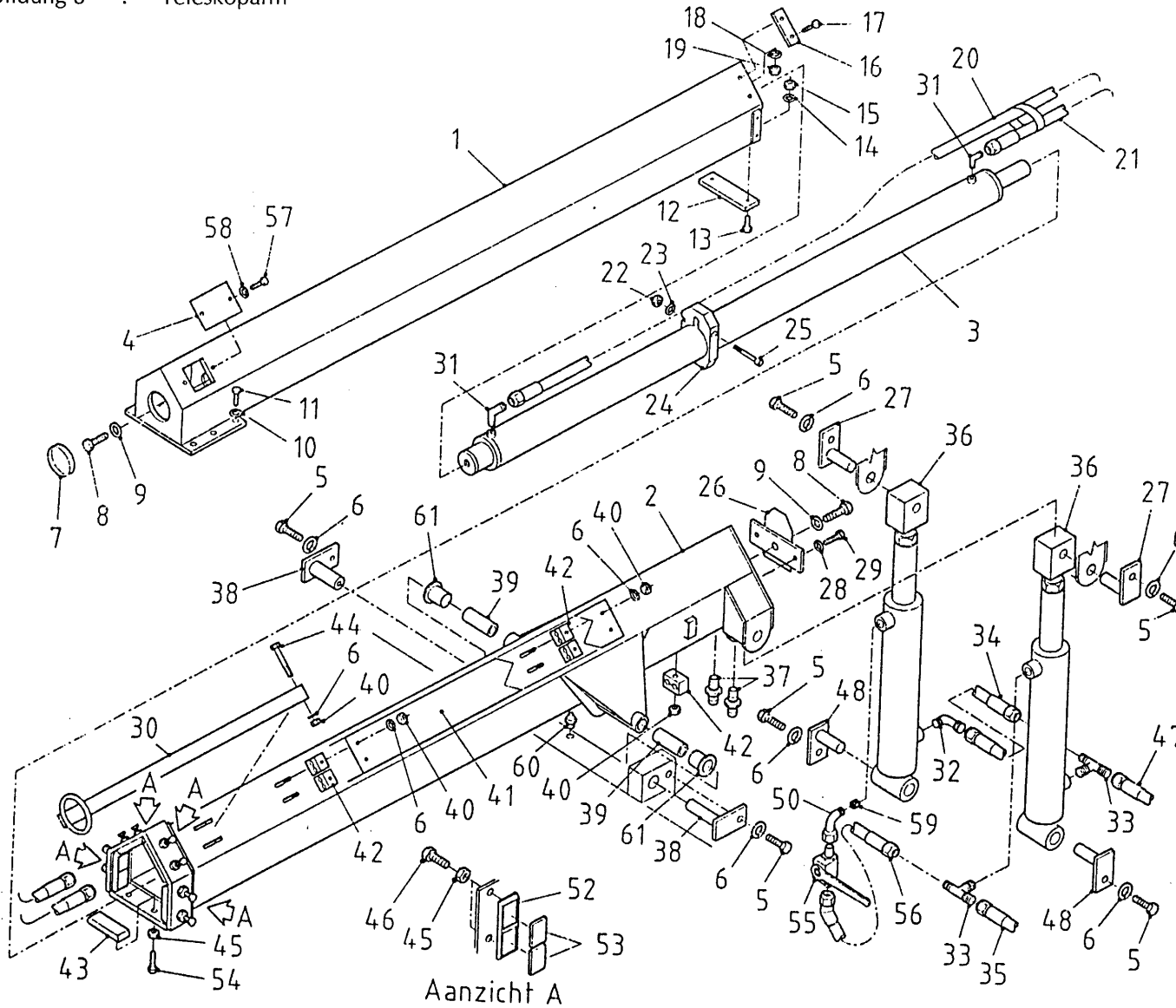

bestelnummer  
 ordernummer  
 num.à commander  
 Bestellnummer

37	X50500	2	
38A	11226	2	→ I 03
38B	11748	1	→ 04
39	51760	2	
40	86208	5	M 8
41	40299	1	
42	90159	5	
43A	60204	1	→ I 01
43B	60221	1	→ 02
44	80880	1	M 8 x 80
45	86116	10	M 16
46	81661	8	M 16 x 60
47	W50808	1	3/8" 5200 RHZ
48	11224	2	
50A	X50146	1	→ I 02
50B	X50103	1	→ 03
52	21888	4	
53	60145	8	
54	81671	2	M 16 X 70
55	51023	1	
56	W50810	1	3/8" 400 RZ 45° Z
57	80816	2	M 8 x 16
58	85008	2	M 8
59	53187	1	0,8 mm
60	89503	1	M6
61	51854	2	→ 04

**92105/2**

Afbeelding 9A : Snijstelsel t/m serie 07

Abbildung 9A : Schneidvorrichtung bis einschl. Serie 07

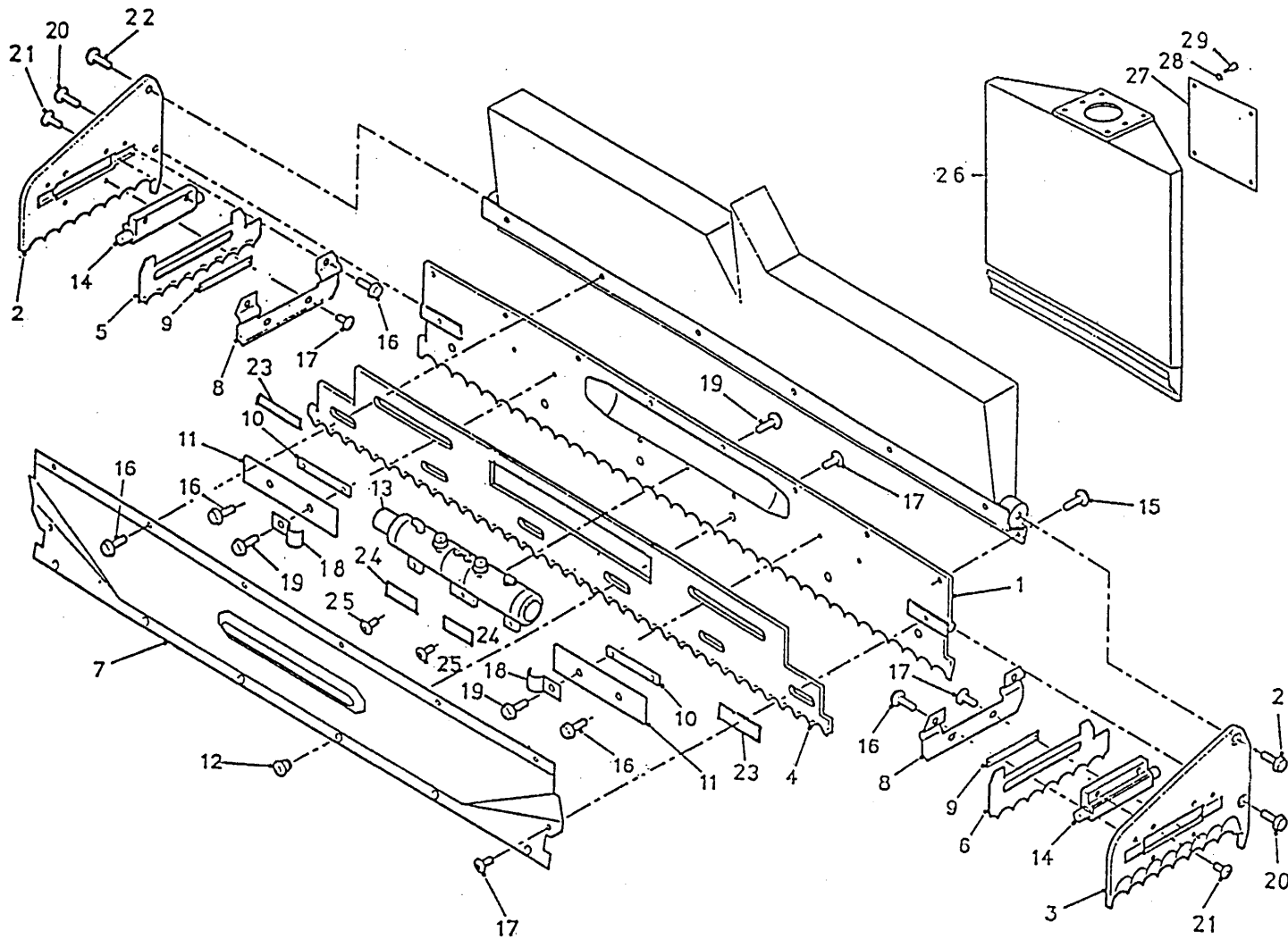

bestelnummer  
 ordernummer  
 num.à commander  
 Bestellnummer

1	11508	1	
2A	11659	1	Rechts serie 04
2B	11708	1	Rechts l→ 05
3A	11658	1	Links serie 04
3B	11707	1	Links l→ 05
4A	24545	1	→l 06
4B	25655	1	l→07
5A	24543	1	Rechts →l 06
5B	25652	1	Rechts l→07
6A	25652	1	Links →l 06
6B	25652	1	Links l→07
7	11596	1	
8	23853	2	
9A	23854	2	BR=20 →l 06
9B	25657	2	BR=15 l→07
10	23854	4	
11	23848	2	
12	31327	8	
13A	51061	1	18 mm 1 ring →l06
13B	51119	1	18 mm 1 ring l→07
14A	51057	1	→l 06
14B	51115	1	l→07
15	83923	8	M12 x 20
16	83916	14	M10 x 16
17	83926	14	M10 x 19
18	24153	2	
19	83920	5	M10 x 20
20	83937	2	M12 x 30
21	83921	4	M10 x 25
22	83931	2	M16 x 30
24	25048	2	
25	81016	2	M10 x 16
26	11633	1	
27	24016	1	
28	85008	12	M8
29	84704	12	M18 x 16

**92105/2**

Afbeelding 9B : Snijstelsel vanaf serie 08

Abbildung 9B : Schneidvorrichtung ab Serie 08

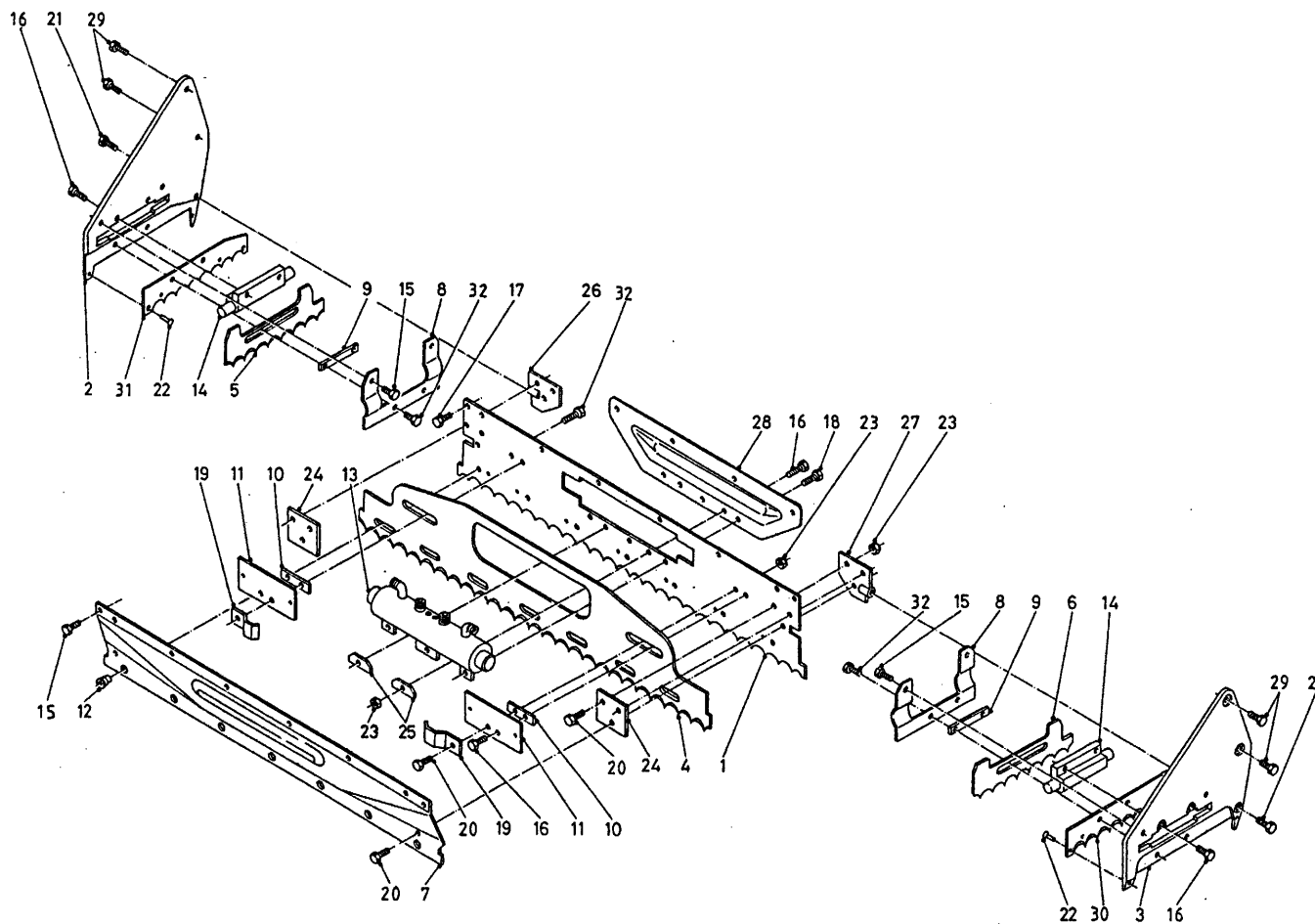

bestelnummer  
 ordernummer  
 num.à commander  
 Bestellnummer

1	23840	1	
2	12162	1	Rechts
3	12161	1	Links
4	25655	1	
5	25653	1	
6	25652	1	Rechts
7	26381	1	Links
8	23853	2	
9	25657	2	
10	23854	2	
11	23848	2	
12	31862	8	
13	51120	1	20 mm 2 ringen
14	51115	2	
15	84926	12	M10 x 19
16	83921	6	M10 x 25
17	83923	8	M12 x 20
18	83920	3	M10 x 20
19	24153	2	
20	83915	6	M10 x 30
21	83937	2	M12 x 30
22	85246	4	Ø5 x 20
23	86810	12	M10
24	26184	2	
25	25048	2	
26	12328	1	
27	12327	1	
28	26837	1	
29	83931	4	M16 x 30
30	26347	1	
31	26348	1	
32	83916	12	M10 x 16
33	11633	1	
34	24016	1	
35	85008	12	M8
36	84704	12	M8 x 16

**92105/2**

Afbeelding 10 : Slangenloop snijbord  
 Abbildung 10 : Schläuche Schneidschild

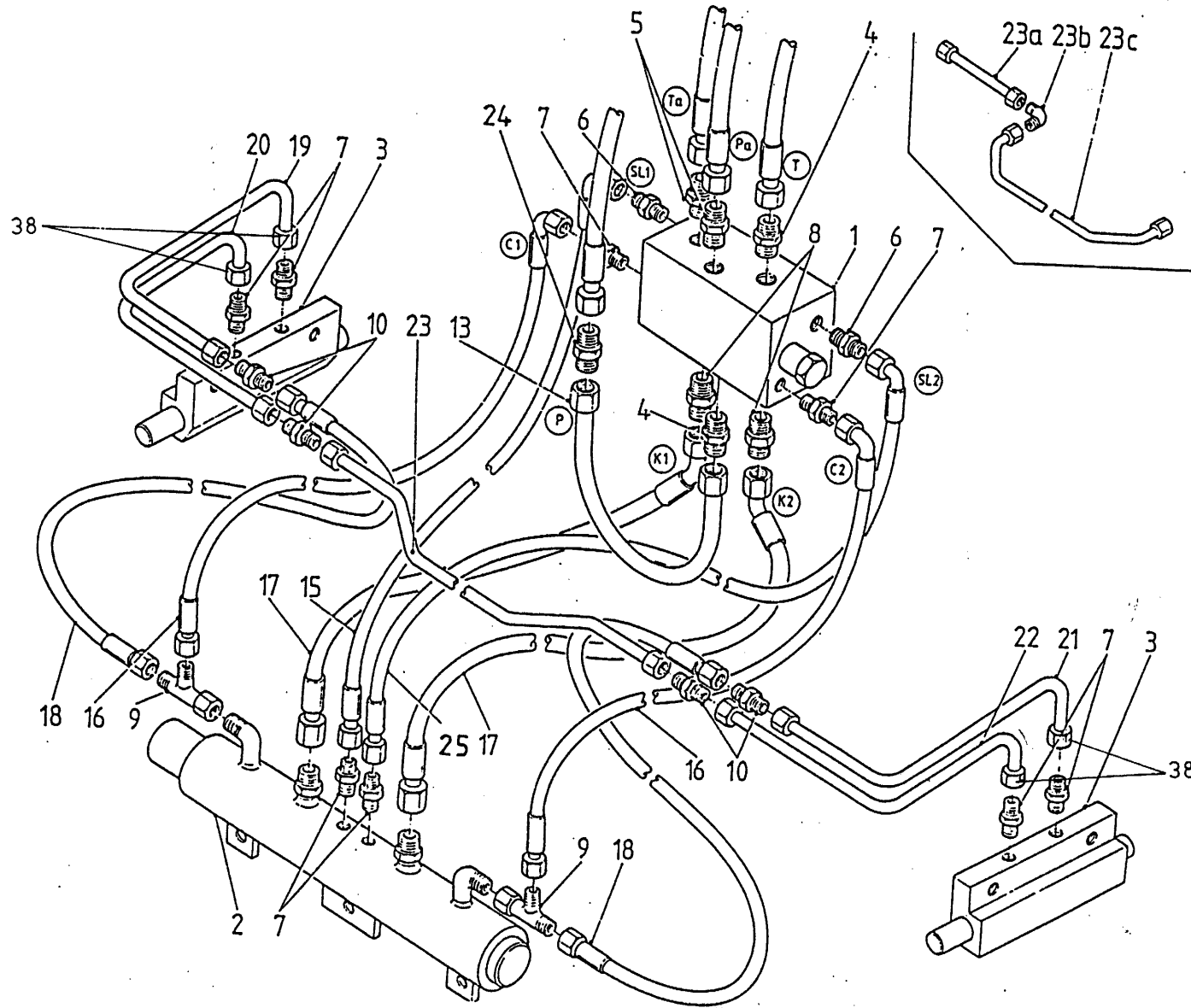

bestelnummer  
 ordernummer  
 num.à commander  
 Bestellnummer

1	53198	1	
2A	51061	1	18 mm → I 06 1 ring
2B	51120	2	20 mm → 07 2 ringen
3A	51057	2	→ I 06
3B	51115	2	→ 07
5	X50113	8	
6	X50114	4	
7	X50104	2	
8	X50102	4	
9	X50300	1	
10	X50135	2	
11	W50746	1	½" 850 R 45°
14	W50910	2	¾" 850 RR
15	W50971	2	¼" 400 H 20°
16	W50895	2	¼" 300 RH
17	W50970	1	½" 300 R 45°
18	W50896	1	¼" 460 RR
19	50876	1	
20	50875	1	
21	50878	1	
22	50877	1	
23	50890	1	
25	X50143	2	
26	W50827	2	½" 1200 RR
27	X50500	2	
28	X50502	2	
29	85219	2	
30	85008	2	M8
31	80816	1	M8 x 16
32	85230	1	
33	22907	1	
34	W50808	1	¾" 5200 RHZ
35	W50790	1	¾" 4500 RHZ
36	W50789	2	½" 5150 RR ¼"
37	W50972	1	¼" 400 H 20°
38	50430	4	

92105/2

Afbeelding 11 : Stuurblok inwendig  
 Abbildung 11 : Steuerblok Innenseite

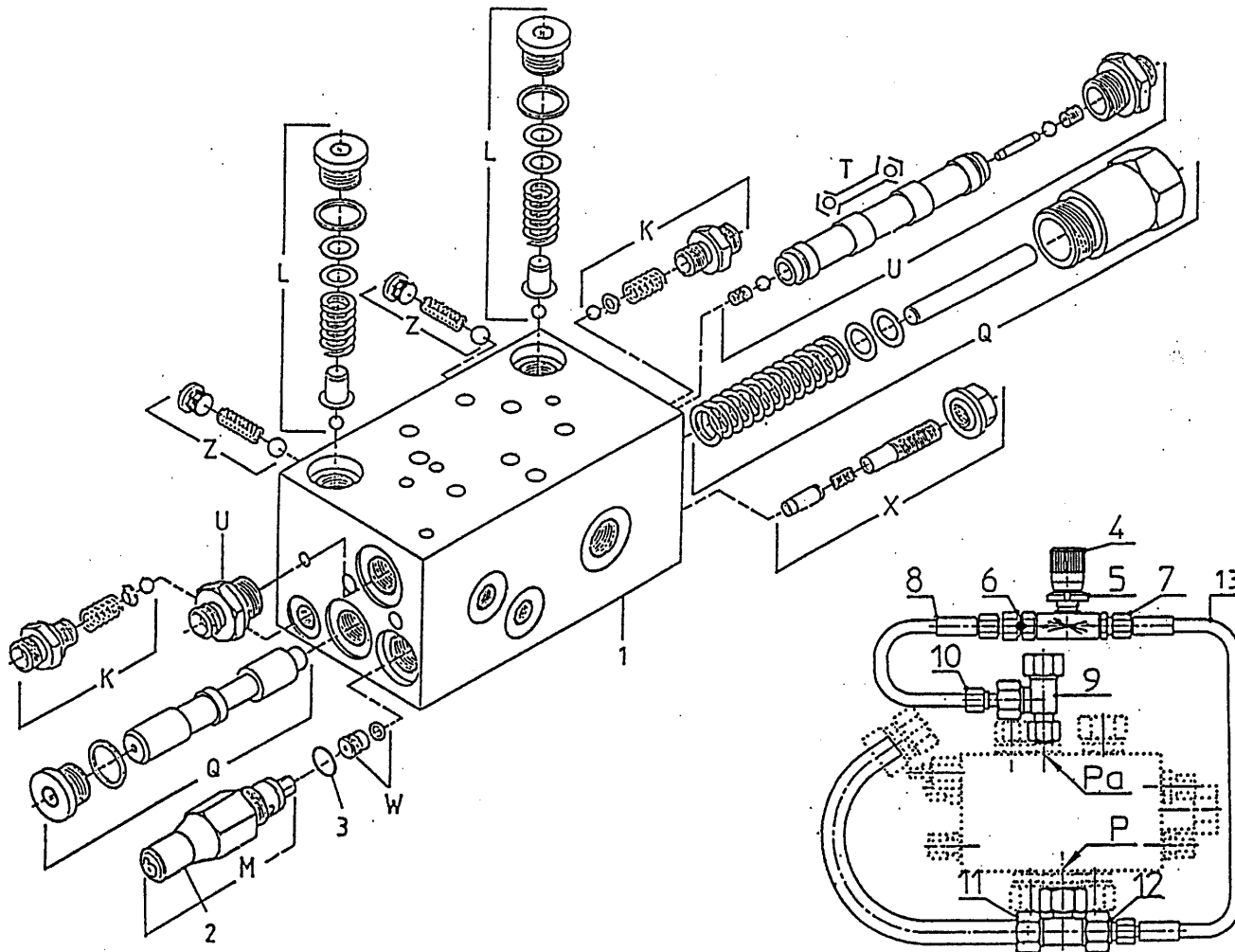

bestelnummer  
 ordernummer  
 Num. à commander  
 Bestellnummer

1	53198	1	
2	60260	1	
3	78053	1	12 x 1,5
4	53200	1	
5	86128	1	M20 x 1
6	53005	1	
7	X50201	1	
8	W50896	2	¼" 460 RR
9	X50309	1	
10	X50157	1	
11	X50312	1	
12	X50304	1	
13	W50719	1	¼" 900 RH
K	05049	2	10 bar
L	05264	2	200 bar
M	05265	1	
U	53150	1	
W	53256	1	
X	53257	7	

92105/2

Afbeelding 12 : Achter- en zijmescilinder

Abbildung 12 : Heck- und Seitenzylinder

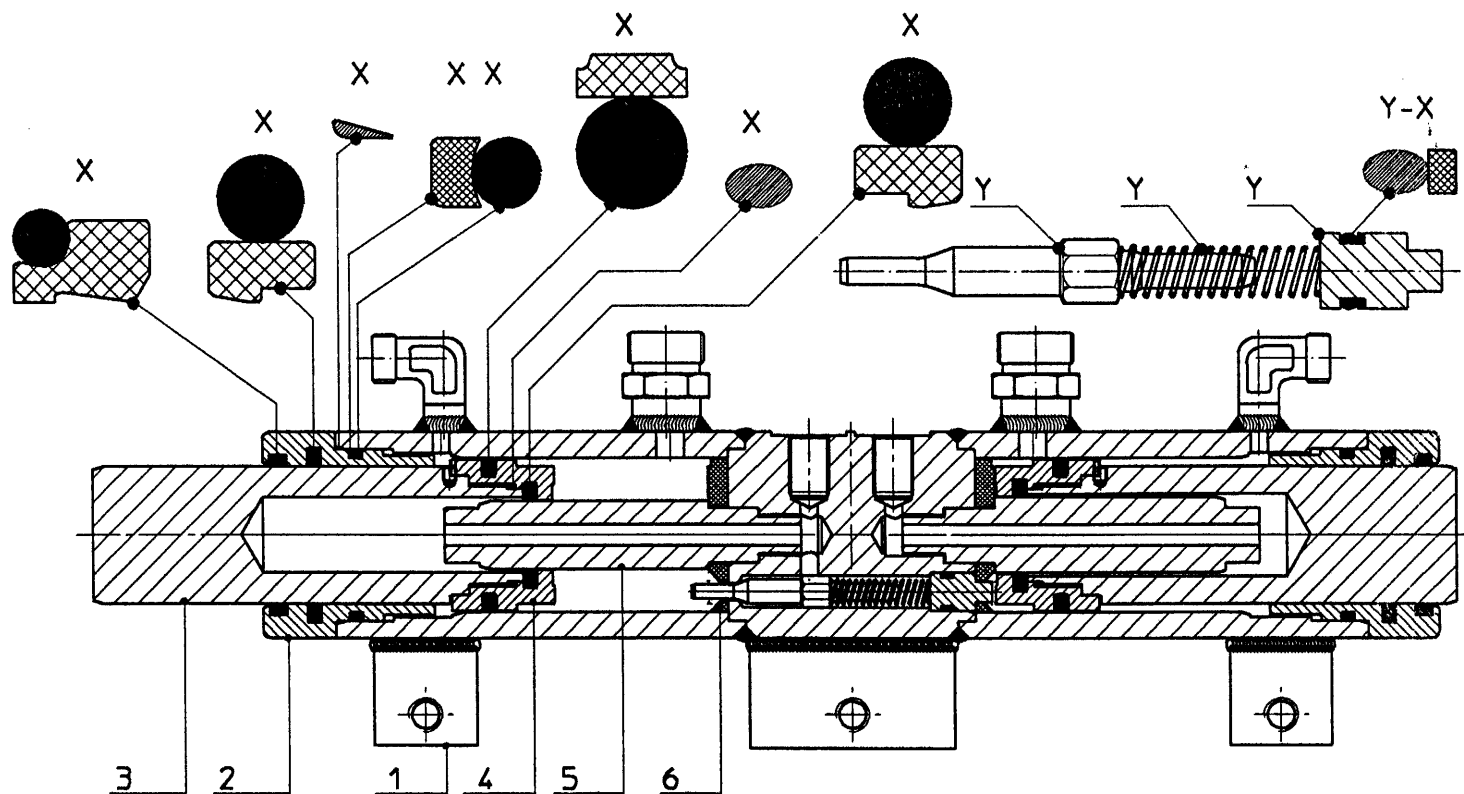

3 2 1 4 5 6

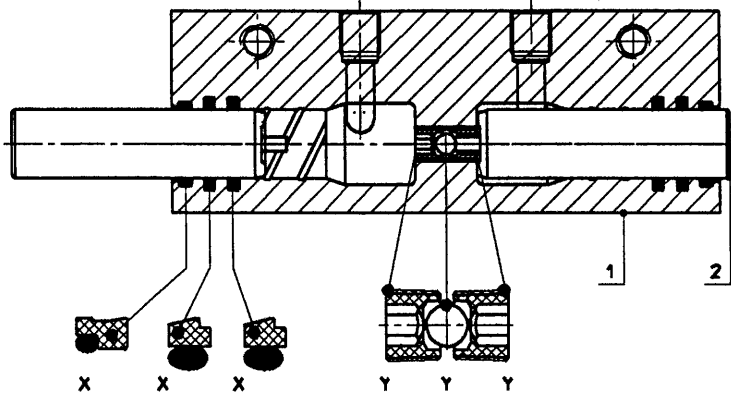

X X X Y Y Y

bestelnummer

ordernummer

Num. à commander

Bestellnummer

51119 / 51120

1	12106	1	
2	31421	2	
3A	31455	2	1 ring 51119
3B	31458	2	2 ringen 51120
4	31453	2	
5A	31454	2	18 mm 51119
5B	31457	2	20mm 51120
6	31428	2	
X	05306	1	
Y	05297	1	

51115

1	31772	1	
2	31436	2	
X	05294	1	
Y	05298	1	

**92105/2**

Afbeelding 13 : Mechanische afstandsbediening

Abbildung 13 : Mechanische Fernbedienung

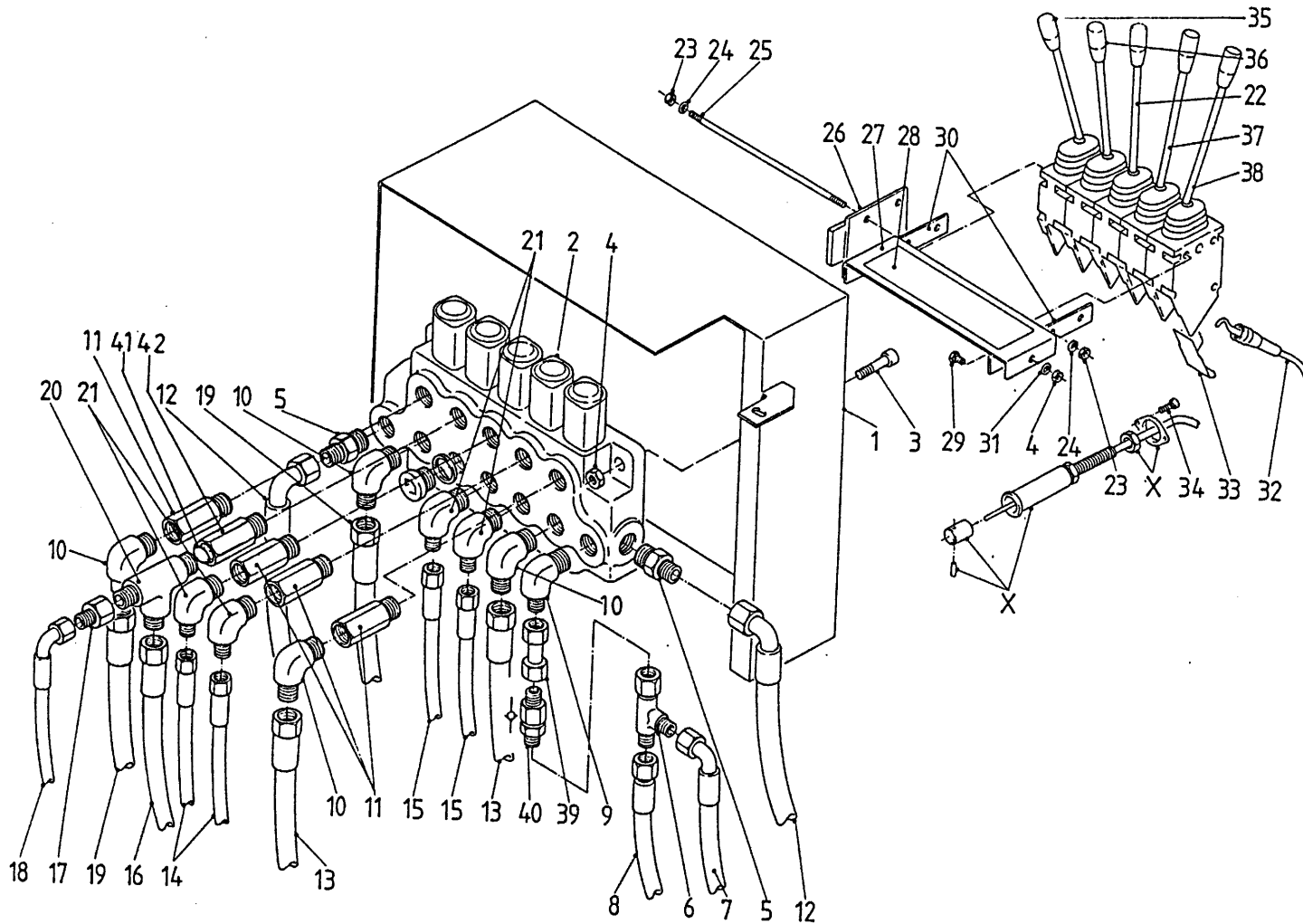

bestelnummer  
ordernummer  
num.à commander  
Bestellnummer

1	22056	1	
2	53137	1	
3	84419	3	M 8 x 45
4	86208	5	M 8
5	X50102	2	
6	50309	1	
7	W50785	1	3/8" 4500 RH
8	W50796	1	3/8" 5050 RR
9	50103	1	
10	X50101	4	
11	50133	4	
12	W50768	2	1/2" 3000 RH
13	W50793	2	1/2" 2100 RR
14	W50719	2	1/4" 900 RH
15	W50807	2	1/4" 1050 RH
16	W50794	1	3/8" 1000 RZ 45° Z
17	X50168	1	
18	W50787	1	1/4" 600 RZ HZ
19	W50789	2	1/2" 5150 RR
20	X50302	1	
21	X50118	4	
22	53099	1	
23	86206	6	M 6
24	85106	6	M 6
25	84159	3	M 6 x 240
26	11139	1	
27	22245	1	
28	91112	1	
29	80816	2	M 8 x 16
30	22244	2	
31	85108	2	M 8
32	79060	5	L = 3000
33	60210	5	
34	84426	10	M 6 x 16
35	53128	1	30° R
36	53127	1	15° R
37	53129	1	15° L
38	53130	1	30° L
39	50777	1	
40	53170	1	
41	53173	1	2 mm
42	31377	1	
X	05207	5	

**92105/1**

Afbeelding 14 : Elektrische bediening  
 Abbildung 14 : Elektrische Bedienung

bestelnummer  
 ordernummer  
 num.à commander  
 Bestellnummer

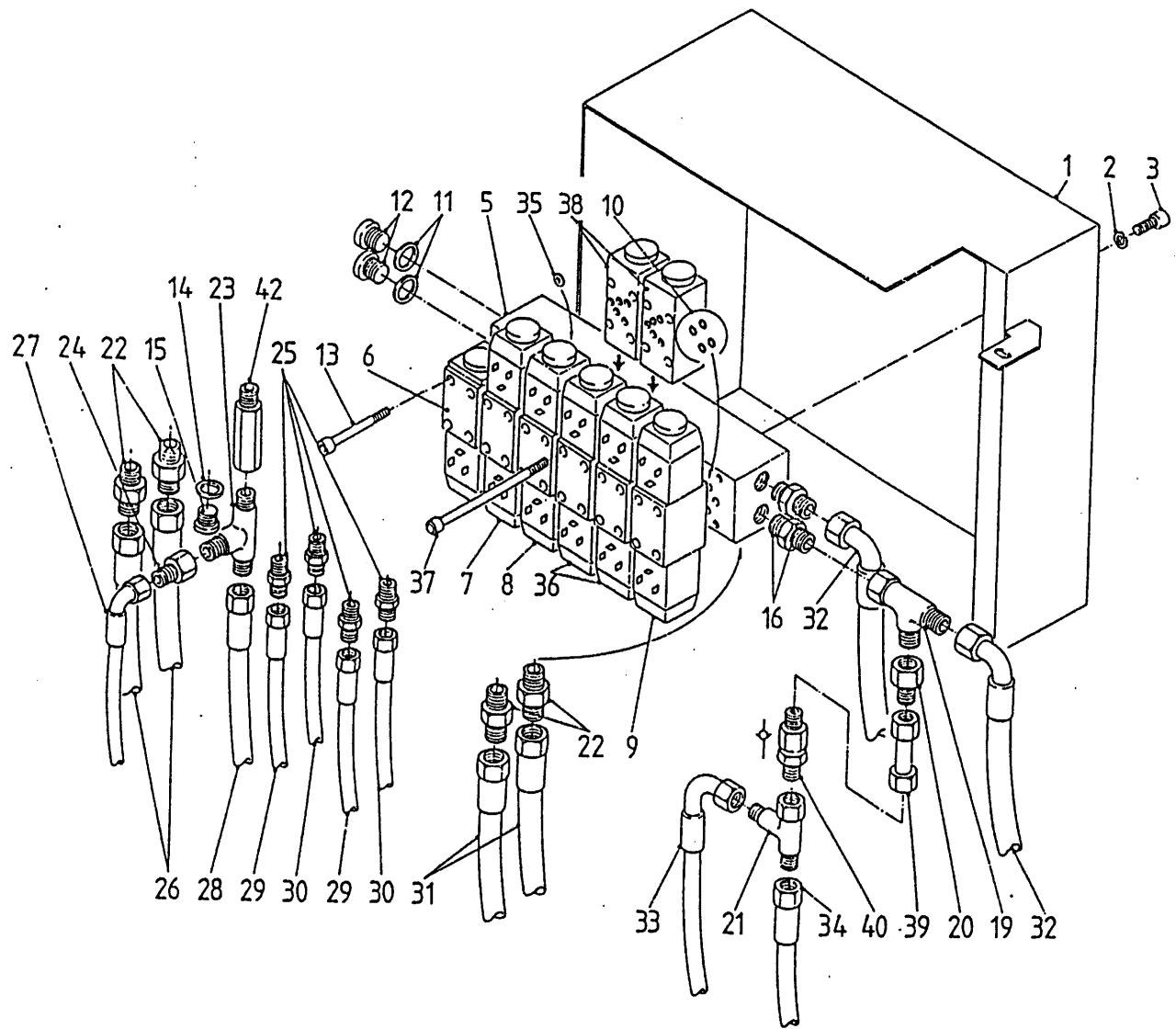

1	22056	1	
2	85008	4	M 8
3	84420	4	M 8 x 16
5	53067	1	
6	53080	1	
7	53105	1	
8	53079	3	
9	53104	1	
10	78057	24	
11	85225	2	
12	53316	2	
13	84433	24	M 5 x 30
14	85215	1	
15	53319	1	
16	X50142	2	
19	X50303	1	
20	50154	1	
22	X50102	4	
23	X50302	1	
24	X50168	1	
25	X50114	4	
26	W50789	2	½" 5150 RR
27	W50787	1	¼" 600 RZ HZ
28	W50794	1	⅜" 1000 RZ 45° Z
29	W50719	2	¼" 900 RH
30	W50807	2	¼" 1050 RR
31	W50793	2	½" 2100 RR
32	W50768	2	½" 3000 RH
33	W50785	1	⅜" 4500 RH
34	W50796	1	⅜" 5050 RR
35	31214	1	φ 2,6 mm
36	53135	2	
37	84438	8	M5 x 70
38	53149	2	
39	50777	1	
40	X53170	1	
41	X50359	1	
42	31377	1	
43	53173	1	φ 2 mm



92105/2

Afbeelding 15 : Bedieningskast en aansluitschema

Abbildung 15 : Bedienungspult und Schaltplan

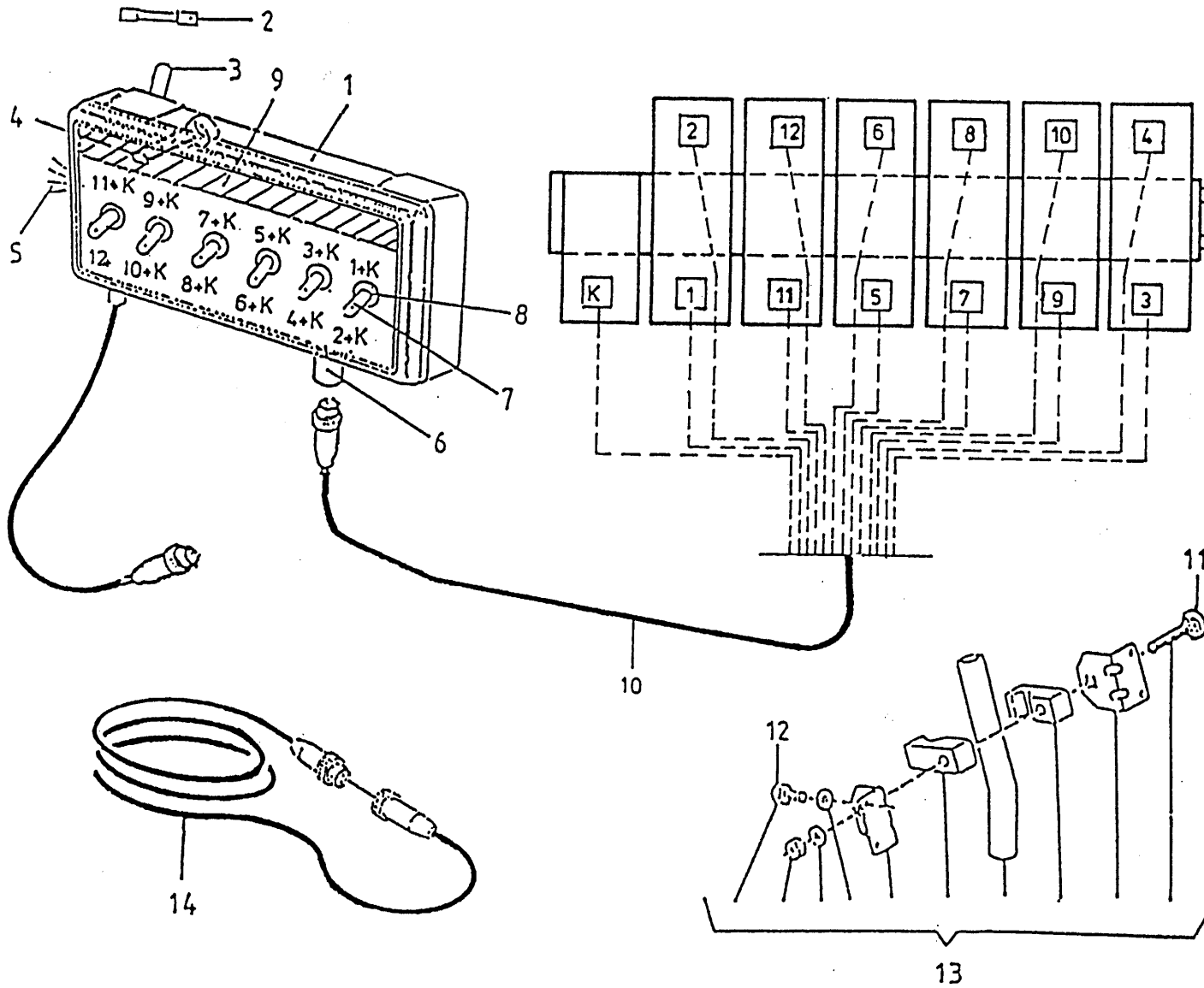

bestelnummer  
ordernummer  
num.à commander  
Bestellnummer

1	98073	1
2	98053	1
3	98054	1
4	98052	1
5	98051	1
6	98058	1
7	98056	5
8	98055	5
9	91015	1
10	98069	1
11	83150	1
12	84305	1
13	05154	1
14	98065	1

92105/2

Afbeelding 16 : Schakelcilinder en zijklepcilinder

Abbildung 16 : Schaltzylinder und Seitenklappezylinder

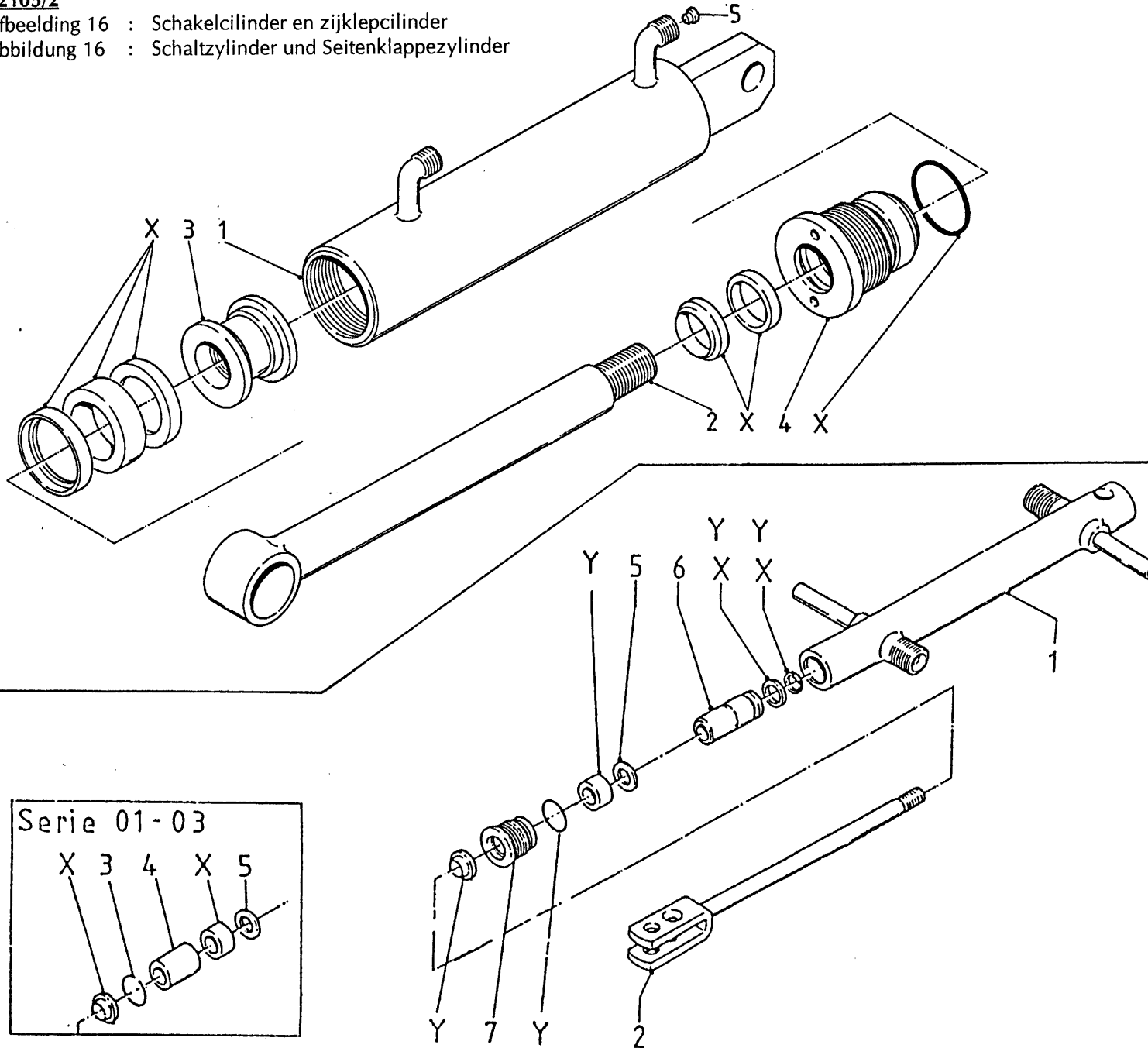

bestelnummer  
 ordernummer  
 num.à commander  
 Bestellnummer

50100

1	10969	1
2	11132	1
3	30860	1
4	30859	1
5	30726	1
X	05206	1

51012 / 51024 / 51055 / 51075 / 51098

1A	11410	1	Serie 01 75 mm
1B	11245	1	Serie 02 75 mm
1C	11546	1	Serie 03 85 mm
1D	11716	1	Serie 04 85 mm
1E	11879	1	↳ 05
2A	11246	1	Serie 01 + 02
2B	11545	1	↳ 03
3	85803	1	↳ 03
4	31099	1	↳ 03
5	31100	1	
6	31101	1	
7	31523	1	↳ 04
X	05218	1	
Y	05319	1	

92105/2

Afbeelding 17 : Cilinders teleskoop

Abbildung 17 : Zylinder Teleskop

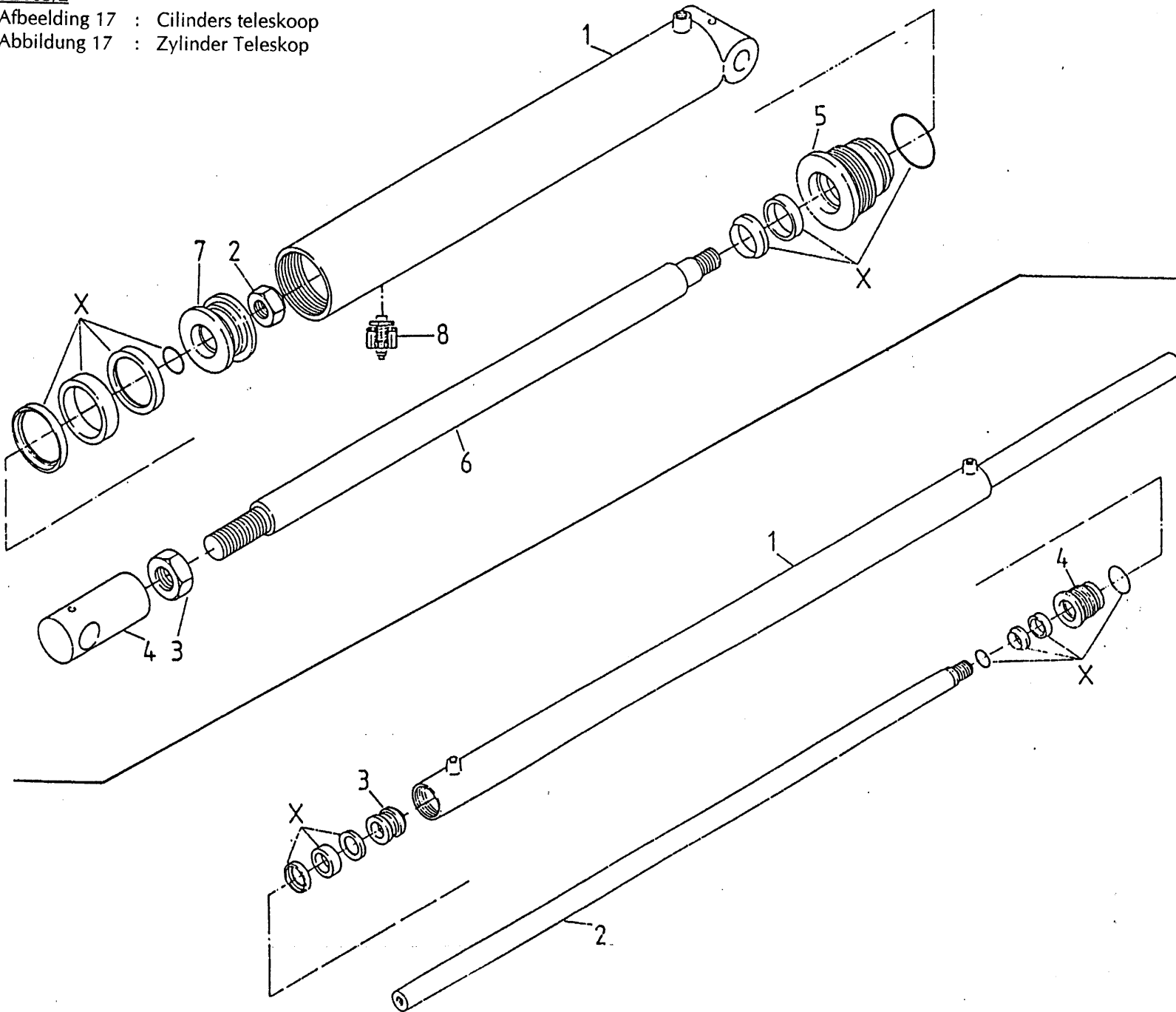

bestelnummer  
 ordernummer  
 num.à commander  
 Bestellnummer

51033/51067

1A	11218	1	→ I 02
1B	11464	1	I → 03
2	86227	1	
3	86920	1	
4	31001	1	
5	31085	1	
6	31086	1	
7	30911	1	
8	53187	1	0,8 mm
X	05209	1	

51005

1	11216	1	
2	31076	1	
3	31077	1	
4	31078	1	
X	05210	1	

92105/2

Afbeelding 18 : Dissel en wielarmcilinder

Abbildung 18 : Deichsel- und Radarmzylinder

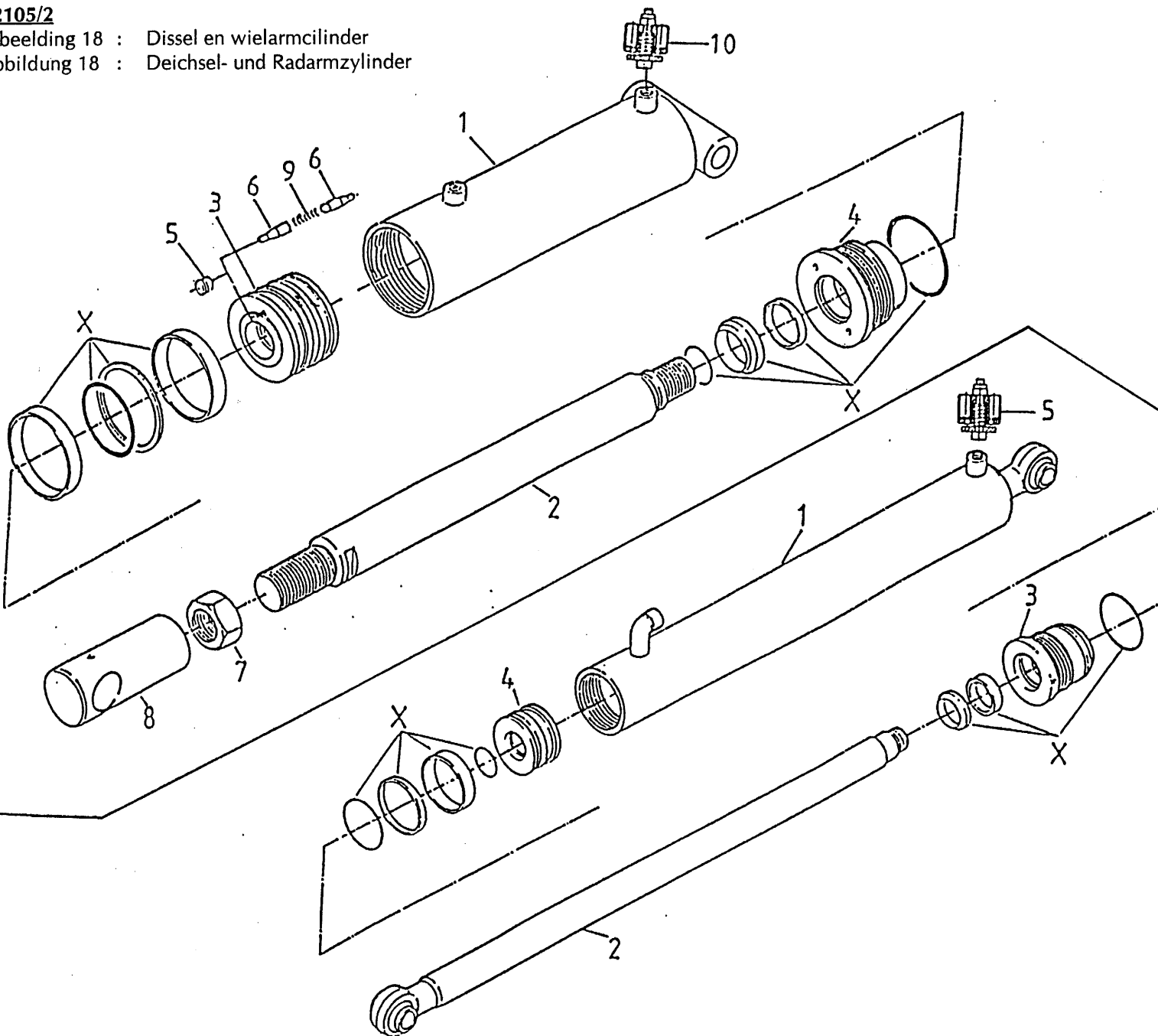

bestelnummer  
ordernummer  
num.à commander  
Bestellnummer

51006

1	11217	1	
2	31094	1	
3	31082	1	
4	31083	1	
5	30870	1	
6	31277	1	
7	86920	1	
8	31001	1	
9	65062	1	
10	53172	1	1,0 mm
X	05212	1	

51002/51066

1A	11171	1	serie 01 + 02
1B	11625	1	serie 03
2	11172	1	
3	30520	1	
4	31043	1	
5	53183	1	0,65 mm
X	05211	1	

92105/2

Afbeelding 19 : Aftakassen

Abbildung 19 : Gelenkwellen

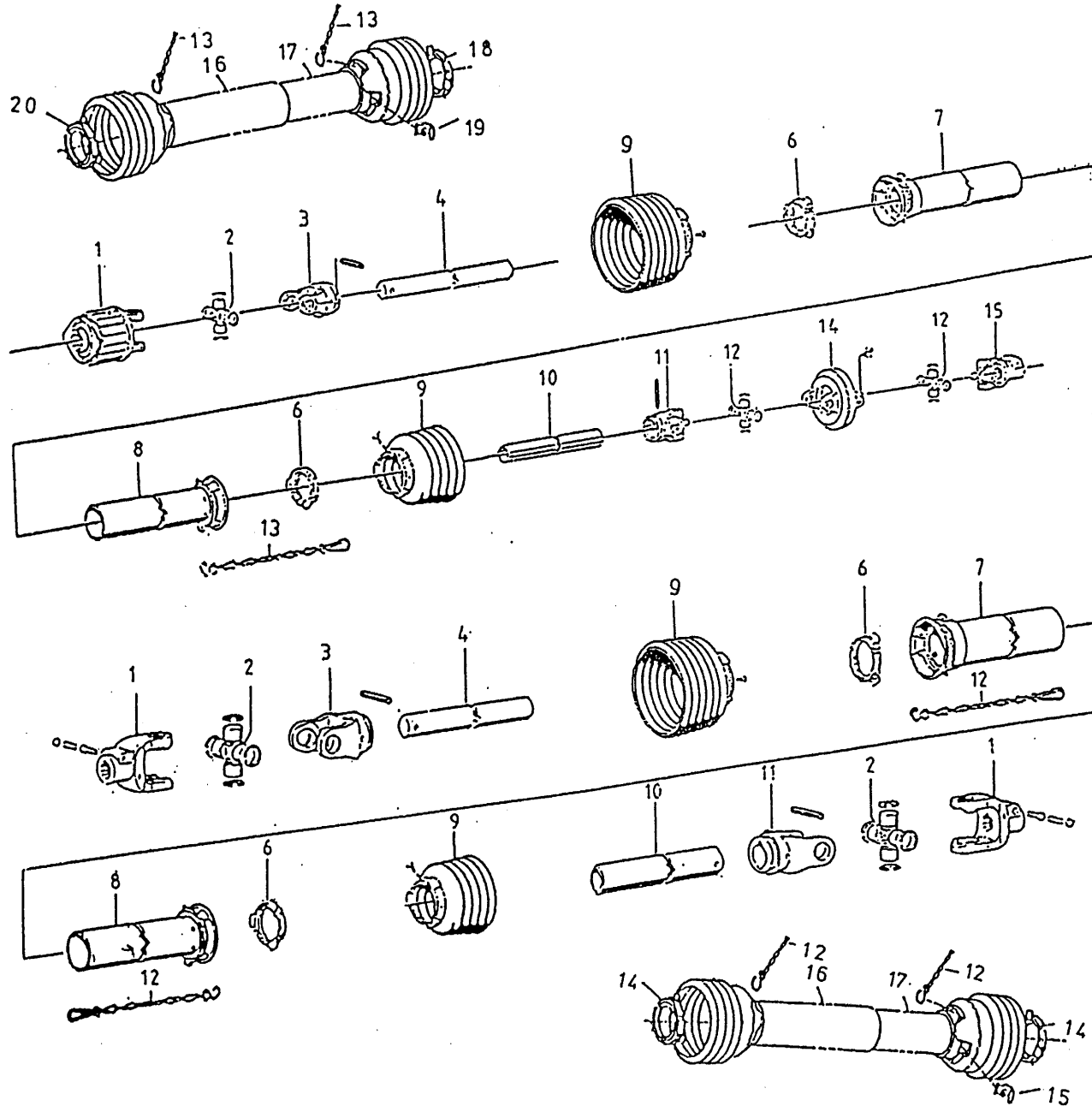

bestelnummer  
 ordernummer  
 num.à commander  
 Bestellnummer

90232

1	90237	1	
2	90249	1	
3	90238	1	
4	90239	1	
6	90241	2	→ 02
7	90242	1	→ 02
8	90243	1	→ 02
9	90245	2	→ 02
10	90246	1	
11	90251	2	
12	90252	2	
13	90266	2	
14	90254	1	
15	90272	1	
16	90355	1	→ 03
17	90351	1	→ 03
18	90357	1	→ 03
19	90349	2	→ 03
20	90361	1	→ 03

90233

1	90255	2	
2	90256	2	
3	90257	1	
4	90258	1	→ 02
6	90260	2	→ 02
7	90261	1	→ 02
8	90262	1	→ 02
9	90263	2	
10	90264	1	
11	90265	1	
12	90266	2	→ 03
14	90358	2	→ 03
15	90349	2	→ 03
16	90359	1	→ 03
17	90360	1	

92105/2

Afbeelding 20 : Electronisch weegsysteem

Abbildung 20 : Electronische Waage

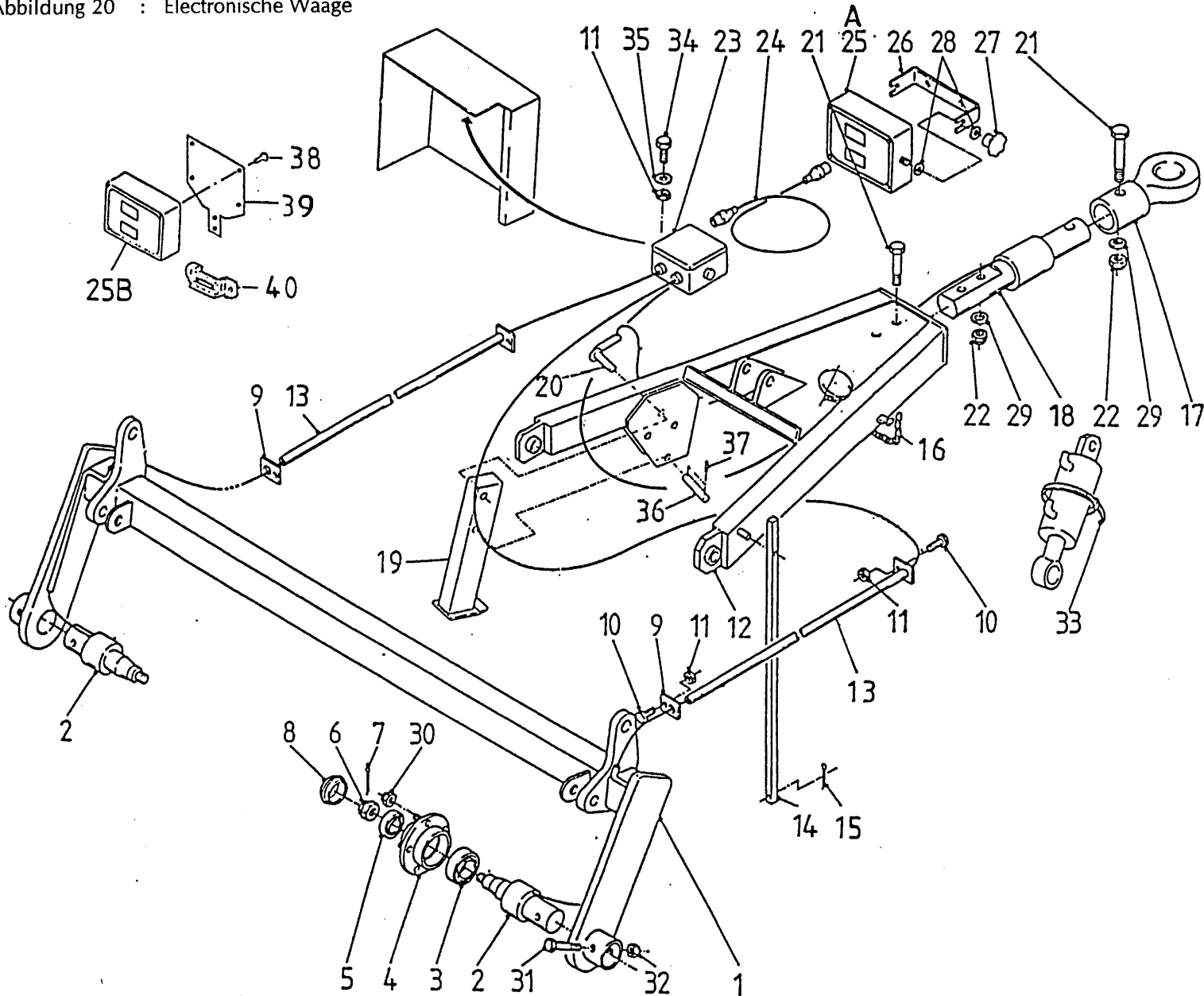

bestelnummer  
ordernummer  
Num. à commander  
Bestellnummer

1A	11547	1	22,5 mm → I 05
1B	11811	1	0 mm I → 06
2A	90299	1	Links
2B	90353	1	Rechts
3	70057	2	
4	90308	2	
5	70056	2	
6	90223	2	
7	90224	2	
8	90225	2	
9	23623	2	
10	80825	4	M8 x 25
11	86208	5	M8
12	11272	1	
13	11436	2	
14	22953	1	
15	88242	1	Ø 3,5 x 30
16	39136	1	
17	11355	1	
18	90276	1	
19	11735	1	
20	11736	1	
21	82010	3	M20 x 100
22	86220	3	M20
23	98075	1	
24	98076	1	
25A	90300	1	→ I 06
25B	90539	1	I → 07
26	23633	1	
27	60024	2	
28	60022	4	
29	85120	3	M20
30	86922	12	M18
31	81610	2	M16 x 100
32	86216	2	M16
33	90109	24	
34	80820	2	M8 x 20
35	85108	2	M8
36	31548	1	
37	88030	1	Ø 6 x 30
38	81016	4	M10 x 16
39	40475	1	
40	20199	1	

92105/2

Afbeelding 21 : Hydraulisch schema mechanische bediening

Abbildung 21 : Hydraulischer Schaltplan mechanische Fernbediening

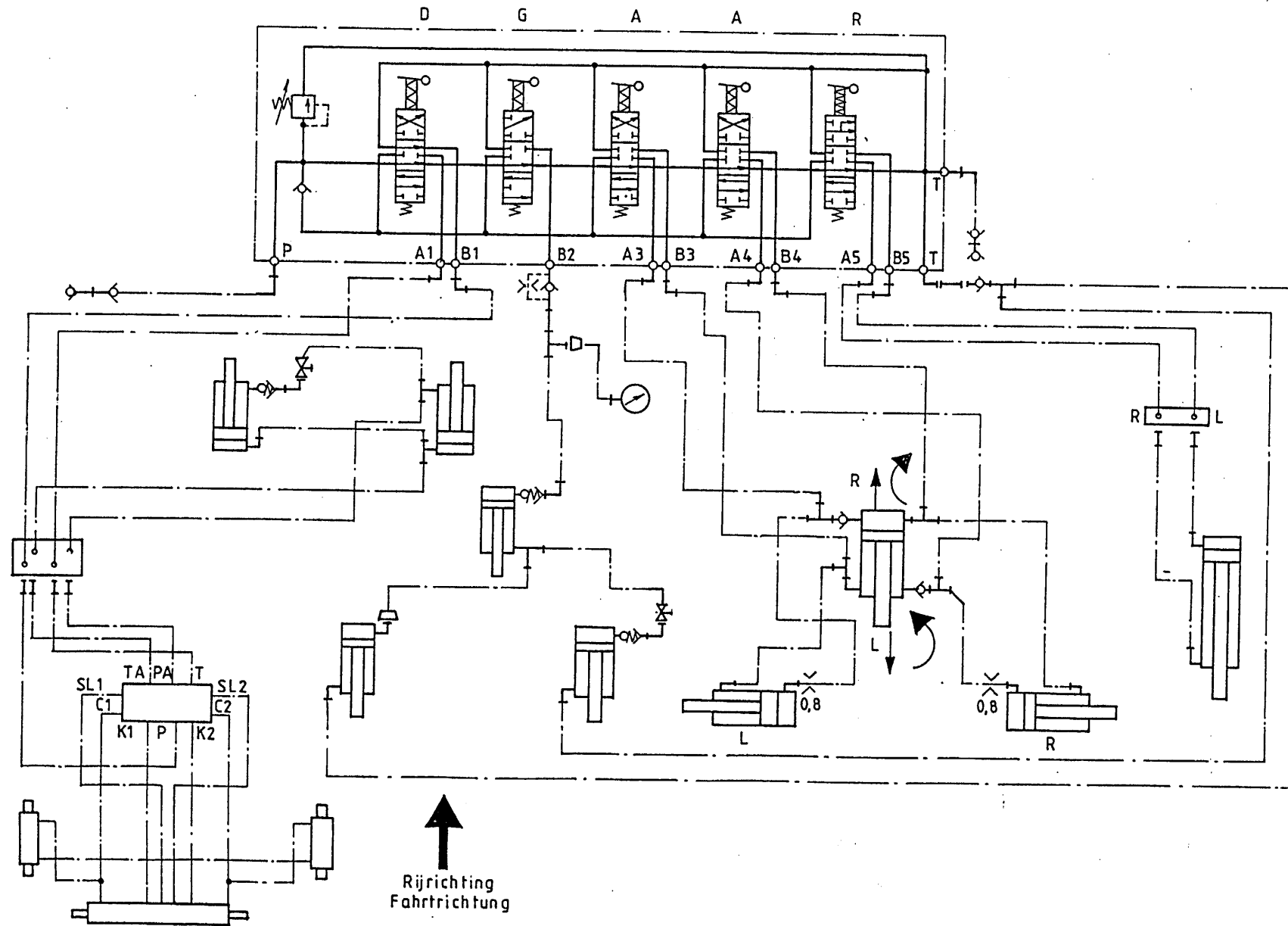

92105/2

Afbeelding 22 : Hydraulisch schema elektrische bediening

Abbildung 22 : Hydraulischer Schaltplan elektrische Fernbedienung

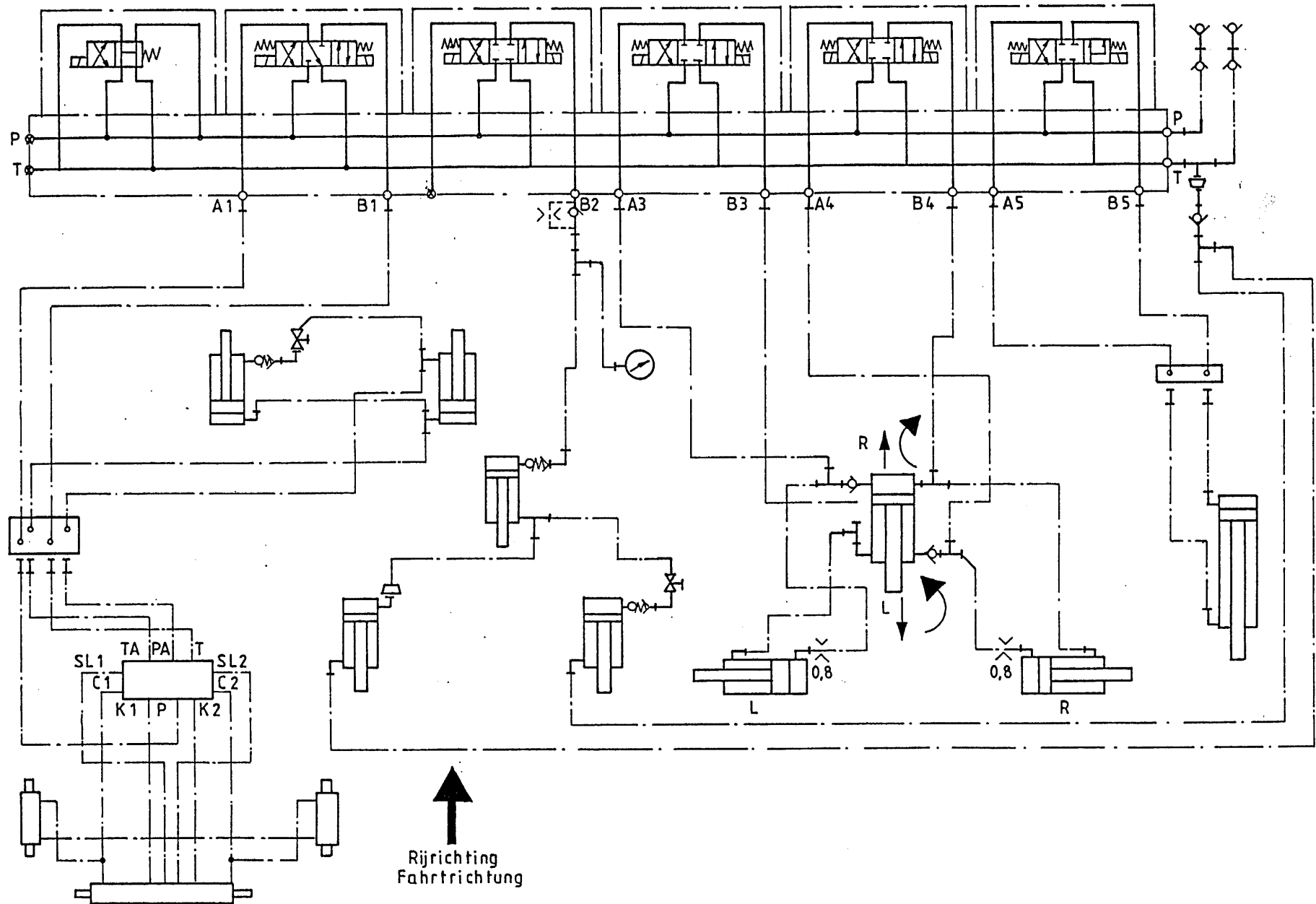



92015/2

Afbeelding 23 : Elektrisch schema

Abbildung 23 : Elektrischer Schaltplan

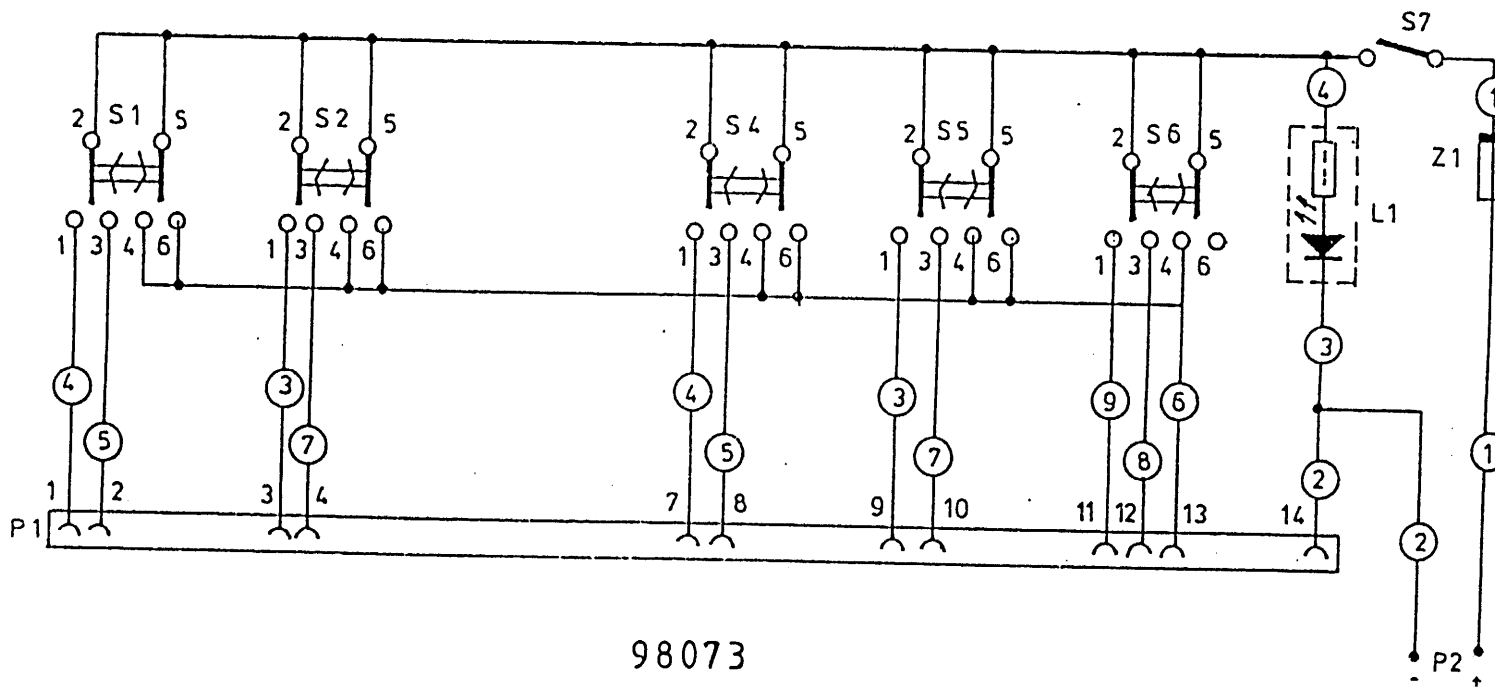

98073

	Kleurcodering	Farbenschlüssel	Colour code	Codes des couleurs
1	Bruin	Braun	Brown	Brun
2	Blauw	Blau	Blue	Bleu
3	Geel	Gelb	Yellow	Jaune
4	Rood	Rot	Red	Rouge
5	Oranje	Orange	Orange	Orange
6	Paars	Violet	Purple	Violet
7	Groen	Grün	Green	Vert
8	Wit	Weiß	White	Blanc
9	Grijs	Grau	Grey	Gris

Afbeelding 1



Himmanweg 19

7575 BE Oldenzaal - Holland

Postbus 134

7570 AC Oldenzaal - Holland

e-mail: [info@triolet.nl](mailto:info@triolet.nl)

<http://www.triolet.nl>

Tel.: 0541 - 57 21 21 / (+) 31 - 541 - 57 21 21

Fax: 0541 - 57 21 25 / (+) 31 - 541 - 57 21 25

Voor onderdelen / Für Ersatzteile:

Tel.: 0541 - 57 21 36 / (+) 31 - 541 - 57 21 36

Fax: 0541 - 57 21 40 / (+) 31 - 541 - 57 21 40