

TRIO LIET

Trio liet

*Uitkuildosemengwagen
Siloentnahmемenschwagen*

MULTIMIX

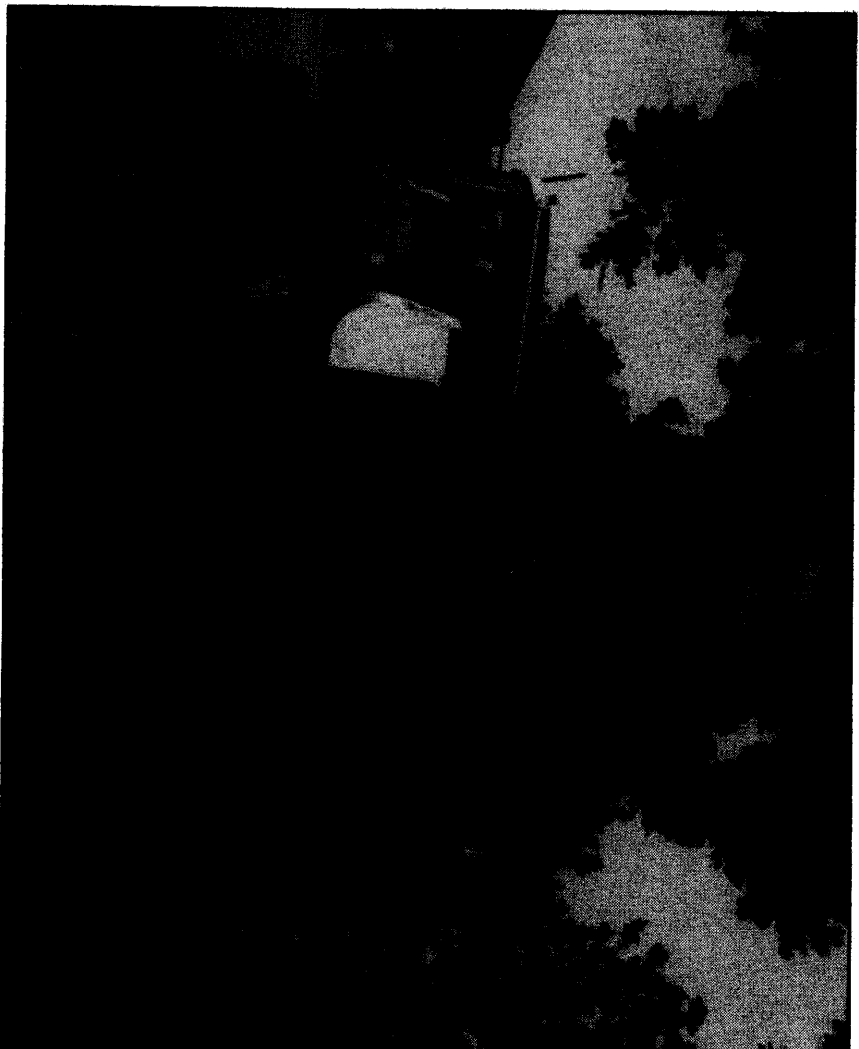

*Onderdelen- en Werkplaatshandboek
Ersatzteilliste und Werkstatthandbuch*

Bestelnummer / Bestellnummer 92105/1

Geldig vanaf productieserie nr. / Gültig ab Prod. Series No.: 04

INHOUDSOPGAVE:

Afb.

1. Stickers
Aufkleber
2. Frame
Rahmen
3. Dissel
Deichsel
4. Wielstel
Radachse
5. Mengkettinaandrijving
Mischkettenantrieb
6. Aandrijving
Antrieb
7. Tandwielkasten
Getriebe
8. Teleskoop
Teleskoparm
9. Snijsteeem
Schneidvorrichtung
10. Slangenloop snijbord
Schläuche Schneidschild
11. Stuurblok inwendig
Steuerblock (innenseite)
12. Achter- en zijcilinder
Hinter - und Seitenmesserzylinder
13. Mechanische afstandsbediening
Mechanische Fernbedienung
14. Elektrische bediening
Elektrische Bedienung
15. Bedieningskast en aansluitschema
Bedienungspult und Schaltplan

16. Schakelcilinder en zijklepcilinder
Schaltcilinder und Seitenklappecilinder
17. Cilinders teleskoop
Zylinder Teleskop
18. Dissel- en wielarmcilinder
Deichsel- und Radarmcilinder
19. Aftakassen
Gelenkwellen
20. Elektronisch weegstelsel
Elektronische Waage
21. Hydraulisch schema mechanische bediening
Hydraulischer Schaltplan mechanische Fernbedienung
22. Hydraulisch schema elektrische bediening
Hydraulischer Schaltplan elektrische Fernbedienung
23. Elektrisch schema
Elektrischer Schaltplan

92105/1

Afbeelding 1 : Stickers
 Abbildung 1 : Aufkleber

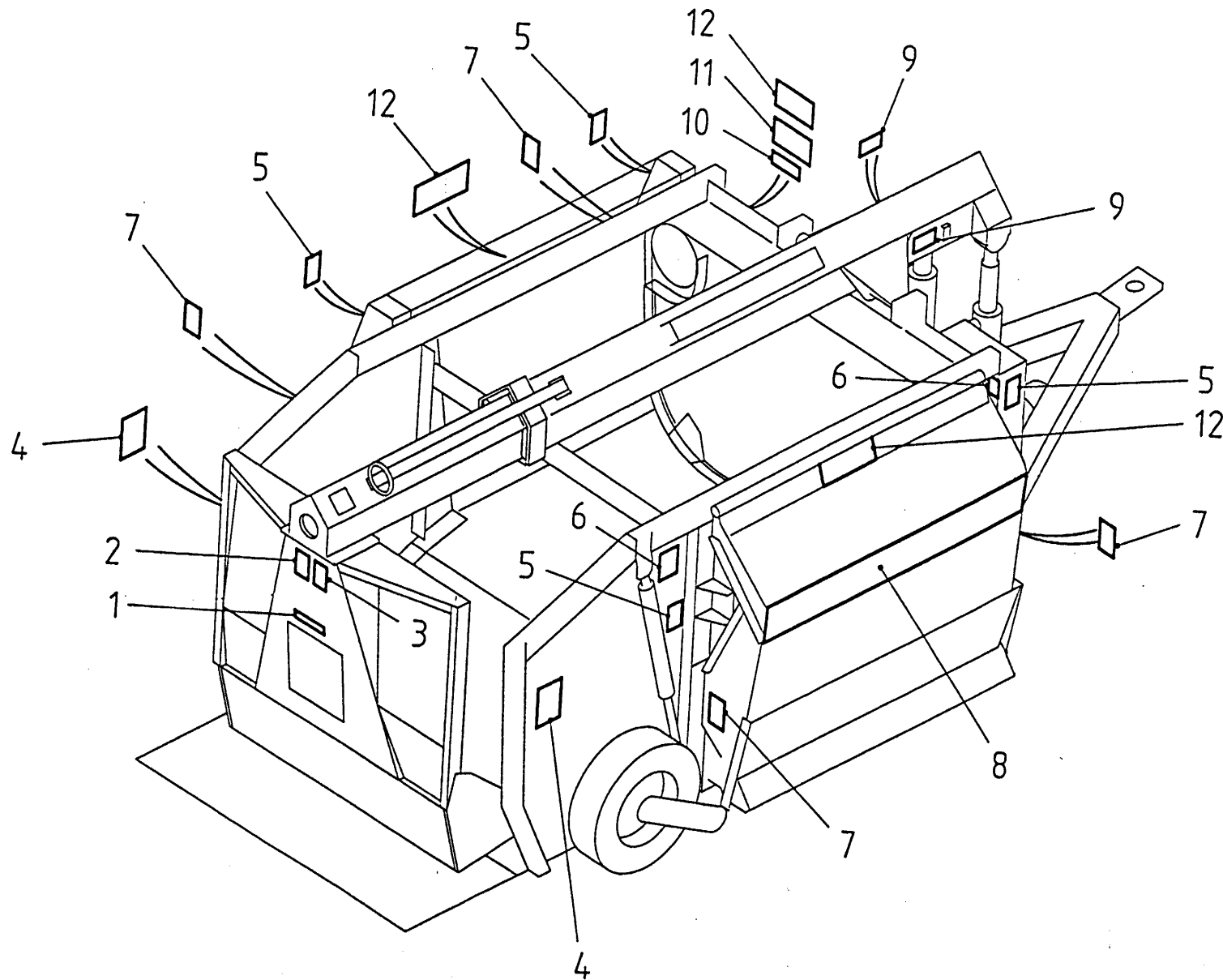

bestelnummer
 ordernummer
 num.à commander
 Bestellnummer

1	91002	1	
2	91153	1	
3	91163	1	
4	91172	2	
5	91152	4	
6	91128	2	
7	91180	4	
8	91178	2	
9	91151	2	
10	91159	1	
11	91160	1	
12	91164	3	
13	91185	1	
14	91190	1	
15	91182	2	
16	91183	4	
17	91189	1	
18	91118	2	

92105/1

Afbeelding 2 : Frame

Abbildung 2 : Rahmen

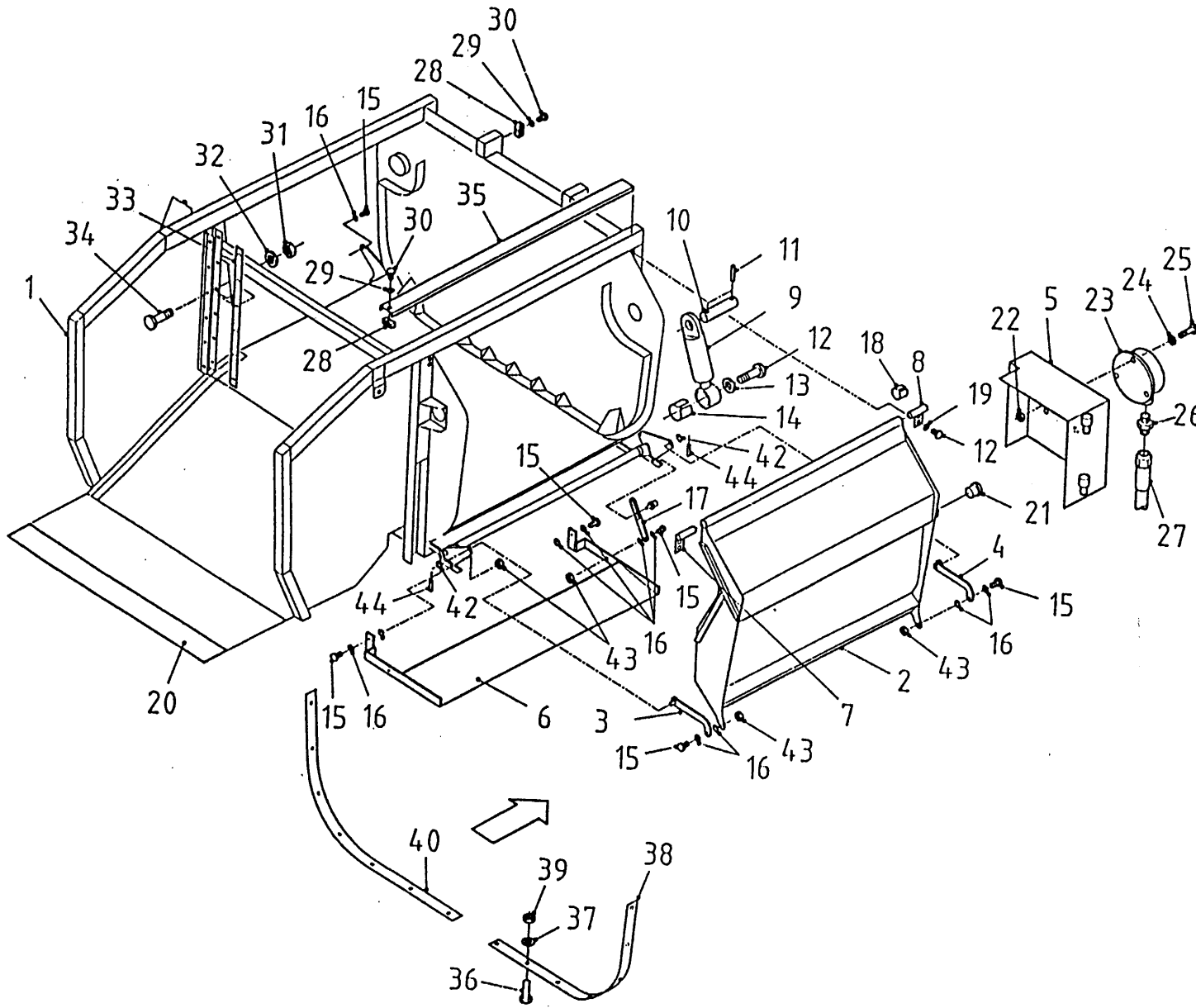

bestelnummer
ordernummer
Num. à commander
Bestellnummer

1	11208	1	
2	11207	1	
3A	11261	2	→ I 05
3B	11740	2	↳ 06
4A	11262	2	→ I 05
4B	11739	2	↳ 06
5	22056	1	
6	11180	2	
7	11188	2	
8	11183	2	
9	50100	2	
10	31379	2	
11	88029	4	∅ 4 x 30
12	81226	10	M12 x 25
13	85115	2	M12
14	51797	2	
15A	84919	16	M12 → I 05
15B	81651	10	M16 x 50 ↳
16A	85121	16	M12 → I 05
16B	85116	20	M16 ↳ 06
17	22807	2	
18	51805	4	
19	85112	8	M12
20	23225	1	
21	60228	4	
22	86205	3	M5
23	53197	1	
24	85105	3	M5
25	80516	3	M5 x 16
26	X50415	1	
27	W50787	1	¼" 600 RZHZ
28	90159	4	
29	85108	4	M8
30	84401	4	M8 x 40
31	86208	10	M8
32	85108	10	M8
33	60206	2	
34	80826	10	M8 x 25
35	40300	1	

92105/1

Afbeelding 2 : Frame

Abbildung 2 : Rahmen

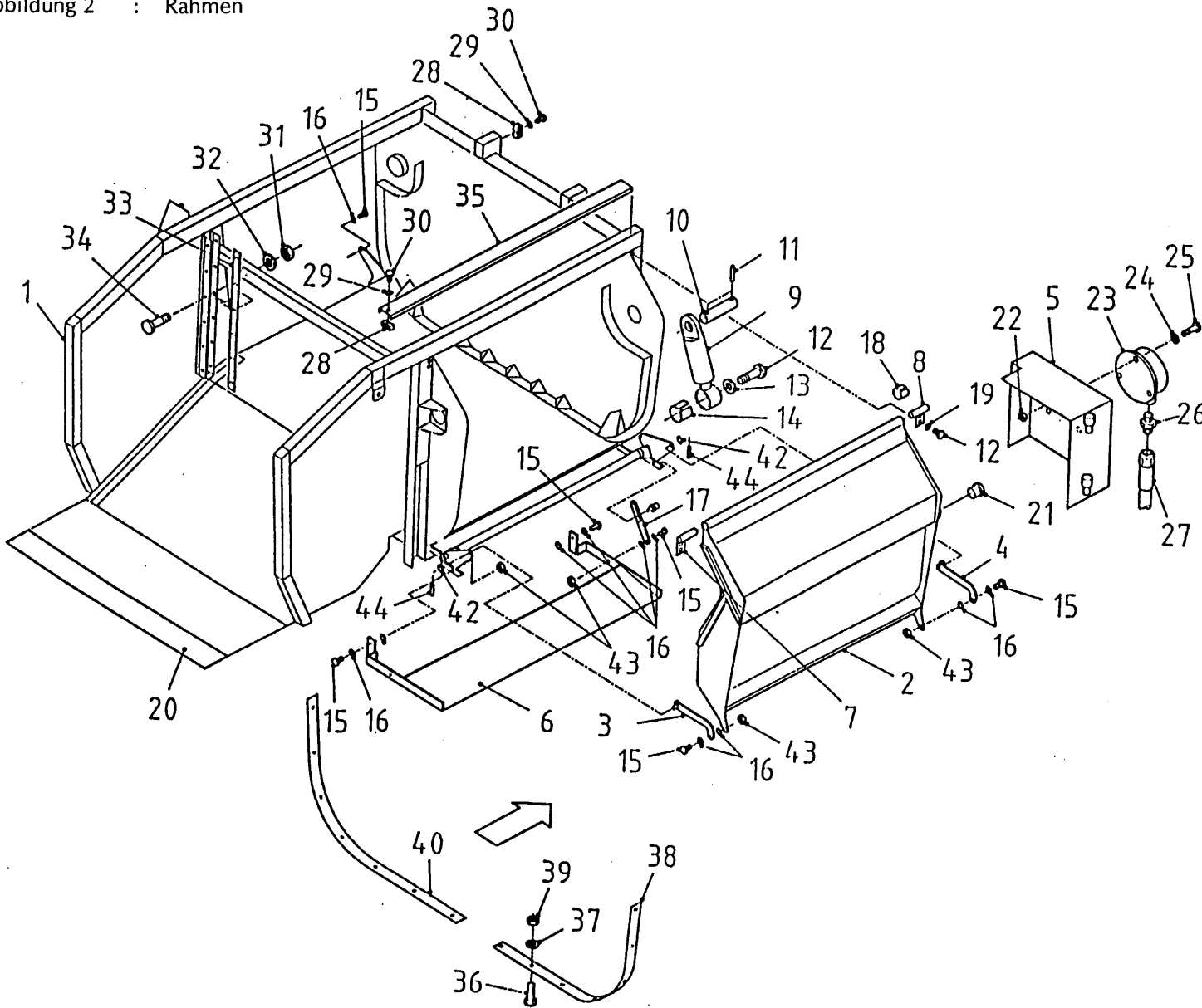

bestelnummer
ordernummer
Num. à commander
Bestellnummer

36	84194	32	M6 x 40
37	85406	32	M6
38	60227	2	Rechts
39	86606	32	M6
40	60226	2	Links
42	85116	6	M16 → 06
43	86216	26	M16 → 06
44	88027	6	∅ 6 x 26 → 06

92105/1

Afbeelding 3 : Dissel

Abbildung 3 : Deichsel

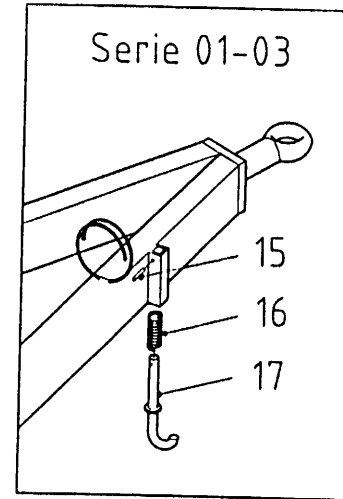
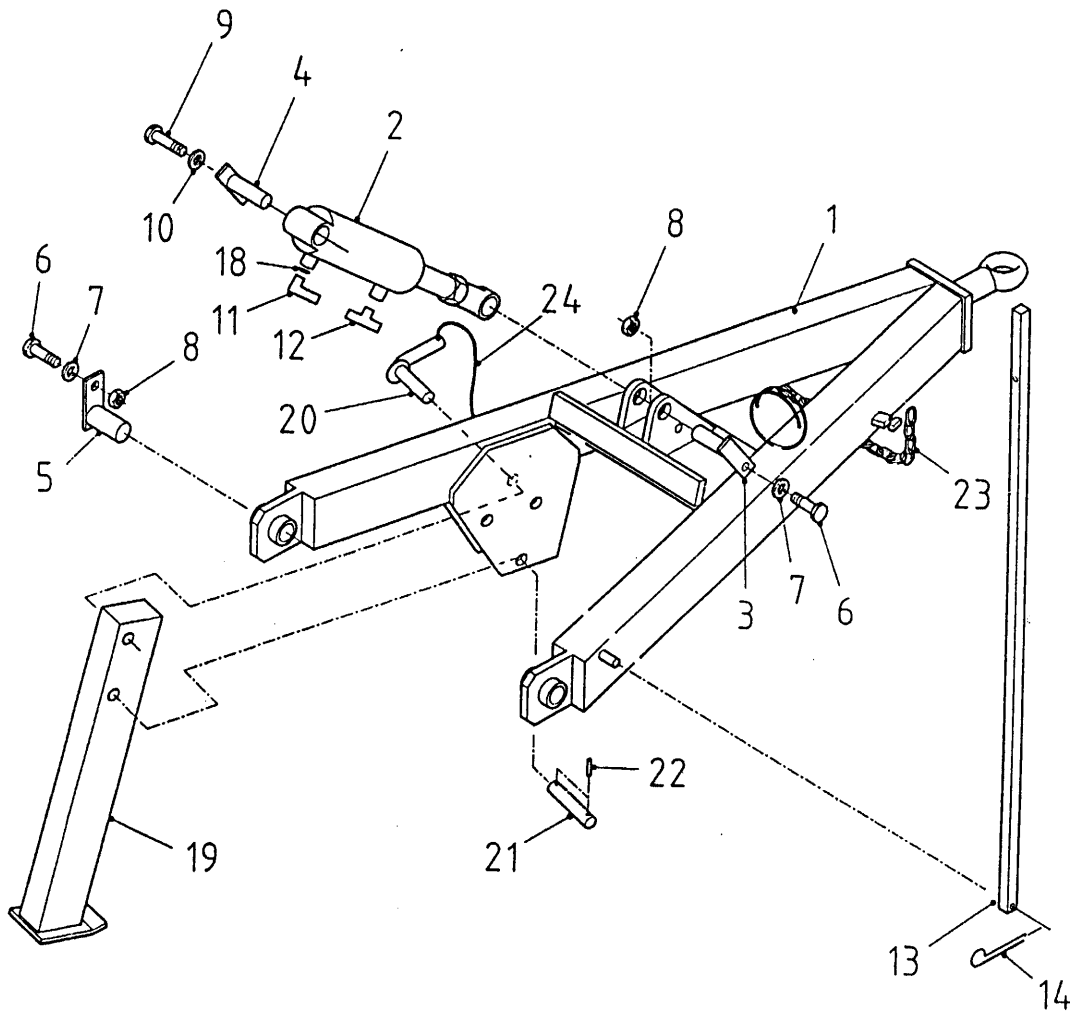

bestelnummer
ordernummer
Num. à commander
Bestellnummer

1	11233	1	
2	51006	1	
3	11223	1	
4	11225	1	
5	11215	2	
6	81035	3	M10 x 35
7	85110	3	M10
8	86210	3	M10
9	81031	1	M10 x30
10	85010	1	M10
11	X5010	1	
12	X5035	1	
13	22953	1	
14	88242	1	Ø 3,5 x 40
15	88028	1	Ø 5 x 28 → I 03
16	65061	1	→ I 03
17	11439	1	→ I 03
18	53172	1	Ø 1 mm
19	11735	1	→ 04
20	11736	1	→ 04
21	31548	1	→ 04
22	88030	2	Ø 6 x 30 I → 04
23	39136	1	→ 04
24	90282	1	→ 04

92105/2

Afbeelding 4 : Wielset

Abbildung 4 : Radachse

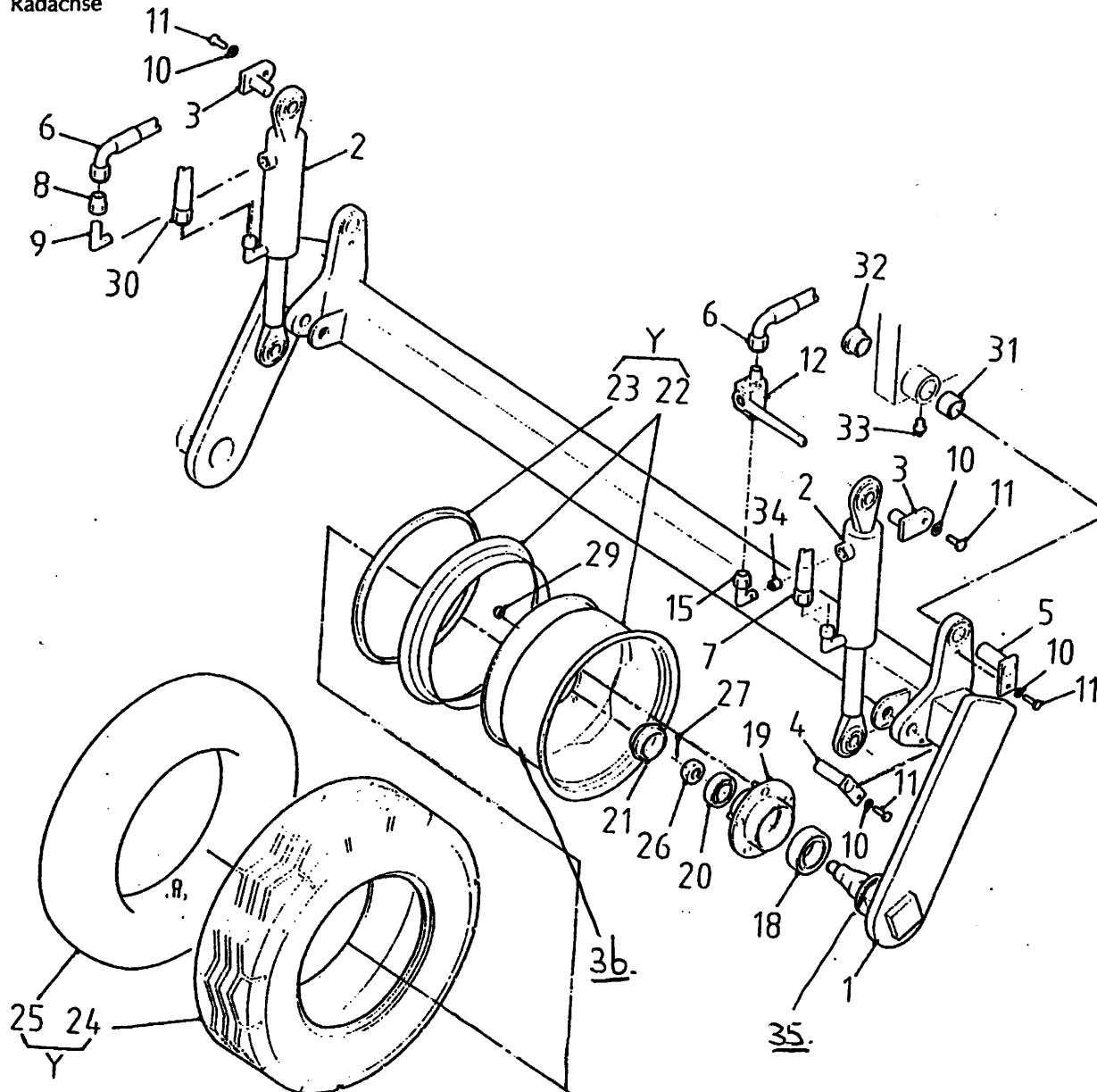

bestelnummer
ordernummer
num.à commander
Bestellnummer

1A	11548	1	21,5 mm → I 05
1B	11812	1	0 mm I → 06
2A	51002	2	→ I 02
2B	51066	2	I → 03
3	11532	2	
4	11198	2	
5	11204	2	
6	W50795	2	3/8" 3550 RHZ
7	W50785	1	3/8" 4500 RH
8	X50154	1	
9	X50101	1	
10	85008	6	M 8
11	80821	6	M 8 x 20
12	51023	1	
15	50103	1	
18	70057	2	
19	90308	2	
20	70056	2	
21	90225	2	
22A	90288	2	21,5 mm → I 05
22B	90408	2	0 mm I → 06
23	90292	2	
24	90290	2	
25	90291	2	
26	90223	2	
27	90224	2	
29	86922	12	M18 x 1,5
30	W50796	1	3/8" 5050 RR
31	51843	2	
32	51747	2	
33	89503	2	
34	53183	1	0,65 mm
Y1	90289	2	21,5 mm → I 05
Y2	90407	2	0 mm I → 06
35	90399		
36	90752		

92105/1

Afbeelding 5 : Mengkettingaandrijving
 Abbildung 5 : Mengkettenantrieb

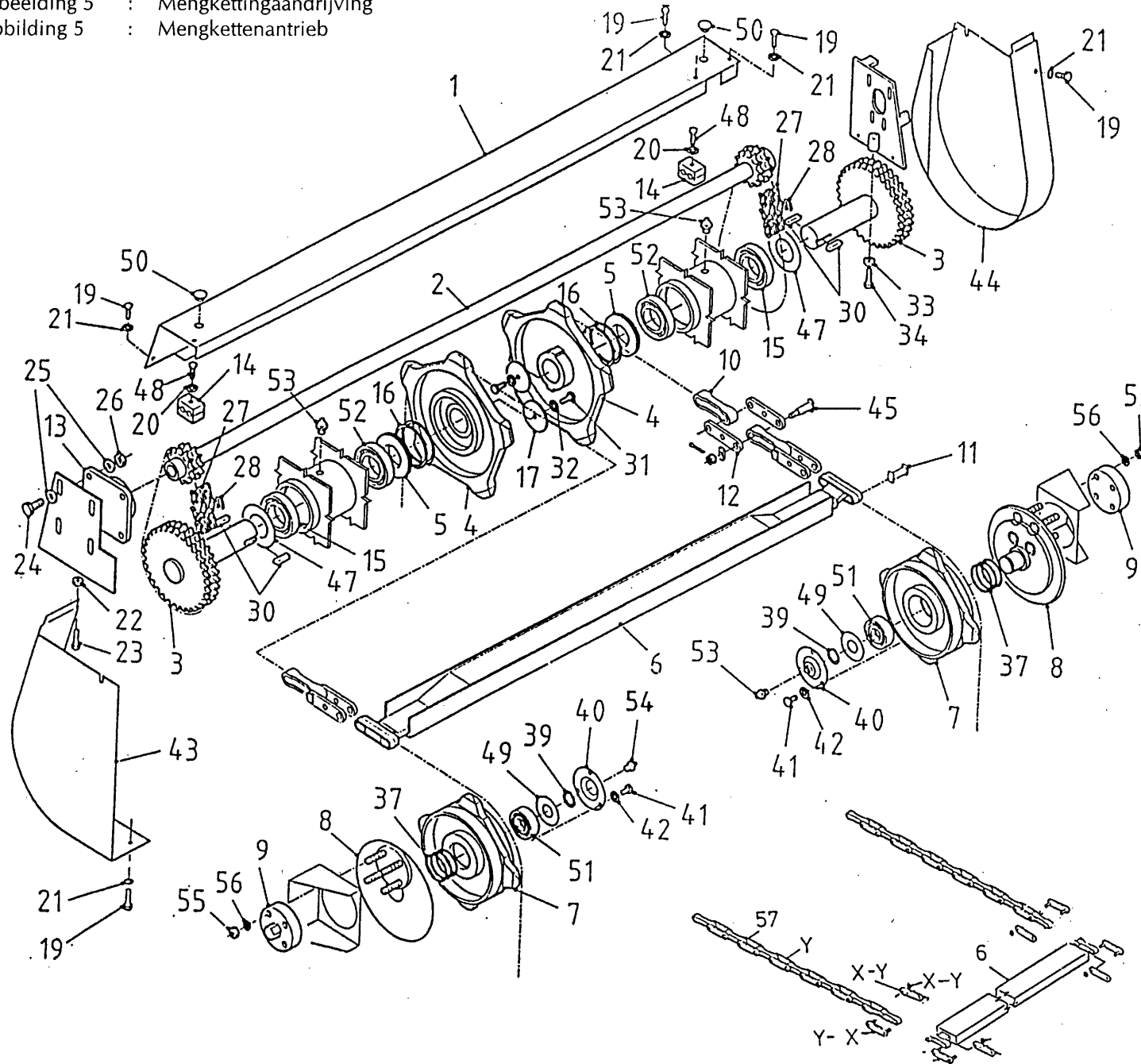

bestelnummer
 ordernummer
 Num. à commander
 Bestellnummer

1	40318	1	
2	11331	1	
3	11330	2	
4	39109	2	
5	31093	2	
6A	11336	5	→ I 03
6B	11749	5	→ 04
7	39110	2	
8A	11344	2	e=40 → I 03
8B	11666	2	e=70 → 04
9A	10807	2	→ I 03
9B	11667	2	→ 04
10	39101	48	→ I 05
11	39102	114	→ I 05
12	39100	116	→ I 05
13	70081	1	
14	90159	1	
15	70079	2	6212 2RS
16	70080	2	
17	22608	2	
19	80612	11	M6 x 12
20	85108	2	M8
21	85106	11	M6
22	86112	1	M12
23	81239	1	M12 x 140
24	81241	4	M12 x 40
26	86212	4	M12
27	39098	2	
28	39099	2	
30	88337	4	18 x 11 x 40
31	81025	2	M10 x 25
32	85110	2	M10
33	86116	1	M16
34	81690	1	M16 x 90
37	70072	2	
39	87035	2	
40	24414	2	

92105/1

Afbeelding 5 : Mengkettingaandrijving

Abbildung 5 : Mengkettenantrieb

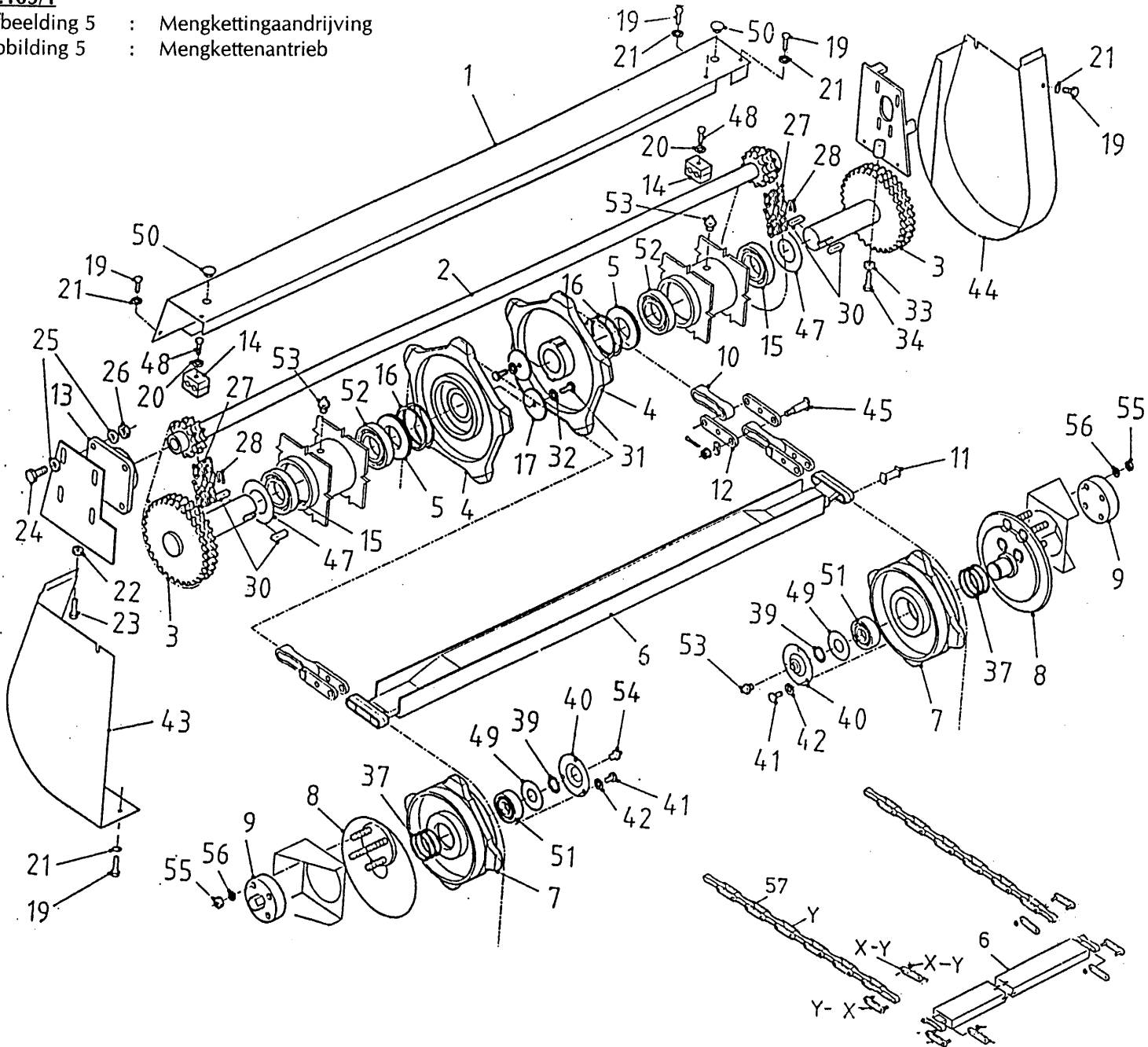

bestelnummer
 ordernummer
 Num. à commander
 Bestellnummer

41	80612	6	M6 x 12
42	85106	6	M6
43	11337	1	
44	11340	1	
45	39106	2	→ I 05
47	85360	2	
48	84401	2	M8 x 40
49	85335	2	
50	90315	2	
51A	70075	2	→ I 02 3207
51B	70095	2	→ I 03 3207 Z
52	70097	2	6212Z
53	89503	2	M6
54	89519	2	M8
55	86216	8	M16
56	85116	8	M16
57A	39167	2	L = 714,7
57B	39168	8	L = 918,9
X	39165	20	
Y	05367	1	

92105/1

Afbeelding 6 : Aandrijving

Abbildung 6 : Antrieb

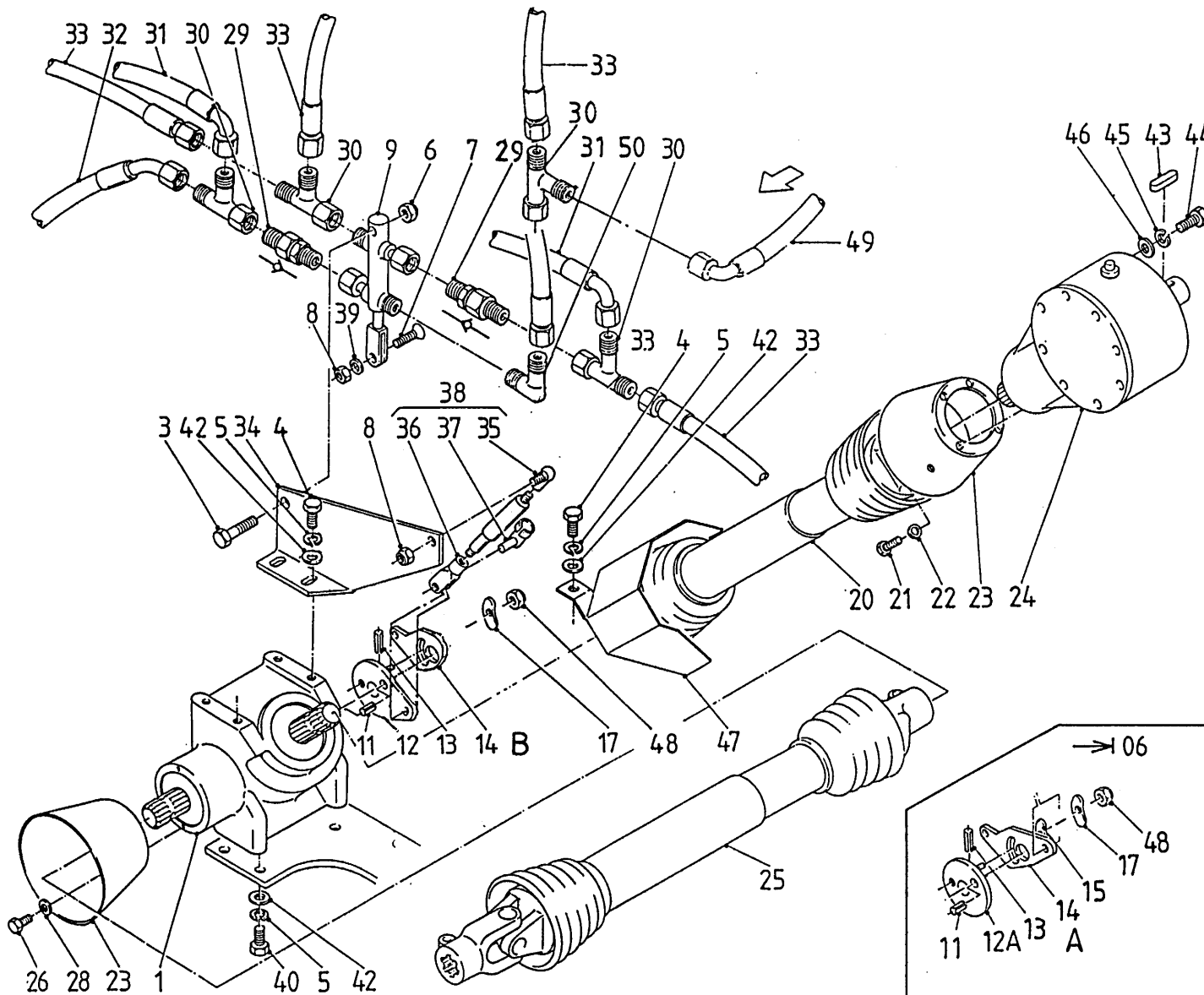

bestelnummer
ordernummer
Num. à commander
Bestellnummer

1	90226	1	
3	81045	1	M10 x 45
4	81226	5	M12 x 25
5	85012	7	M12
6	86210	1	M10
7	84183	1	M8 x 30
8	86208	1	M8
9A	51024	1	→102 75 mm
9B	51098	1	→03 85 mm
11	88015	1	Ø 8 x 16
12A	11543	1	→106
12B	12030	1	→07
13	88030	1	Ø 6 x 30
14A	24547	1	→106
14B	25578	1	→07
15	60211	1	→106
17	11845	1	
20	90233	1	
21	81016	2	M10 x 16
22	85113	2	M10
23	90284	2	
24	90227	1	
25	90232	1	
26	80816	2	M8 x 16
28	85109	2	M8
29	X53018	2	
30	X50300	4	
31	W50719	2	¼" 900 RH
32	W50806	3	¼" 950 R45°
33	W50807	4	¼" 1050 RR
34	11544	1	
35	70092	1	
36	31293	1	
37	31675	1	
38	90316	1	
39	85108	1	M8

92105/1

Afbeelding 6 : Aandrijving

Abbildung 6 : Antrieb

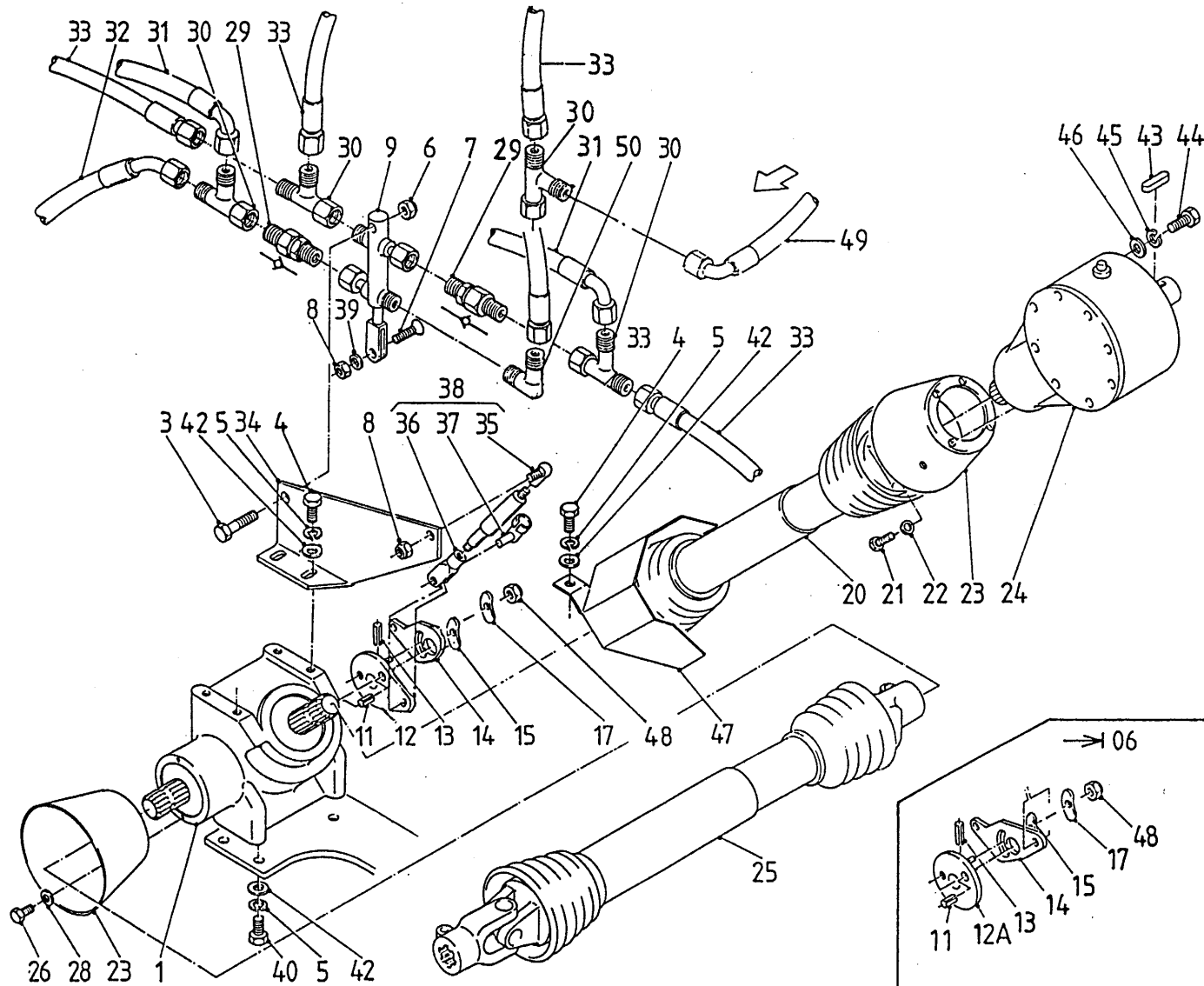

bestelnummer
 ordernummer
 Num. à commander
 Bestellnummer

40	81236	4	M12 x 35
41	85012	9	M12
42	85112	9	M12
43	88358	1	14 x 9 x 61
44	81641	4	M16 x 40
45	85016	4	M16
46	85116	4	M16
47	11557	1	
48	86212	1	M12
49	W50743	1	¼" 1200 RH
50	50107	1	
51	65070	1	

92105/1

Afbeelding 7 : Tandwielkasten

Abbildung 7 : Getriebe

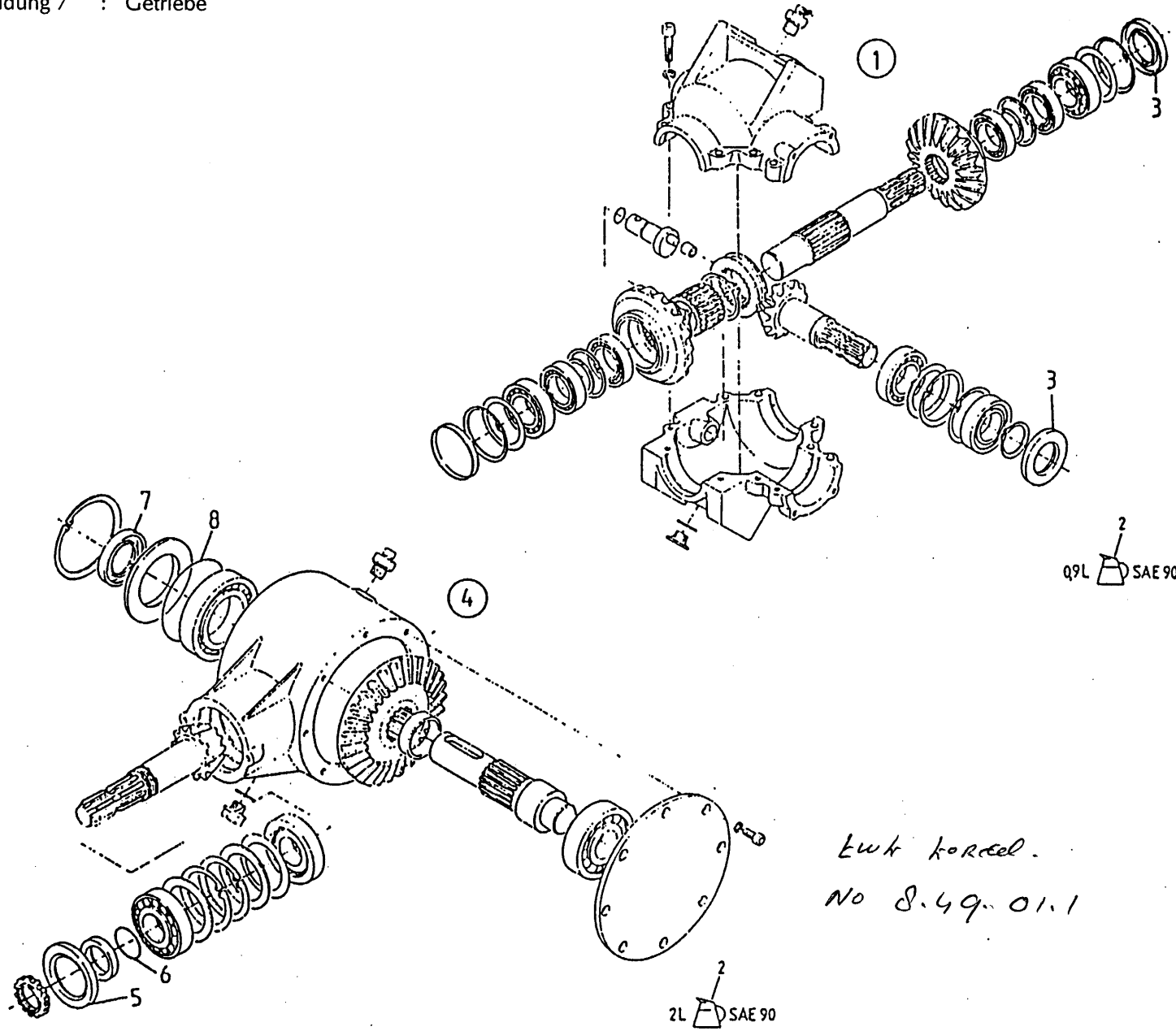

*Lucht korrel.
No 8.49.01.1*

bestelnummer
ordernummer
Num. à commander
Bestellnummer

1	90226	1	
2	90307	0,9L	
3	70109	2	40 x 80 x 10
4	90227	1	
2	90307	2L	
5	70108	1	60 x 90 x 8
6	78011	1	40 x 3
7	70107	1	45 x 80 x 10
8	78102	1	115 x 2,5

92105/1

Afbeelding 8 : Telescoop
 abbildung 8 : Teleskoparm

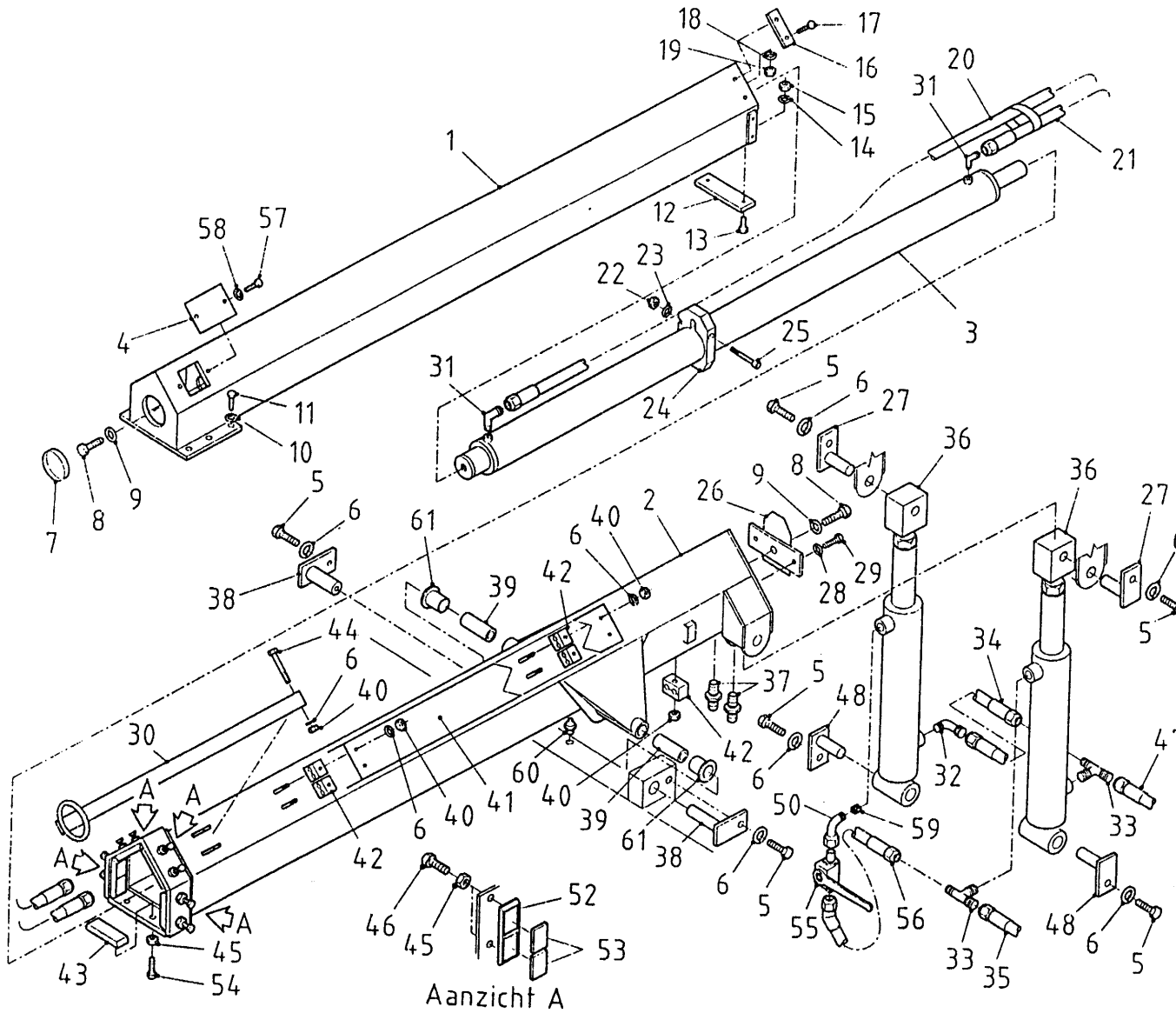

bestelnummer
 ordernummer
 num.à commander
 Bestellnummer

1	11211	1	
2	11210	1	
3	51005	1	
4	22907	1	
5	81021	6	M 10 x 20
6	85010	7	M 10
7	60202	1	
8	81860	2	M 18 x 60
9	85018	2	M 18
10	85020	6	M20
11	84435	6	M 20 x 45
12	60203	1	
13	84102	2	M 10 x 30
14	85110	2	M 10
15	86210	2	M 10
16	22904	4	
17	84123	8	M 6 x 20
18	85106	8	M 6
19	86206	8	M 6
20	W50784	1	½" 2250 RR
21	W50783	1	½" 700 RR
22	86210	1	M 10
23	85110	1	M 10
24	60205	1	
25	84434	1	M 10 x 100
26	11214	1	
27	11223	2	
28	85116	2	M 16
29	81641	2	M 16 x 40
30	11213	1	
31	X50101	2	
32	X50103	1	
33	X50356	2	
34	W50792	1	⅜" 300 45°Z 45°Z
35	W50790	1	⅜" 4500 RHZ
36A	51007	2	Serie 01
36B	51033	2	Serie 02
36C	51067	2	l→ 03

92105/1

Afbeelding 8 : Telescoop
 abbildung 8 : Teleskoparm

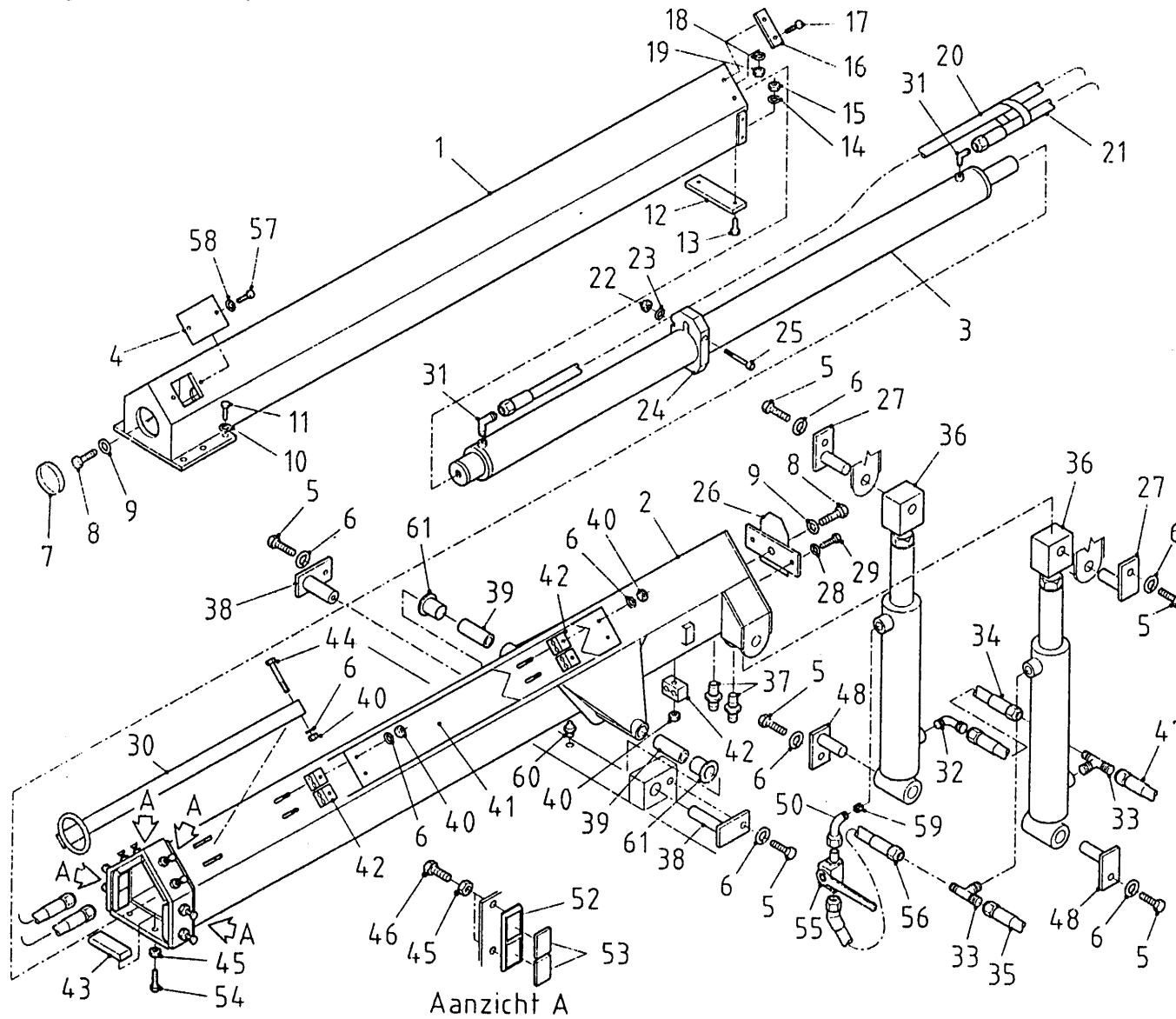

bestelnummer
 ordernummer
 num.à commander
 Bestellnummer

37	X50500	2	
38A	11226	2	→ 03
38B	11748	1	↳ 04
39	51760	2	
40	86208	5	M 8
41	40299	1	
42	90159	5	
43A	60204	1	→ 01
43B	60221	1	↳ 02
44	80880	1	M 8 x 80
45	86116	10	M 16
46	81661	8	M 16 x 60
47	W50808	1	3/8" 5200 RHZ
48	11224	2	
50A	X50146	1	→ 02
50B	X50103	1	↳ 03
52	21888	4	
53	60145	8	
54	81671	2	M 16 X 70
55	51023	1	
56	W50810	1	3/8" 400 RZ 45° Z
57	80816	2	M 8 x 16
58	85008	2	M 8
59	53187	1	0,8 mm
60	89503	1	M6
61	51854	2	↳ 04

92105/1

Afbeelding 9 : Snijstelsel

Abbildung 9 : Schneidvorrichtung

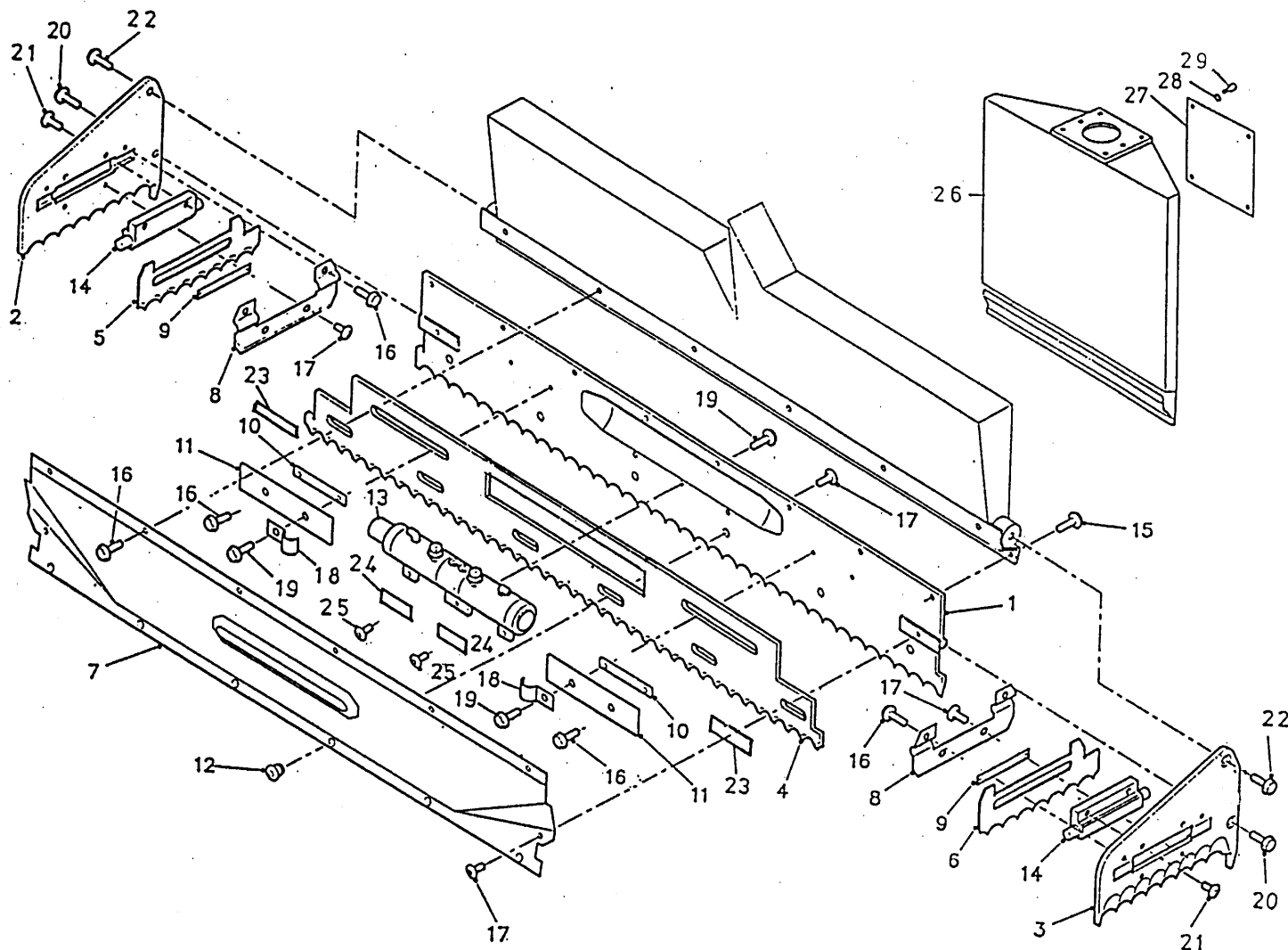

bestelnummer
ordernummer
num.à commander
Bestellnummer

1	11508	1	
2A	11659	1	Rechts serie 04
2B	11708	1	Rechts l→ 05
3A	11658	1	Links serie 04
3B	11707	1	Links l→ 05
4	25655	1	
5	25653	1	Rechts
6	25652	1	Links
7	11596	1	
8	23853	2	
9A	23854	2	BR=20 →l 06
9B	25657	2	BR=15 l→07
10	23854	4	
11	23848	2	
12	31327	8	
13	51119	1	18 mm 1 ring
14	51115	2	
15	83923	8	M12 x 20
16	83916	14	M10 x 16
17	83926	14	M10 x 19
18	24153	2	
19	83920	5	M10 x 20
20	83937	2	M12 x 30
21	83921	4	M10 x 25
22	83931	2	M16 x 30
23	24043	2	
24	25048	2	
25	81016	2	M10 x 16
26	11633	1	
27	24016	1	
28	85008	12	M8
29	84704	12	M18 x 16

92105/1

Afbeelding 10 : Slangenloop snijbord

Abbildung 10 : Schläuche Schneidschild

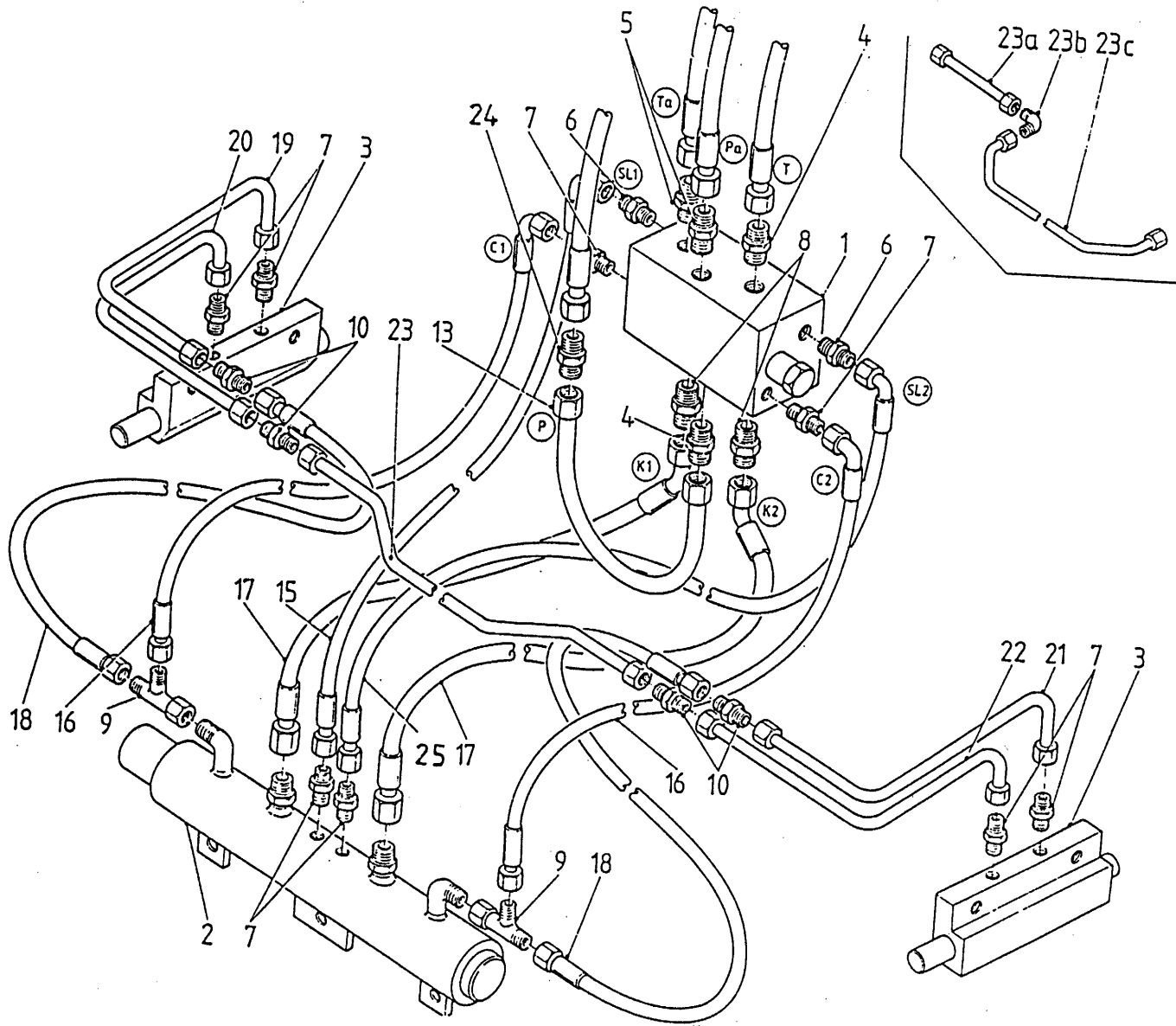

bestelnummer		ordernummer	
num.à commander		Bestellnummer	
1	53198	1	
2	51119	1	18 mm 1 ring
3	51115	2	
5	X50113	2	
6	X50114	2	
7	X50104	8	
8	X50102	4	
9	X50300	2	
10	X50135	4	
11	W50746	1	½" 850 R 45°
14	W50910	2	¾" 850 RR
15	W50971	1	¼" 400 H 20°
16	W50895	2	¼" 300 RH
17	W50970	2	¼" 300 RH
18	W50896	2	¼" 460 RR
19	50876	1	
20	50875	1	
21	50878	1	
22	50877	1	
23	50890	1	
25	X50143	1	
26	W50827	1	½" 1200 RR
27	X50500	2	
28	X50502	2	
29	85219	2	
30	85008	2	M8
31	80816	2	M8 x 16
32	85230	2	
33	22907	1	
34	W50808	1	¾" 5200 RHZ
35	W50790	1	¾" 4500 RHZ
36	W50789	2	½" 5150 RR ¼"
37	W50972	1	¼" 400 H 20°

92105/1

Afbeelding 11 : Stuurblok inwendig
 Abbildung 11 : Steuerblok Innenseite

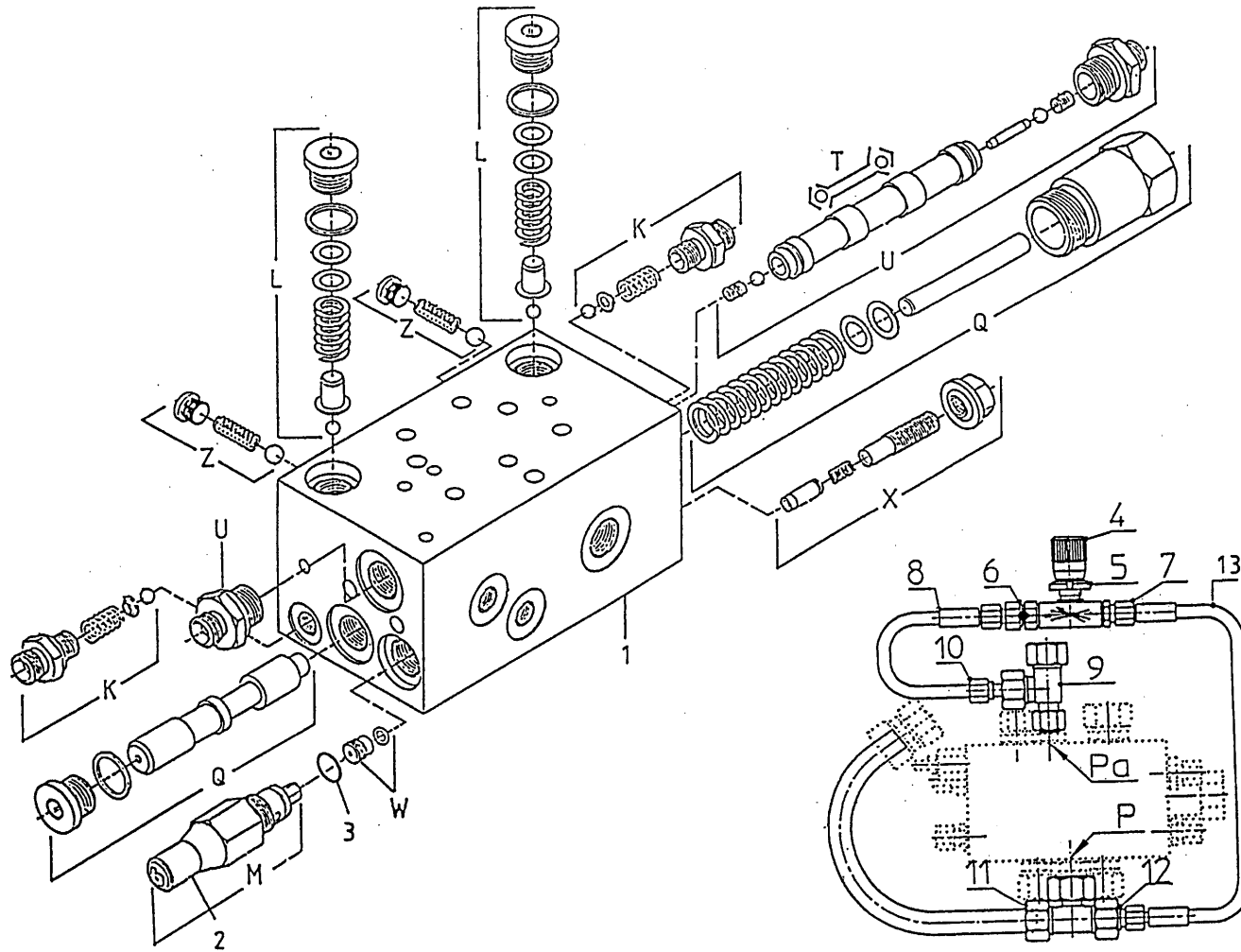

bestelnummer		ordernummer	
Num. à commander		Bestellnummer	
1	53198	1	
2	60260	1	
3	78053	1	12 x 1,5
4	53200	1	
5	86128	1	M20 x 1
6	53005	1	
7	X50201	1	
8	W50896	2	¼" 460 RR
9	X50309	1	
10	X50157	1	
11	X50312	1	
12	X50304	1	
13	W50719	1	¼" 900 RH
K	05049	2	10 bar
L	05264	2	200 bar
M	05265	1	
U	53150	1	
W	53256	1	
X	53257	7	

92105/1

Afbeelding 12 : Achter- en zijmescilinder
 Abbildung 12 : Heck- und Seitenzylinder

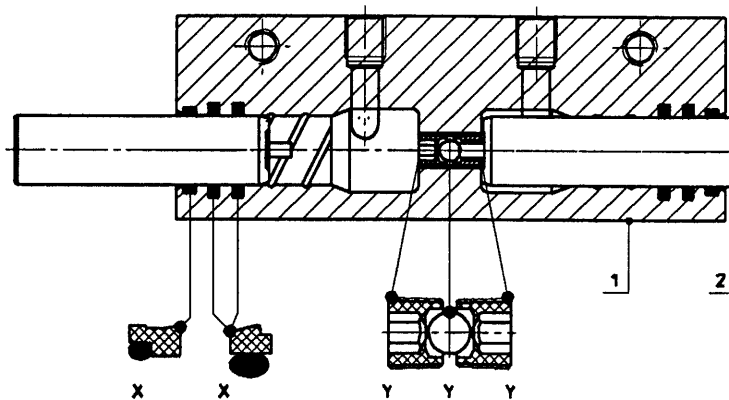
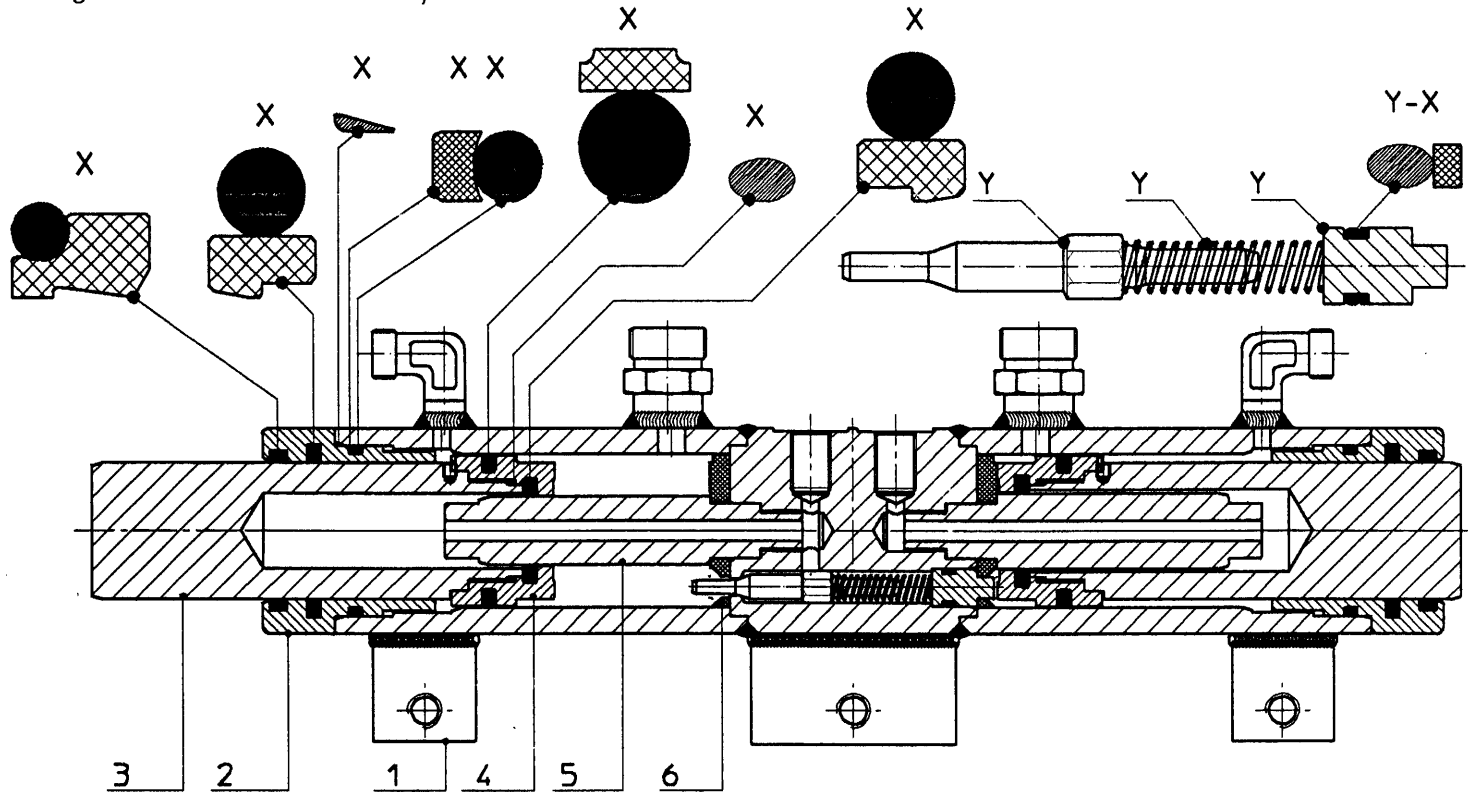

bestelnummer
 ordernummer
 Num. à commander
 Bestellnummer

51119

1	12106	1	
2	31421	2	
3	31455	2	1 ring
4	31453	2	
5	31454	2	18 mm
6	31428	2	
X	05306	1	
Y	05297	1	

51115

1	31772	1	
2	31436	2	
X	05294	1	
Y	05298	1	

92105/1

Afbeelding 13 : Mechanische afstandsbediening

Abbildung 13 : Mechanische Fernbedienung

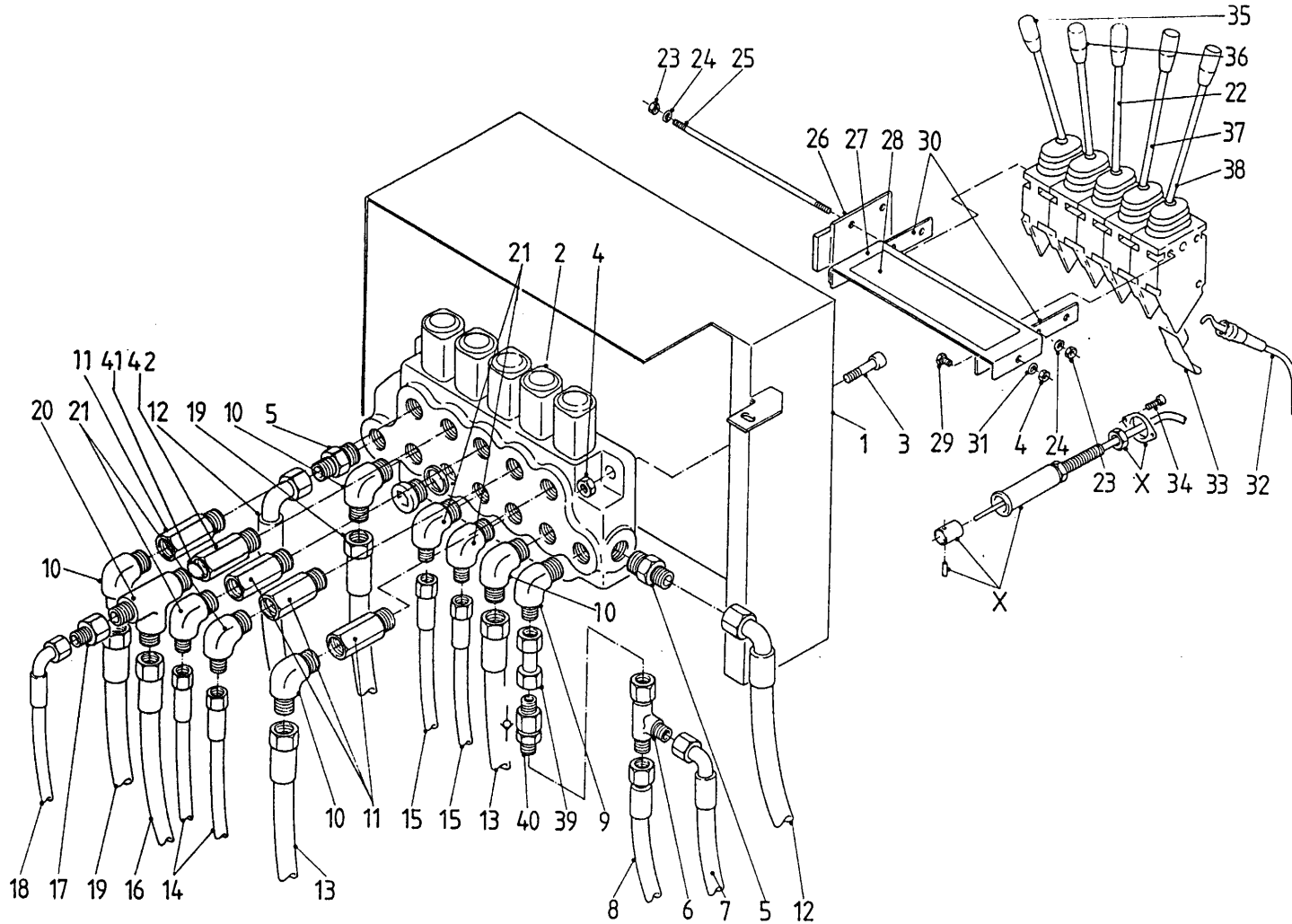

bestelnummer		ordernummer	
num.à commander		Bestellnummer	
1	22056	1	
2	53137	1	
3	84419	3	M 8 x 45
4	86208	5	M 8
5	X50102	2	
6	50309	1	
7	W50785	1	3/8" 4500 RH
8	W50796	1	3/8" 5050 RR
9	50103	1	
10	X50101	4	
11	50133	4	
12	W50768	2	1/2" 3000 RH
13	W50793	2	1/2" 2100 RR
14	W50719	2	1/4" 900 RH
15	W50807	2	1/4" 1050 RH
16	W50794	1	3/8" 1000 RZ 45° Z
17	X50168	1	
18	W50787	1	1/4" 600 RZ HZ
19	W50789	2	1/2" 5150 RR
20	X50302	1	
21	X50118	4	
22	53099	1	
23	86206	6	M 6
24	85106	6	M 6
25	84159	3	M 6 x 240
26	11139	1	
27	22245	1	
28	91112	1	
29	80816	2	M 8 x 16
30	22244	2	
31	85108	2	M 8
32	79060	5	L = 3000
33	60210	5	
34	84426	10	M 6 x 16
35	53128	1	30° R
36	53127	1	15° R
37	53129	1	15° L
38	53130	1	30° L
39	50777	1	
40	53170	1	
41	53173	1	2 mm
42	31377	1	
X	05207	5	

92105/1

Afbeelding 14 : Elektrische bediening

Abbildung 14 : Elektrische Bedienung

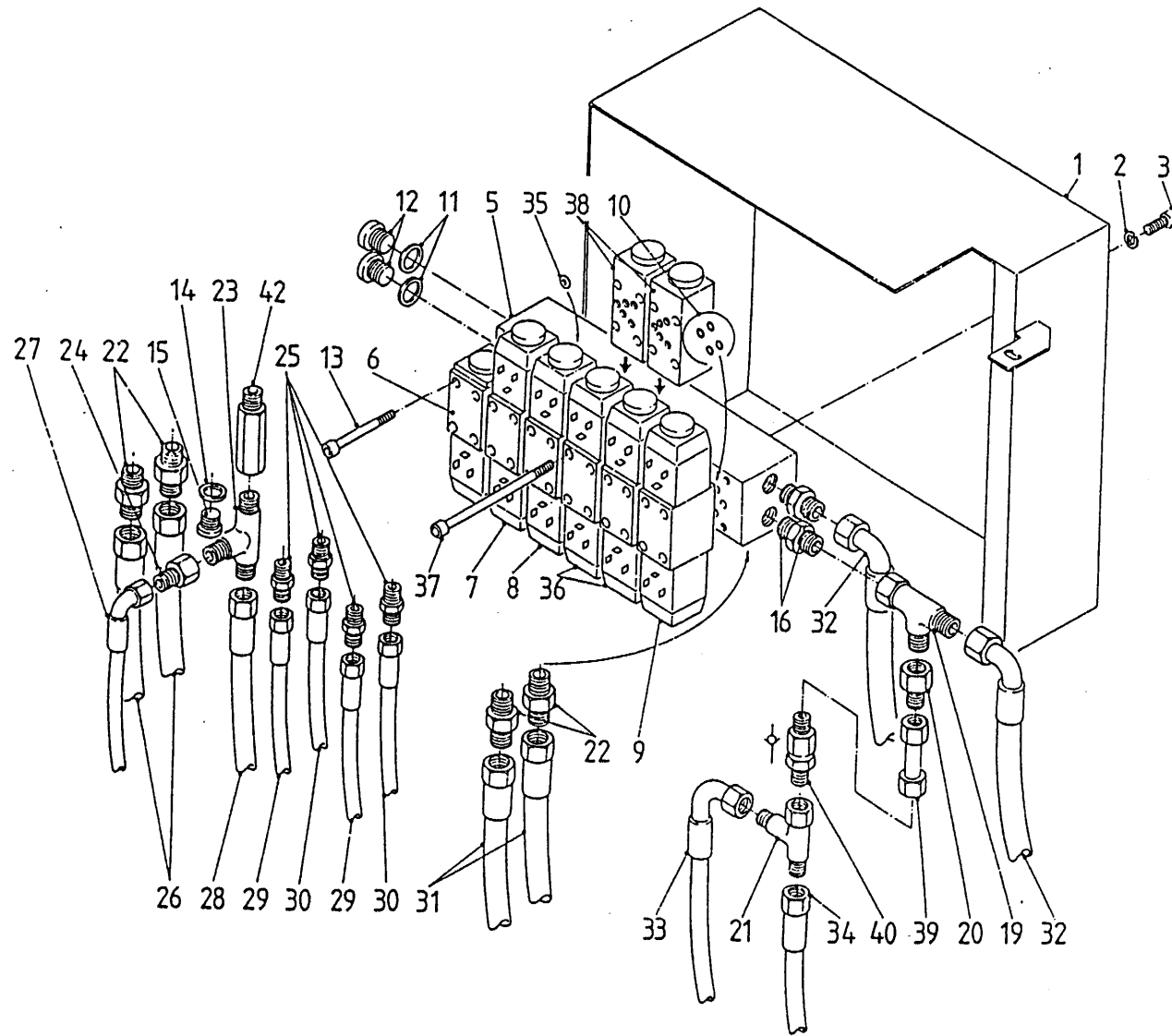

bestelnummer
 ordernummer
 num.à commander
 Bestellnummer

1	22056	1	
2	85008	4	M 8
3	84420	4	M 8 x 16
5	53067	1	
6	53080	1	
7	53105	1	
8	53079	3	
9	53104	1	
10	78057	24	
11	85225	2	
12	53316	2	
13	84433	24	M 5 x 30
14	85215	1	
15	53319	1	
16	X50142	2	
19	X50303	1	
20	50154	1	
22	X50102	4	
23	X50302	1	
24	X50168	1	
25	X50114	4	
26	W50789	2	½" 5150 RR
27	W50787	1	¼" 600 RZ HZ
28	W50794	1	⅜" 1000 RZ 45° Z
29	W50719	2	¼" 900 RH
30	W50807	2	¼" 1050 RR
31	W50793	2	½" 2100 RR
32	W50768	2	½" 3000 RH
33	W50785	1	⅜" 4500 RH
34	W50796	1	⅜" 5050 RR
35	31214	1	φ 2,6 mm
36	53135	2	
37	84438	8	M5 x 70
38	53149	2	
39	50777	1	
40	X53170	1	
41	X50359	1	
42	31377	1	
43	53173	1	φ 2 mm

92105/1

Afbeelding 15 : Bedieningskast en aansluitschema

Abbildung 15 : Bedienungspult und Schaltplan

bestelnummer
ordernummer
num.à commander
Bestellnummer

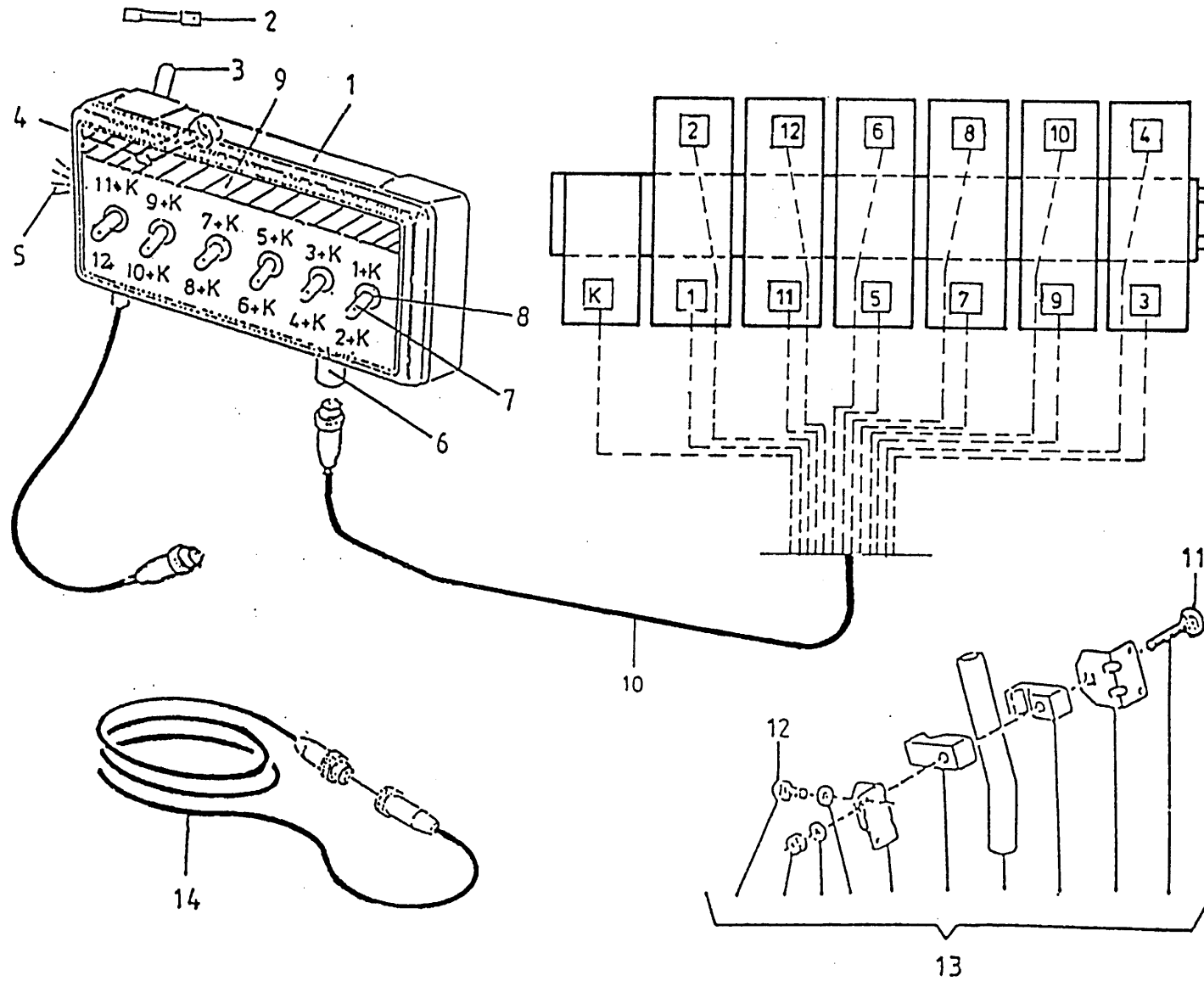

1	98073	1
2	98053	1
3	98054	1
4	98052	1
5	98051	1
6	98058	1
7	98056	5
8	98055	5
9	91015	1
10	98069	1
11	83150	1
12	84305	1
13	05154	1
14	98065	1

92105/1

Afbeelding 16 : Schakelcilinder en zijklepcilinder

Abbildung 16 : Schaltzylinder und Seitenklappezylinder

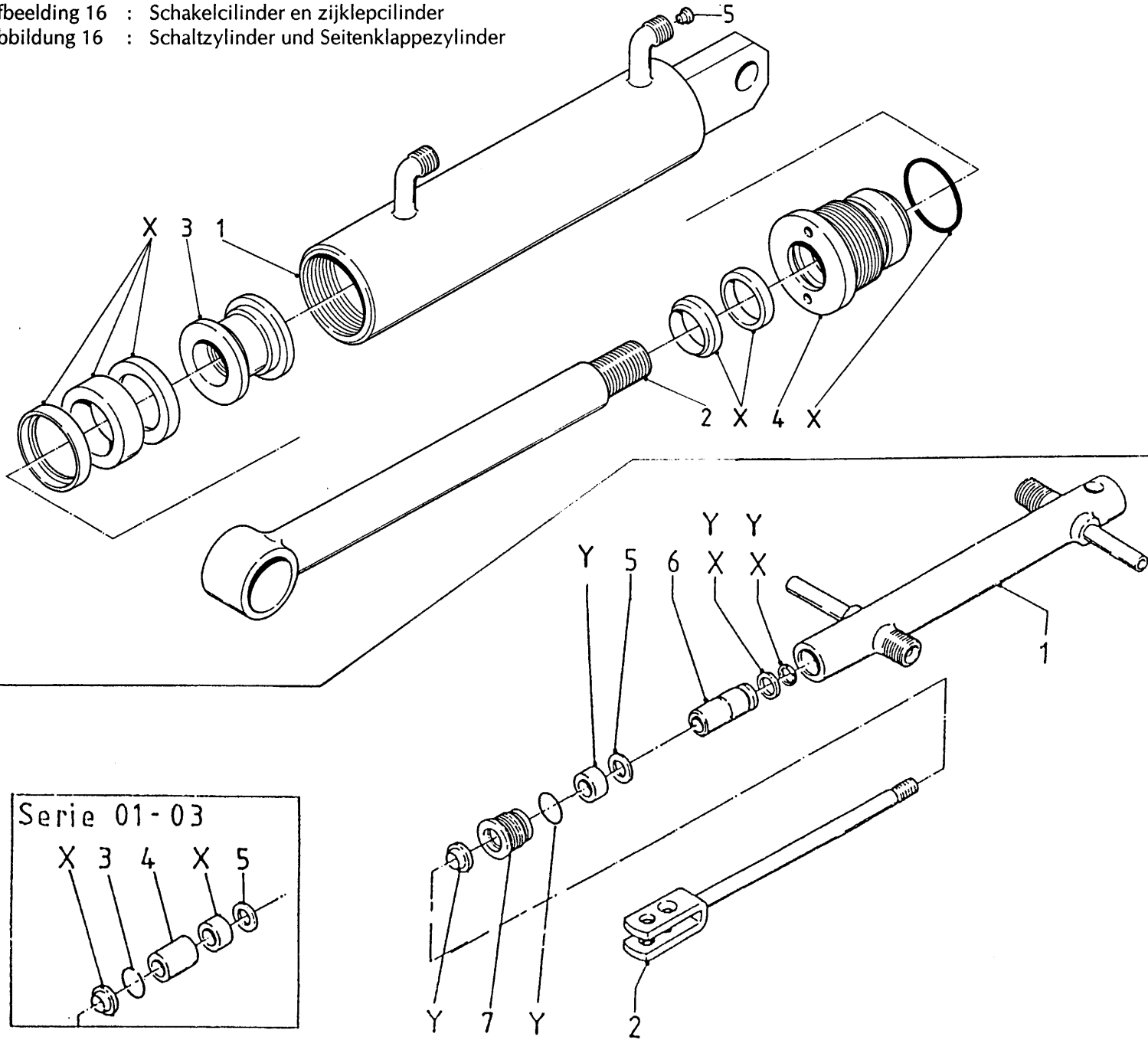

bestelnummer
 ordernummer
 num.à commander
 Bestellnummer

50100

1	10969	1	
2	11132	1	
3	30860	1	
4	30859	1	
5	30726	1	
X	05206	1	

51012 / 51024 / 51055 / 51075 / 51098

1A	11410	1	Serie 01 75 mm
1B	11245	1	Serie 02 75 mm
1C	11546	1	Serie 03 85 mm
1D	11716	1	Serie 04 85 mm
1E	11879	1	↳ 05
2A	11246	1	Serie 01 + 02
2B	11545	1	↳ 03
3	85803	1	↳ 03
4	31099	1	↳ 03
5	31100	1	
6	31101	1	
7	31523	1	↳ 04
X	05218	1	
Y	05319	1	

92105/1

Afbeelding 17 : Cilinders teleskoop
 Abbildung 17 : Zylinder Teleskop

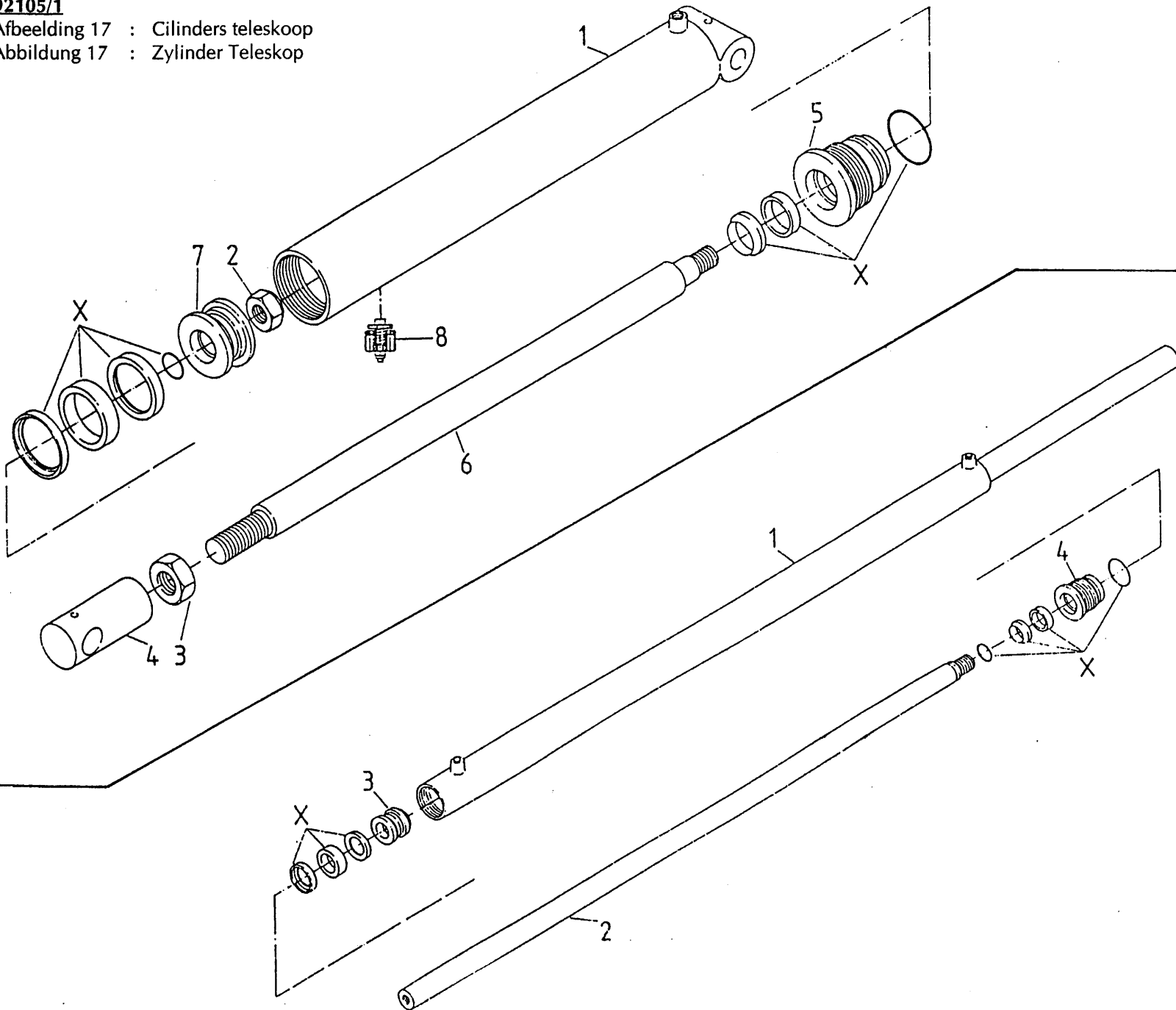

bestelnummer	51033/51067
ordernummer	
num.à commander	
Bestelnummer	

51033/51067			
1A	11218	1	→ 02
1B	11464	1	→ 03
2	86227	1	
3	86920	1	
4	31001	1	
5	31085	1	
6	31086	1	
7	30911	1	
8	53187	1	0,8 mm
X	05209	1	

51005

1	11216	1	
2	31076	1	
3	31077	1	
4	31078	1	
X	05210	1	

92105/1

Afbeelding 18 : Dissel en wielarmcilinder

Abbildung 18 : Deichsel- und Radarmzylinder

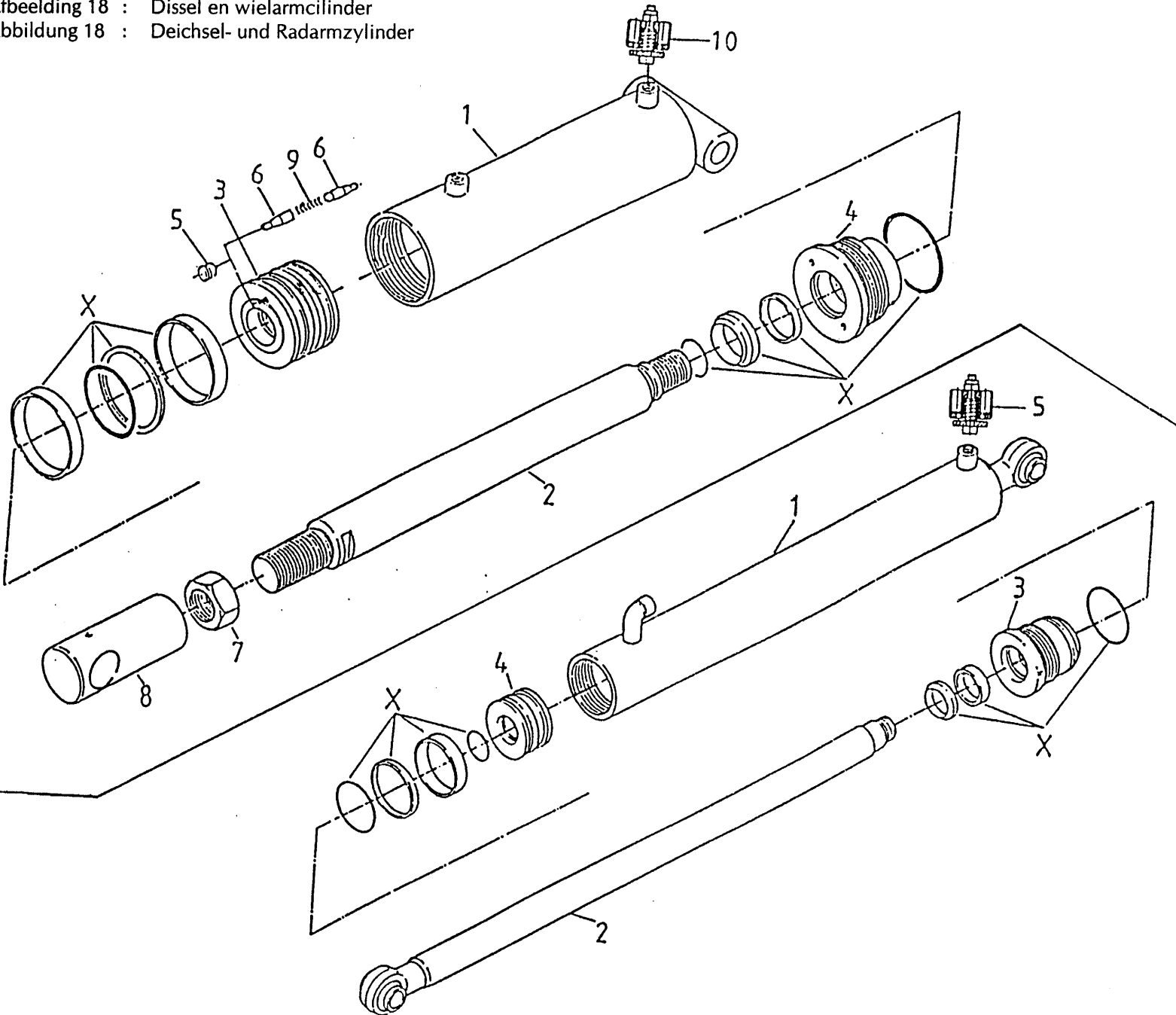

bestelnummer
ordernummer
num.à commander
Bestellnummer

51006

1	11217	1	
2	31094	1	
3	31082	1	
4	31083	1	
5	30870	1	
6	31277	1	
7	86920	1	
8	31001	1	
9	65062	1	
10	53172	1	1,0 mm
X	05212	1	

51002/51066

1A	11171	1	serie 01 + 02
1B	11625	1	serie 03
2	11172	1	
3	30520	1	
4	31043	1	
5	53183	1	0,65 mm
X	05211	1	

92105/1

Afbeelding 19 : Aftakassen

Abbildung 19 : Gelenkwellen

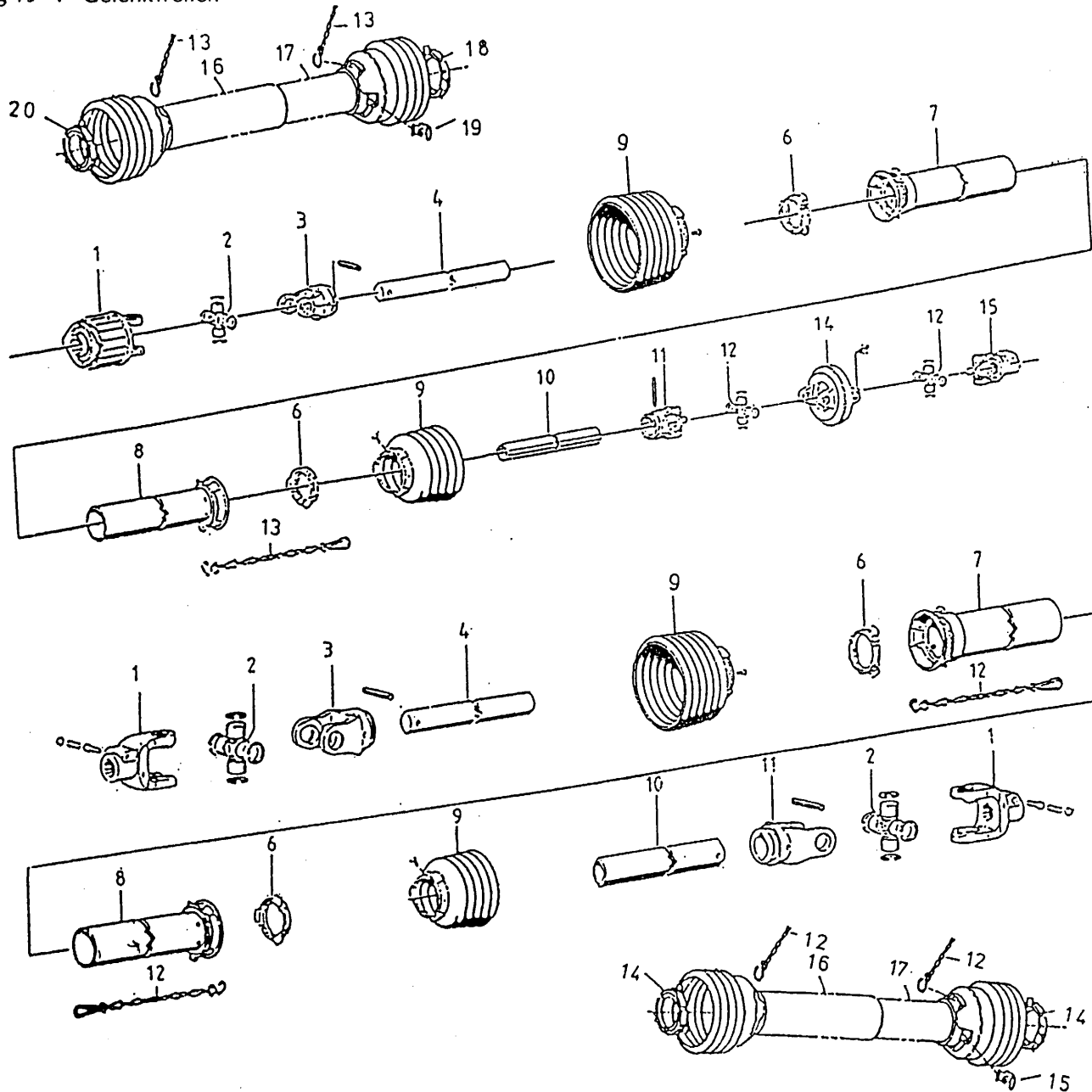

bestelnummer
 ordernummer
 num.à commander
 Bestellnummer

90232

1	90237	1	
2	90249	1	
3	90238	1	
4	90239	1	
6	90241	2	→ 02
7	90242	1	→ 02
8	90243	1	→ 02
9	90245	2	→ 02
10	90246	1	
11	90251	2	
12	90252	2	
13	90266	2	
14	90254	1	
15	90272	1	
16	90355	1	→ 03
17	90351	1	→ 03
18	90357	1	→ 03
19	90349	2	→ 03
20	90361	1	→ 03

90233

1	90255	2	
2	90256	2	
3	90257	1	
4	90258	1	→ 02
6	90260	2	→ 02
7	90261	1	→ 02
8	90262	1	→ 02
9	90263	2	
10	90264	1	
11	90265	1	
12	90266	2	→ 03
14	90358	2	→ 03
15	90349	2	→ 03
16	90359	1	→ 03
17	90360	1	

92105/1

Afbeelding 20 : Electronisch weegsysteem

Abbildung 20 : Electronische Waage

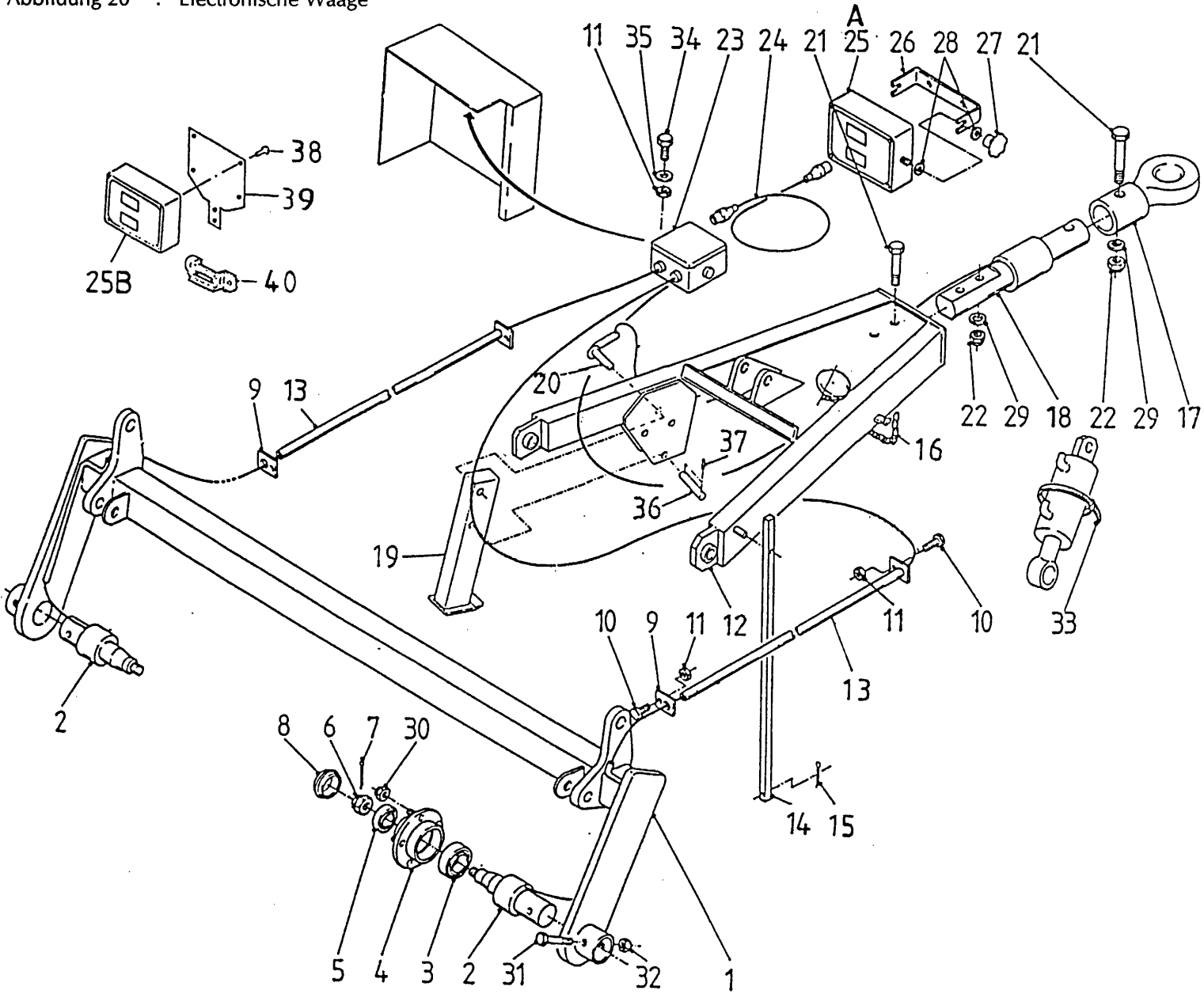

bestelnummer
ordernummer
Num. à commander
Bestellnummer

1A	11547	1	22,5 mm → I 05
1B	11811	1	0 mm I → 06
2A	90299	1	Links
2B	90353	1	Rechts
3	70057	2	
4	90308	2	
5	70056	2	
6	90223	2	
7	90224	2	
8	90225	2	
9	23623	2	
10	80825	4	M8 x 25
11	86208	5	M8
12	11272	1	
13	11436	2	
14	22953	1	
15	88242	1	∅ 3,5 x 30
16	39136	1	
17	11355	1	
18	90276	1	
19	11735	1	
20	11736	1	
21	82010	3	M20 x 100
22	86220	3	M20
23	98075	1	
24	98076	1	
25A	90300	1	→ I 06
25B	90539	1	I → 07
26	23633	1	
27	60024	2	
28	60022	4	
29	85120	3	M20
30	86922	12	M18
31	81610	2	M16 x 100
32	86216	2	M16
33	90109	24	
34	80820	2	M8 x 20
35	85108	2	M8
36	31548	1	
37	88030	1	∅ 6 x 30
38	81016	4	M10 x 16
39	40475	1	
40	20199	1	

92105/1

Afbeelding 21 : Hydraulisch schema mechanische bediening

Abbildung 21 : Hydraulischer Schaltplan mechanische Fernbediening

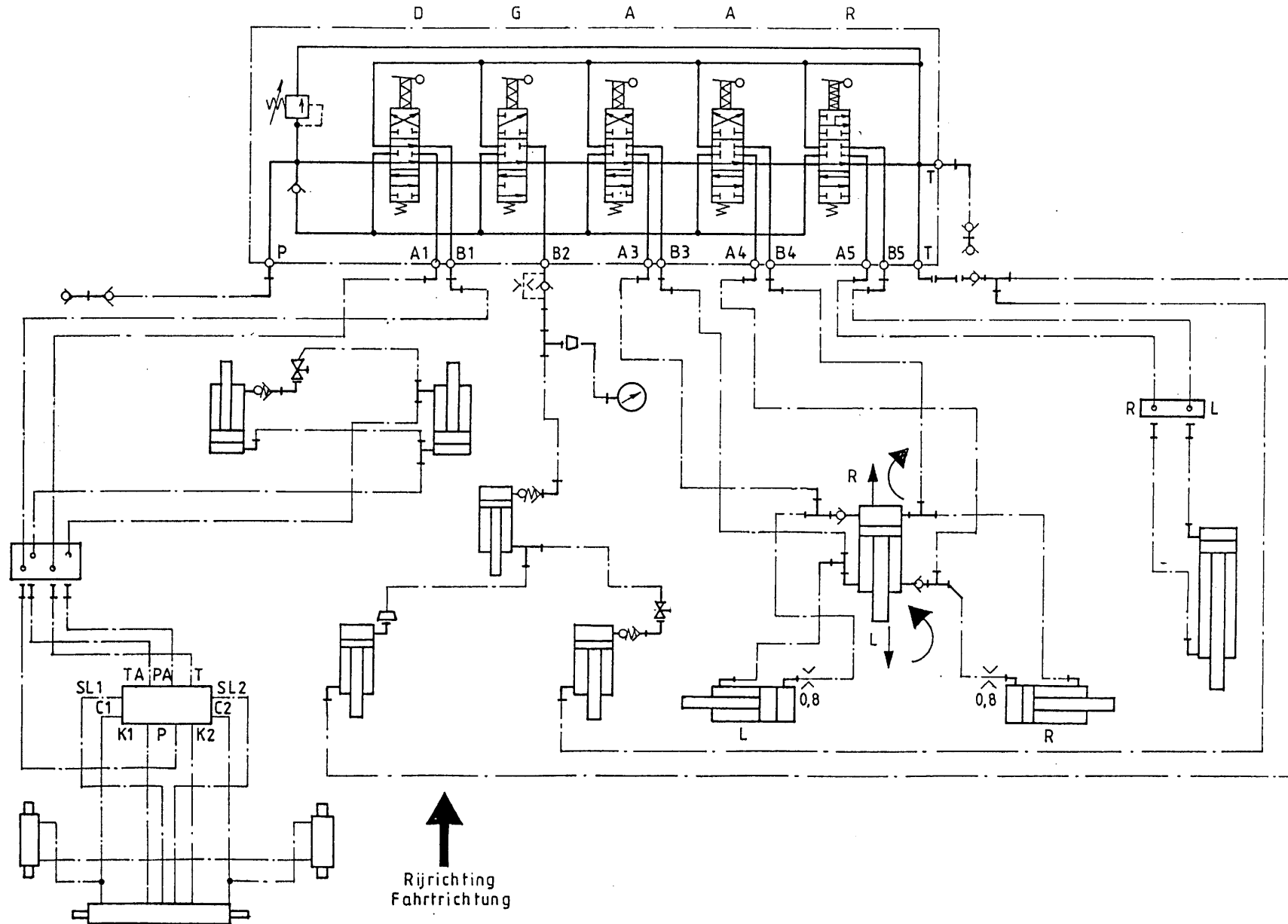

92105/1

Afbeelding 22 : Hydraulisch schema elektrische bediening

Abbildung 22 : Hydraulischer Schaltplan elektrische Fernbedienung

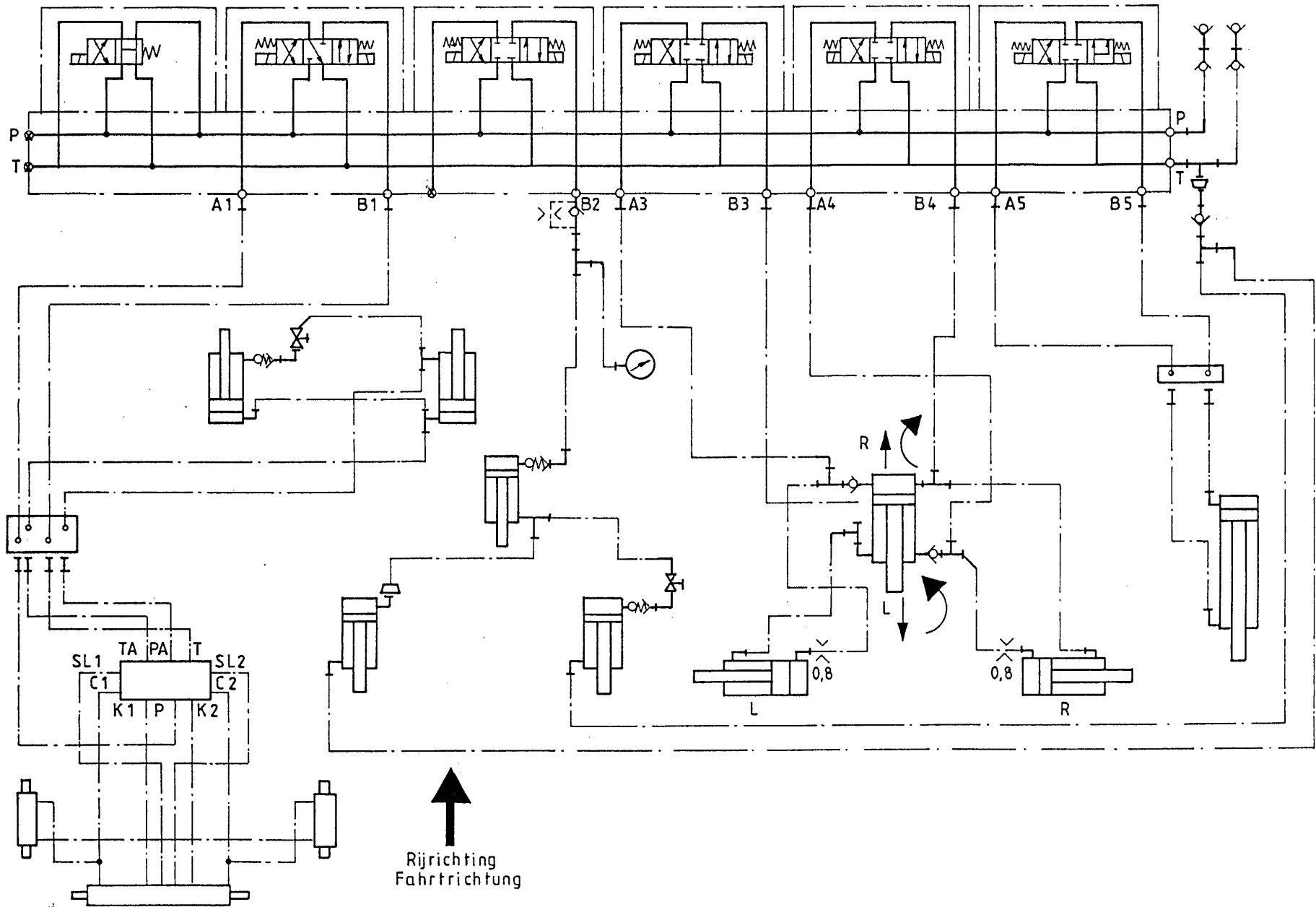

92015/1

Afbeelding 23 : Elektrisch schema

Abbildung 23 : Elektrischer Schaltplan

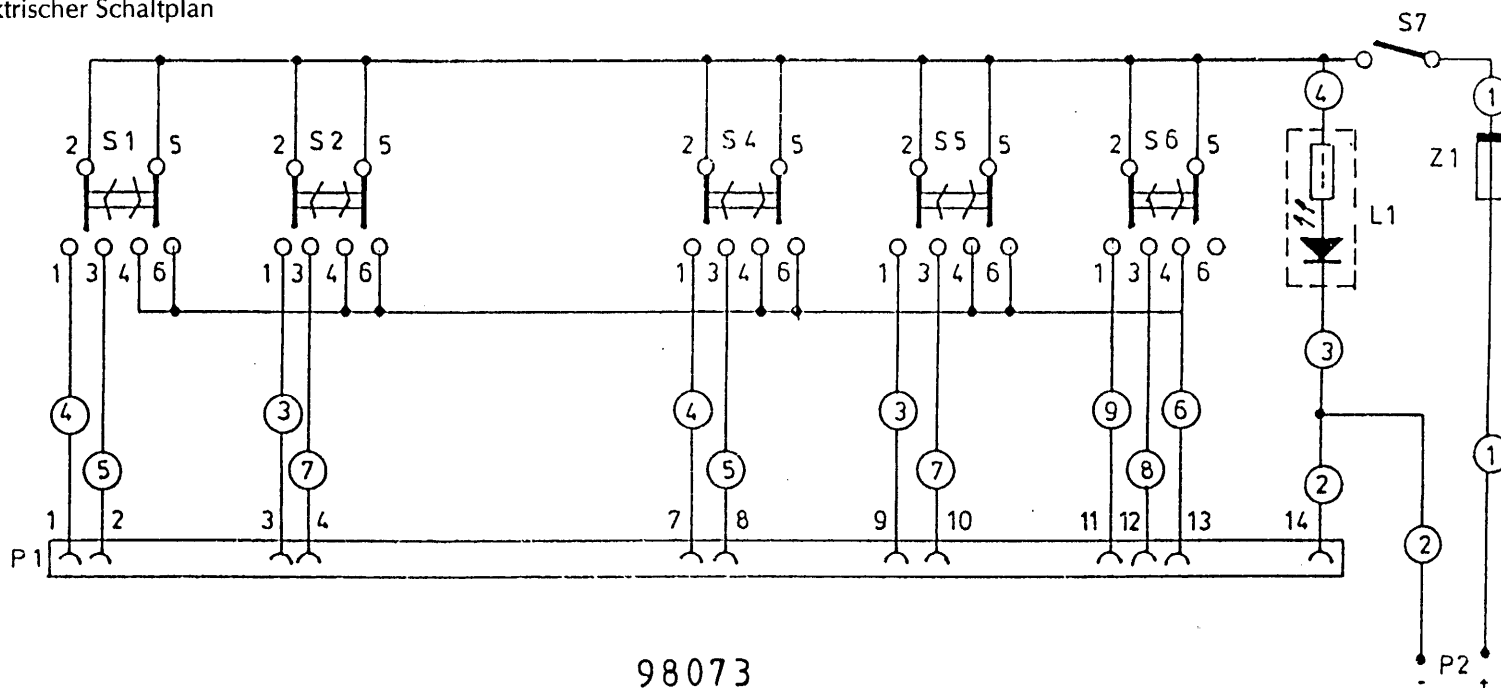

98073

	Kleurcodering	Farbenschlüssel	Colour code	Codes des couleurs
1	Bruin	Braun	Brown	Brun
2	Blauw	Blau	Blue	Bleu
3	Geel	Gelb	Yellow	Jaune
4	Rood	Rot	Red	Rouge
5	Oranje	Orange	Orange	Orange
6	Paars	Violet	Purple	Violet
7	Groen	Grün	Green	Vert
8	Wit	Weiß	White	Blanc
9	Grijs	Grau	Grey	Gris

TRIOLIET

Trioliet Mullos BV
Himmanweg 19
7575 BE Oldenzaal - Holland

Postbus 134
7570 AC Oldenzaal - Holland

Tel.: 0541 - 57 21 21 / (+) 31 - 541 - 57 21 21
Fax: 0541 - 57 21 25 / (+) 31 - 541 - 57 21 25

Voor onderdelen / Für Ersatzteile:
Tel.: 0541 - 57 21 36 / (+) 31 - 541 - 57 21 36
Fax: 0541 - 57 21 40 / (+) 31 - 541 - 57 21 40