

TRIO LIET

Trioliet

*Uitkuildoseermengwagen
Siloentnahmemischwagen*

Triomix

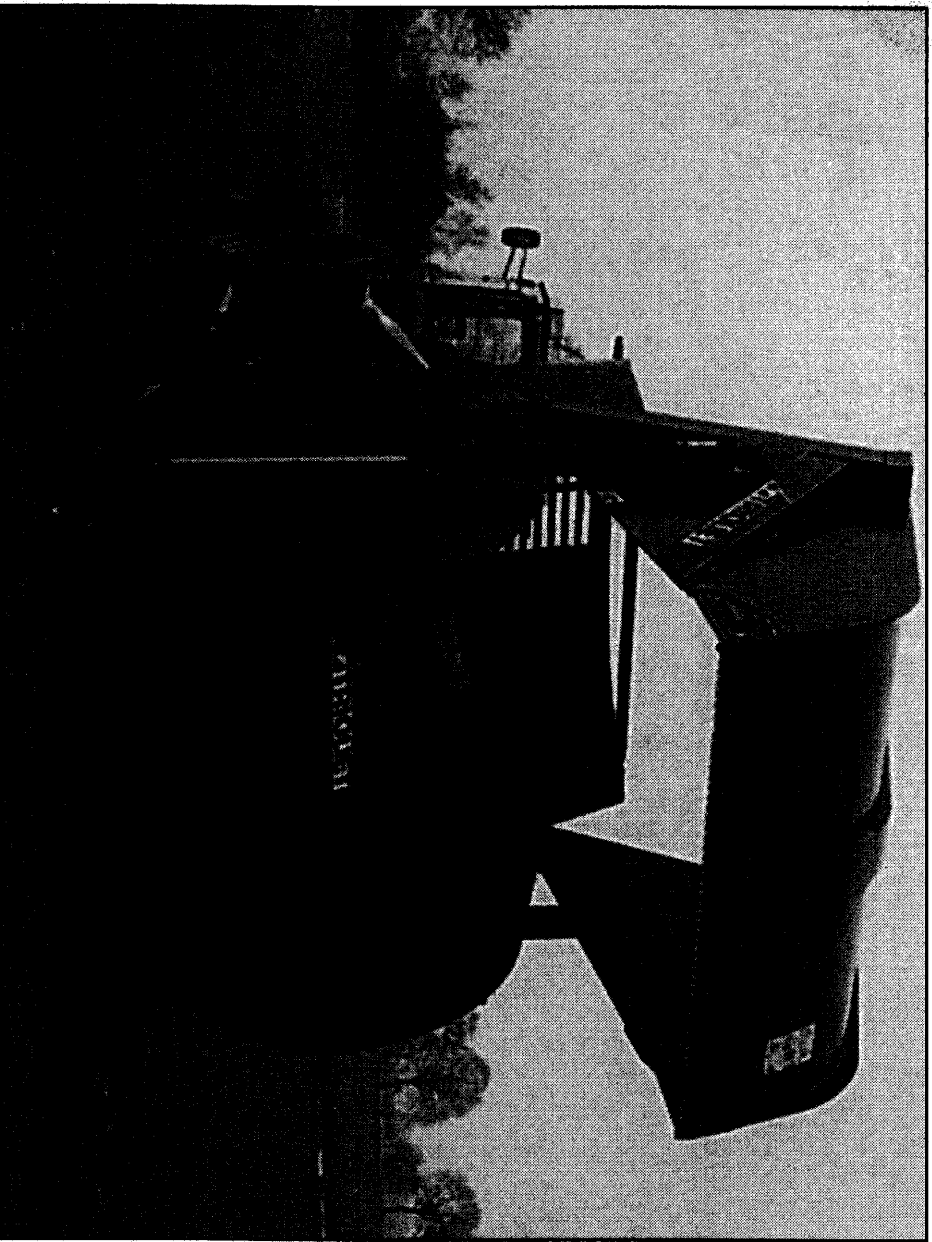

*Onderdelen- en Werkplaatshandboek
Ersatzteilliste und Werkstatthandbuch*

Bestelnummer / Bestellnummer 92126/1

Geldig vanaf productieserie nr. / Gültig ab Prod. Serie No.: 01

92126/1

Afbeelding 1 : Stickers
 Abbildung 1 : Aufkleber

bestelnummer
 ordernummer
 Num. à commander
 Bestellnummer

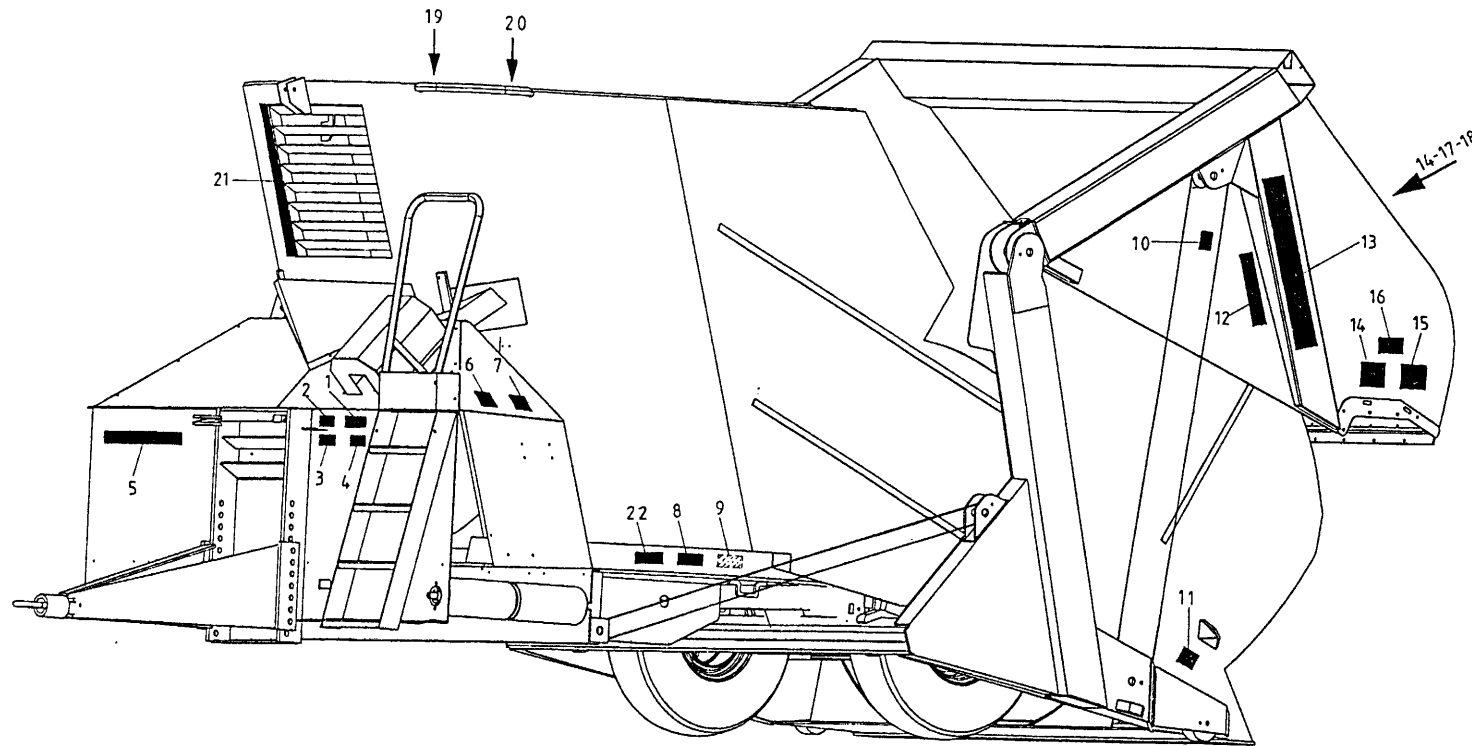

1	91159	1	
2	91160	1	
3	91243	1	
4	91185	1	
5	91247	1	
6	91162	2	
7	91211	2	
8	91183	2	
9	91118	1	
10	91182	1	
11	91197	2	
12	91251	2	
13	91249	2	
14	91189	3	
15	91198	2	
17	91153	1	
18	91241	1	
19	91240	1	
20	91242	1	
21	91143	1	
22	91228	2	

92126/1

Afbeelding 2 : Dissel

Abbildung 2 : Deichsel

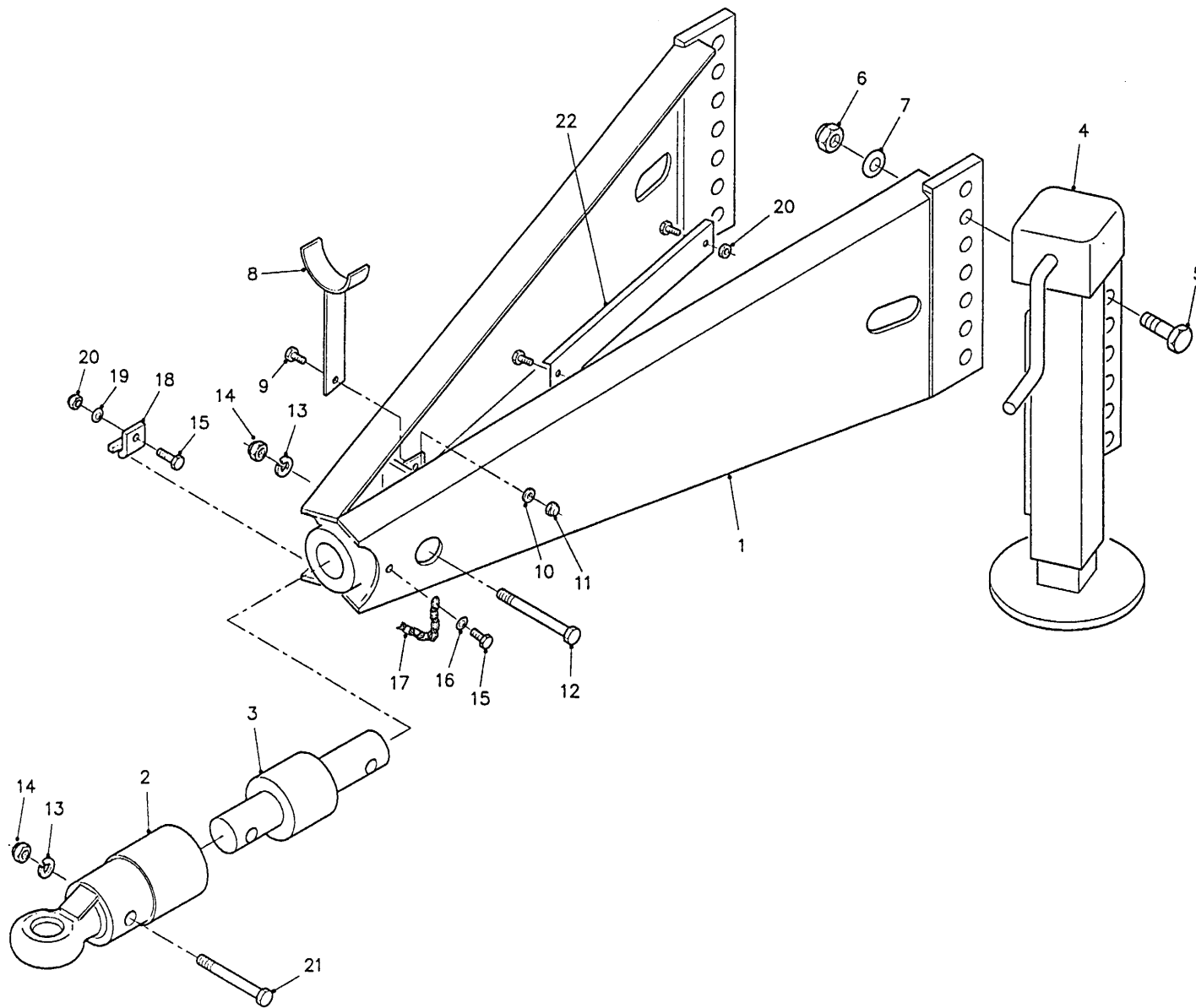

bestelnummer
ordernummer
Num. à commander
Bestelnummer

1	11942	1	
2	12229	1	
3	31746	1	
4	11946	1	
5A	82409	3	M24 x 90
5B	82470	2	M24x70
6	86224	5	M24
7	85124	5	M24
8	11709	1	
9	81026	1	M10 x 25
10	85110	1	M10
11	86210	1	M10
12	82014	2	M20 x 140
13	85020	3	M20
14	86220	3	M20
15	80831	2	M8 x 30
16	85109	1	M8
17	39136	1	
18	24528	1	
19	85108	1	M8
20	86208	3	M8
21	82013	1	M20 x 130
22	40431	1	

92126/1

Afbeelding 3 : Wielas met hydraulisch remsysteem

Abbildung 3 : Radachse mit hydraulischer Bremse

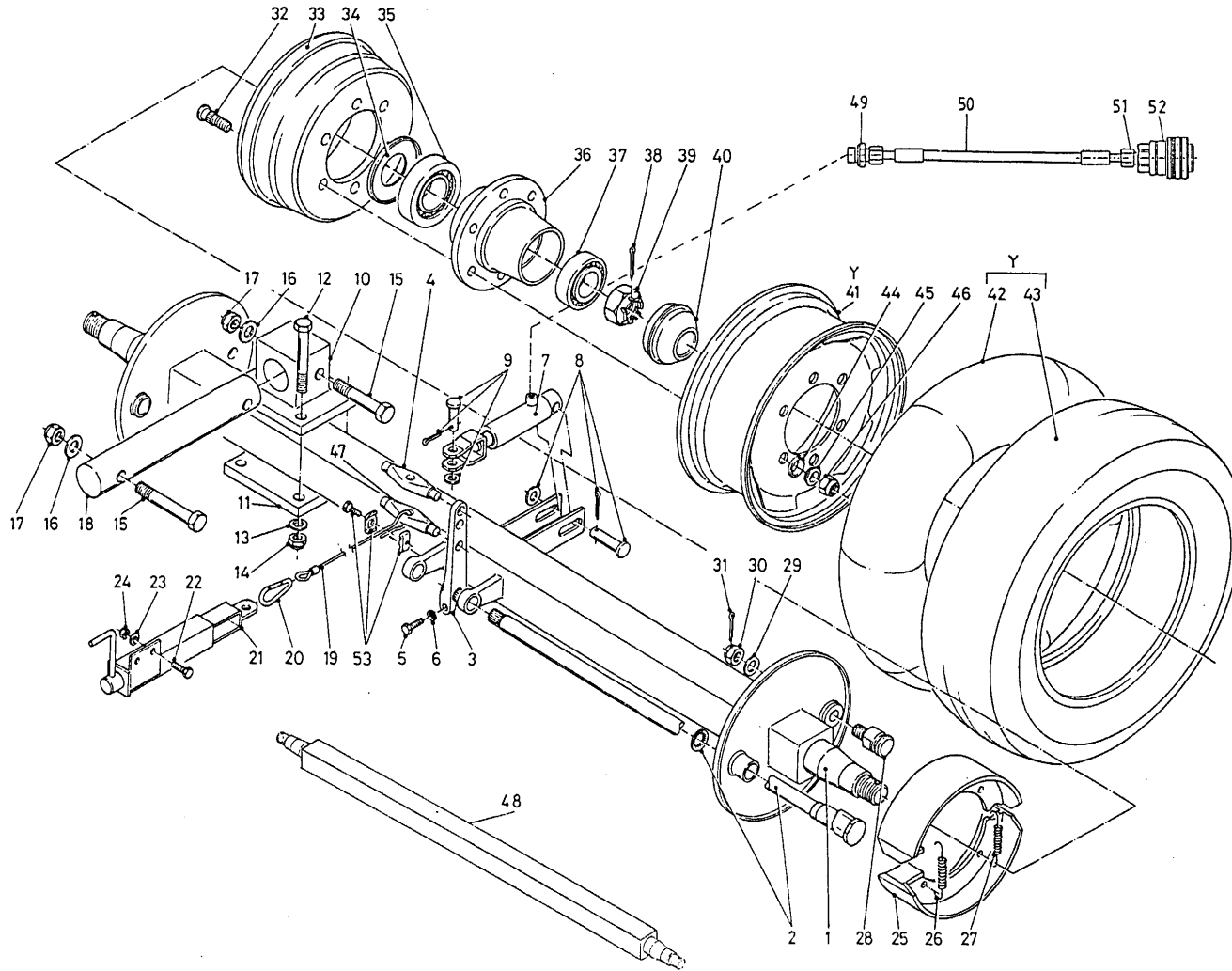

bestelnummer		ordernummer	
Num. à commander		Bestellnummer	
1	90487	1	
2	90508	2	
3	90507	2	
4	90506	1	
5	81060	2	M10 x 60
6	86110	2	M10
7	51110	1	
8	90514	1	
9	90515	1	
10	11945	2	
11	25221	2	
12	81615	8	M16 x 140
13	85016	8	M16
14	86516	8	M16
15	82013	4	M20 x 130
16	85020	4	M20
17	86220	4	M20
18	31746	2	
19	79082	1	L=3170
20	39139	1	
21	11997	1	
22	81031	2	M10 x 30
23	85110	2	M10
24	86210	2	M10
25	90509	4	
26	90512	2	
27	90513	2	
28	90510	2	
29	90523	2	
30	90511	2	
31	90524	2	
32A	84939	12	M18 x 1,5 L=60
32B	84938	12	M18x1.5L=74
33	90502	2	
34	90503	2	
35	70132	2	
36	90501	2	
37	70131	2	
38	90522	2	

92126/1

Afbeelding 3 : Wielas met hydraulisch remsysteem

Abbildung 3 : Radachse mit hydraulischer Bremse

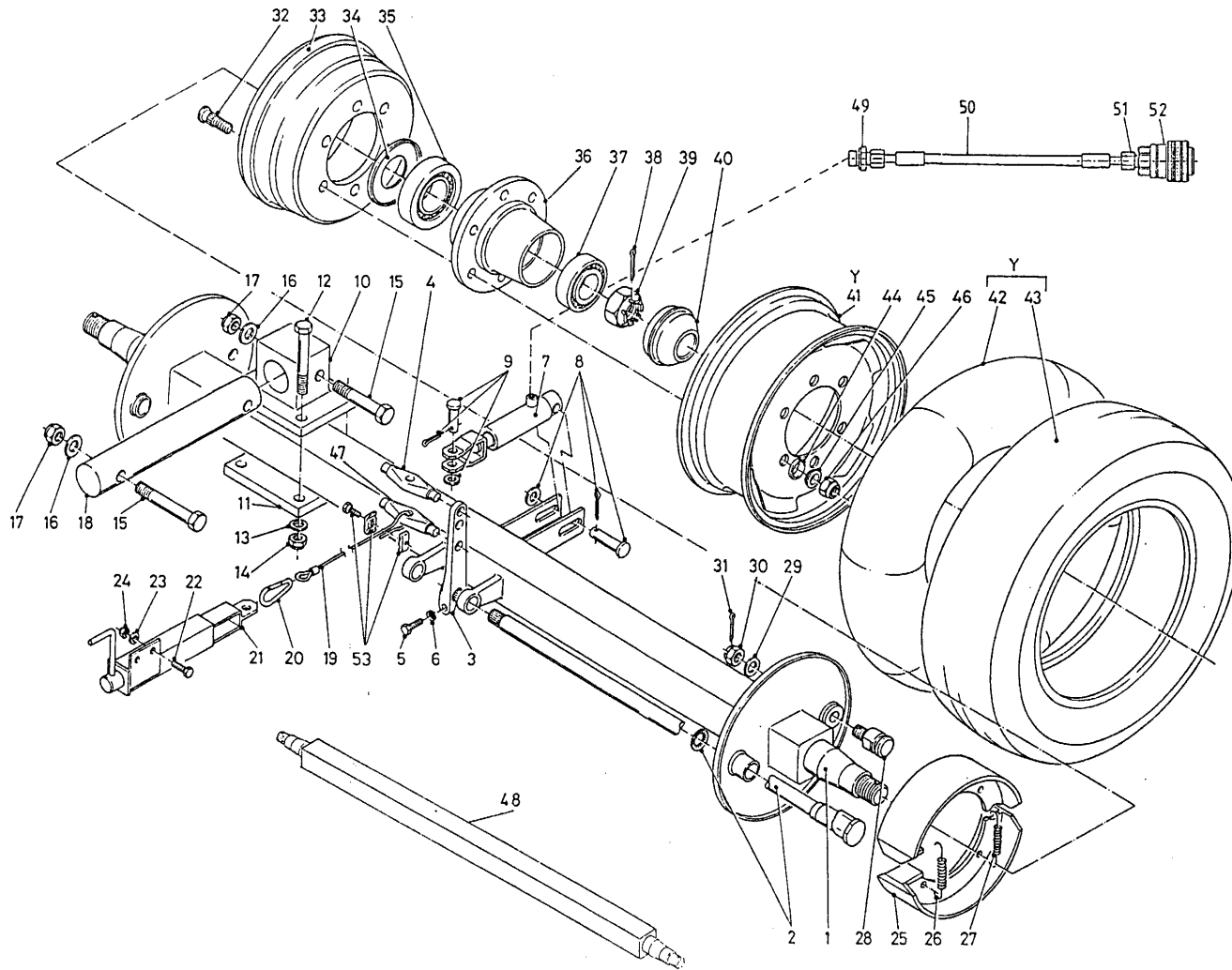

bestelnummer
 ordernummer
 Num. à commander
 Bestellnummer

39	90504	2	
40	90505	2	
41	90341	2	8J x 16
42	90343	2	8,25 x 16
43	90342	2	H34 x 10,- R16
44	90520	12	
45	90521	12	
46	90519	12	M18 x 1,5 H=18
47	31747	1	
48	90531	1	
49	X50124	1	
50	W50920	1	¼" 6500 RR
51	X50114	1	
52	53327	1	
53	90430	1	
Y	90339	1	

92126/1

Afbeelding 4 : Frame
 Abbildung 4 : Rahmen

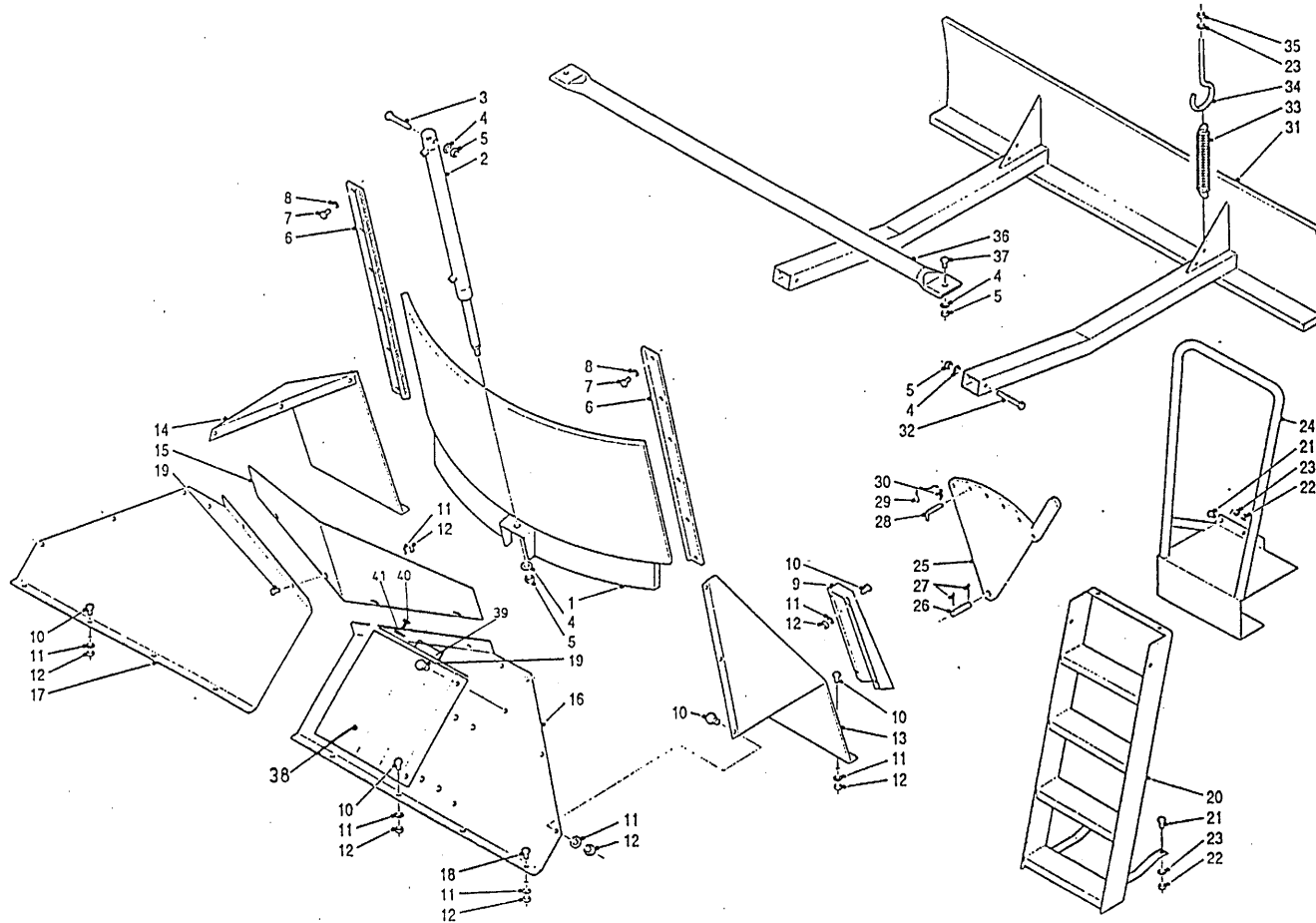

bestelnummer
 ordernummer
 Num. à commander
 Bestellnummer

1A	11916	1	8m ³
1B	11682	1	10m ³ /12m ³
1C	12012	1	14m ³
2	51062	1	
3	81690	1	M16 x 90
4	85116	5	M16
5	86216	5	M16
6	11690	2	
7	81031	14	M10 x 30
8	85010	14	M10
9	11983	1	
10	80821	34	M8 x 20
11	85108	40	M8
12	86208	36	M8
13A	25203	1	8m ³
13B	25506	1	10m ³ /12m ³
13C	26007	1	14m ³
14A	25204	1	8m ³
14B	25507	1	10m ³ /12m ³
14C	26008	1	14m ³
15	40434	1	
16A	25201	1	8m ³
16B	25504	1	10m ³ /12m ³
16C	26006	1	14m ³
17A	25202	1	8m ³
17B	25503	1	10m ³ /12m ³
17C	26005	1	14m ³
18	80831	2	M8 x 30
19	80810	4	M8 x 10
20	11906	1	
21	81021	4	M10 x 20
22	86210	4	M10
23	85110	6	M10
24	11981	1	
25	11958	1	
26	25332	1	
27	88239	2	Ø5 x 40

92126/1

Afbeelding 4 : Frame
 Abbildung 4 : Rahmen

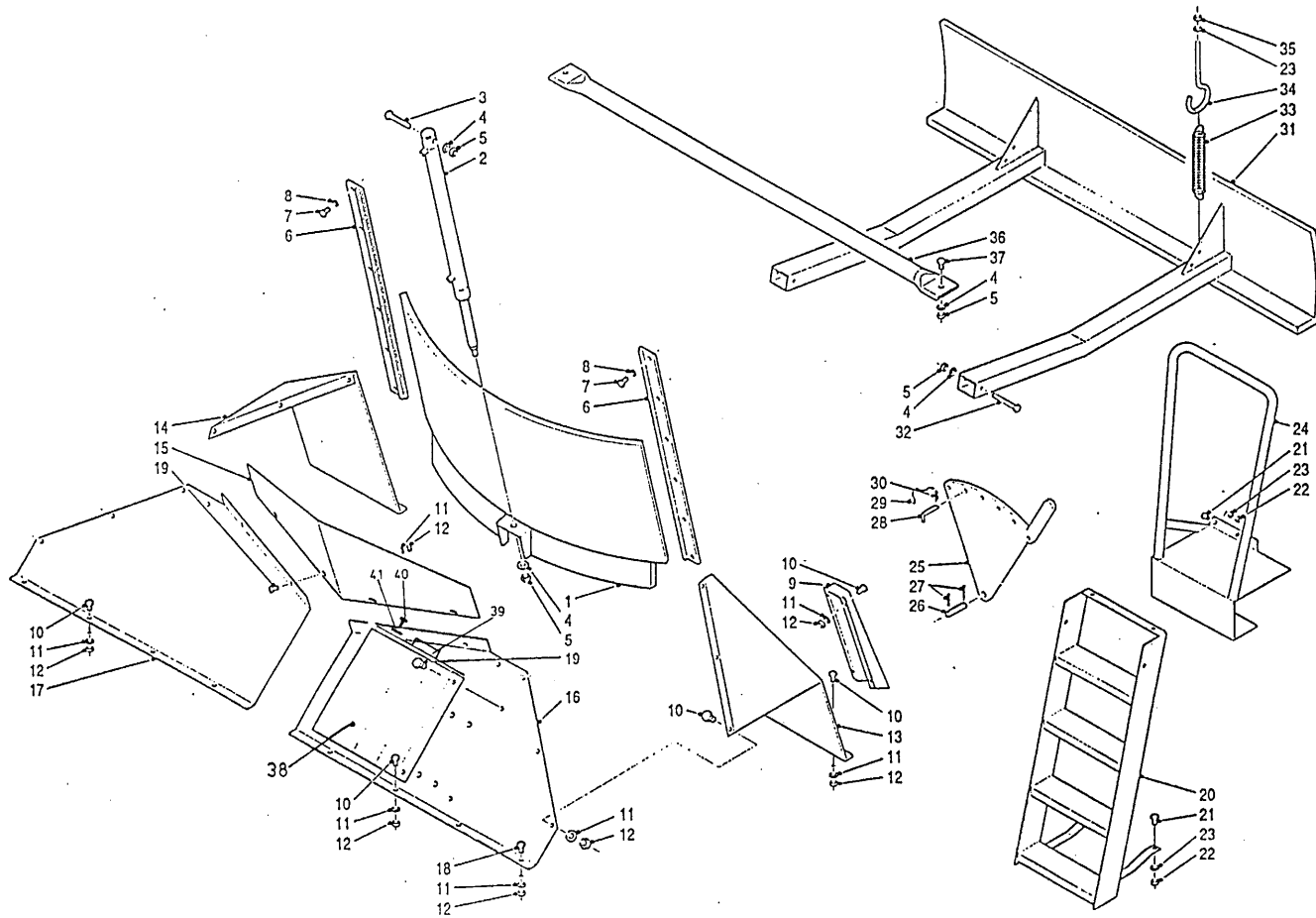

bestelnummer
 ordernummer
 Num. à commander
 Bestellnummer

28	90490	1	
29	90282	1	
30	65030	1	
31A	11938	1	8m ³
31B	12091	1	10m ³ /12m ³
31C	12132	1	14m ³
32	81615	2	M16 x 140
33	65059	2	
34	84174	2	
35	86110	2	M10
36A	25184	1	8m ³
36B	25682	1	10m ³ /12m ³
36C	26015	1	14m ³
37	81650	2	M16 x 50
38A	12024	1	→01
38B	12136	1	→02
39	26529	1	→02
40	80816	3	M8x16
41	85108	3	M8

92126/1

Afbeelding 5 : Dwarsband
 Abbildung 5 : Querförderband

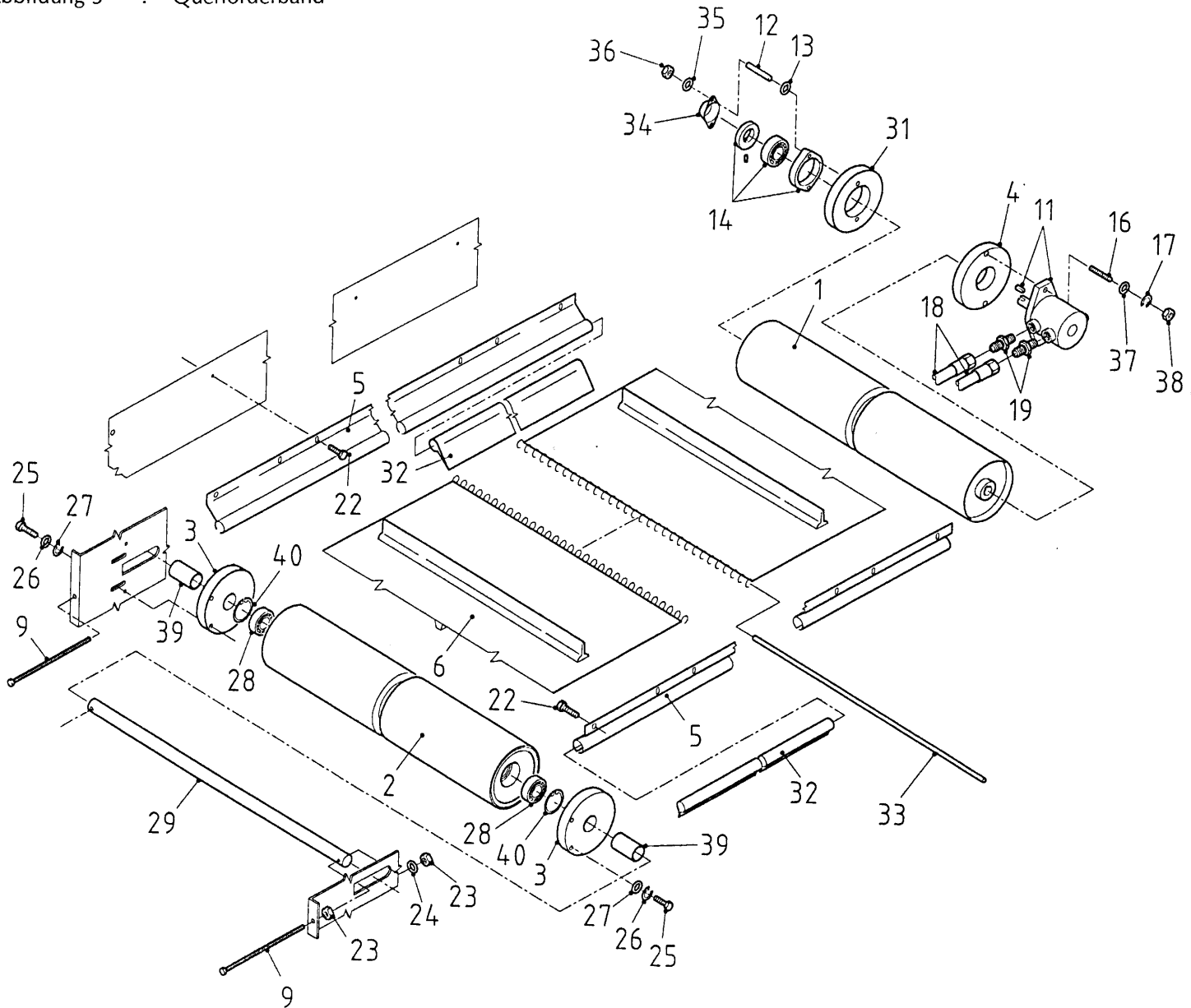

bestelnummer		ordernummer	Num. à commander	Bestellnummer
1	11940	1		
2	11979	1		
3	60290	2		
4	31709	1		
5A	90274	2	8m ³	
5B	90535	2	10m ³ /12m ³	
5C	90634	2	14m ³	
6A	60294	1	8m ³	
6B	60297	1	10m ³ /12m ³	
6C	60306	1	14m ³	
9	81223	2	M12 x 180	
11A	51109	1	White 160cc→I01	
11B	51080	1	Danfoss 160cc→I01	
11C	51083	1	White 127cc I→02	
11D	51129	1	Sam 127cc I→02	
12	84108	2	M8 x 60	
13	85112	2	M8	
14	70084	1		
16	84108	2	M12 x 60	
17	85112	2	M12	
18	W50602	2	½" 3500 RH	
19	X50117	2		
22	84715	22	M6 x 16	
23	86112	4	M12	
24	85012	2	M12	
25	81031	4	M10 x 30	
26	85010	4	M10	
27	85113	4	M10	
28	70010	2		
29	25200	1		
31	60289	1		
32A	60216	2	8m ³ L=2280	
32B	60296	2	10m ³ /12m ³ L=2460	
32C	60305	2	14m ³ L=2750	
33	25422	1		
34	23304	1		
35	85008	2	M8	
36	86208	2	M8	
37	85012	2	M12	
38	86212	2	M12	
39	25207	2	L=53	
40	87162	2		

92126/1

Afbeelding 6A : Aandrijving en mengvijzel 8 m³ / 10 m³ / 12 m³

Abbildung 6A : Schnecke und Antrieb 8 m³ / 10 m³ / 12 m³

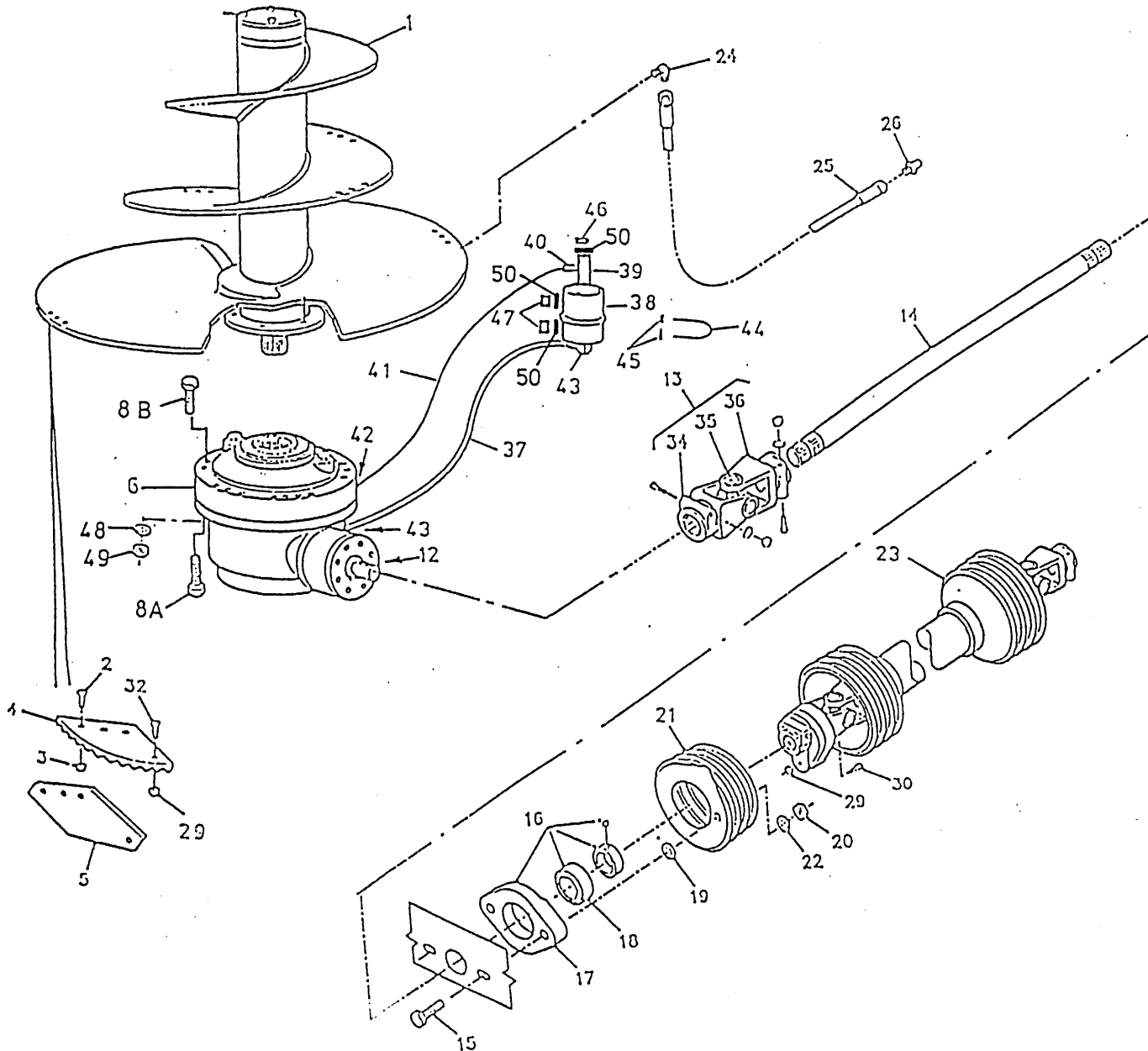

bestelnummer
 ordernummer
 Num. à commander
 Bestellnummer

1A	11965	1	8m ³
1B	12069	1	10m ³
1C	12099	1	12m ³
2	84120	15	M16 x 50
3	86216	15	M16
4A	31639	5	L = 550
4B	31853	5	L = 350
5	31640	5	
6A	90437	1	8m ³ → I01 Ø 48 RR
6B	90516	1	8m ³ → I01 1 3/8" 6 RR
6C	90546	1	1 3/4"-20 SOM
6D	90650	1	1 3/4"-20 BR
6E	90574	1	1 3/8"-6 BR
8A	84482	12	M14 x 100 8m ³
8B	81415	12	M14 x 160 10m ³ 12m ³
12	88371	1	14 x 9 x 70
13A	90609	1	8m ³ → I01 Ø 48 / 1 3/8"-6
13B	90497	1	1 3/8"-6 / 1 3/8"-6
13C	90545	1	1 3/4"-20 / 1 3/8"-6
14A	31720	1	8m ³ → I01 L = 1330
14B	31635	1	8m ³ → I02 L = 1270
14C	31760	1	10m ³ / 12m ³ L = 1370
15	81071	2	M10 x 70
16	70059	1	
17	70089	1	
18	70090	1	
19	85113	2	M10
20	86110	2	M10
21	90499	1	
22	85010	2	M10
23	90495	1	
24	50107	1	
25	50957	1	1/4" 1520 RR
26	89518	1	
29	86208	1	M8
30	80860	1	M8 x 60
32	84101	5	M8 x 20
34B	90563	1	1 3/8"-6

92126/1

Afbeelding 6A : Aandrijving en mengvijzel 8 m³ / 10 m³ / 12 m³

Abbildung 6A : Schnecke und Antrieb 8 m³ / 10 m³ / 12 m³

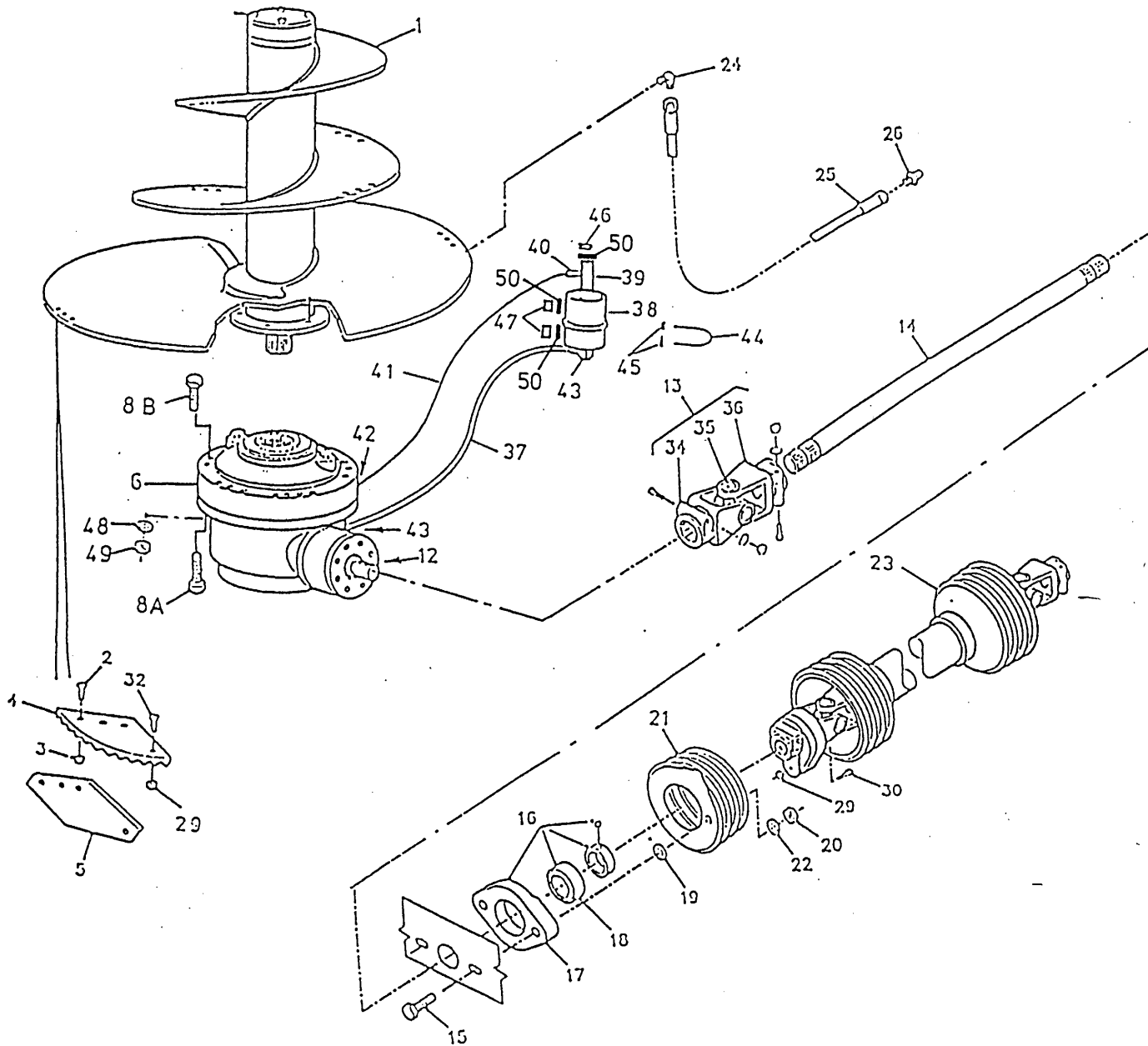

bestelnummer
 ordernummer
 Num. à commander
 Bestellnummer

34C	90562	1	1 3/4"-20
35	90561	1	
36	90563	1	
37	W50665	1	3/8" 1850 RH
38	90443	1	
39	50176	1	
40	50177	1	
41	50950	1	
42	50181	1	
43	X50112	2	
44	84191	1	
45	86206	2	M6
46	90567	1	
47	90566	2	
48	85114	12	M 14
49	86214	12	M 14
50	85215	3	

92126/1

Afbeelding 6B : Aandrijving en Mengvijzel 14m³

Abbildung 6B : Schnecke und Antrieb 14m³

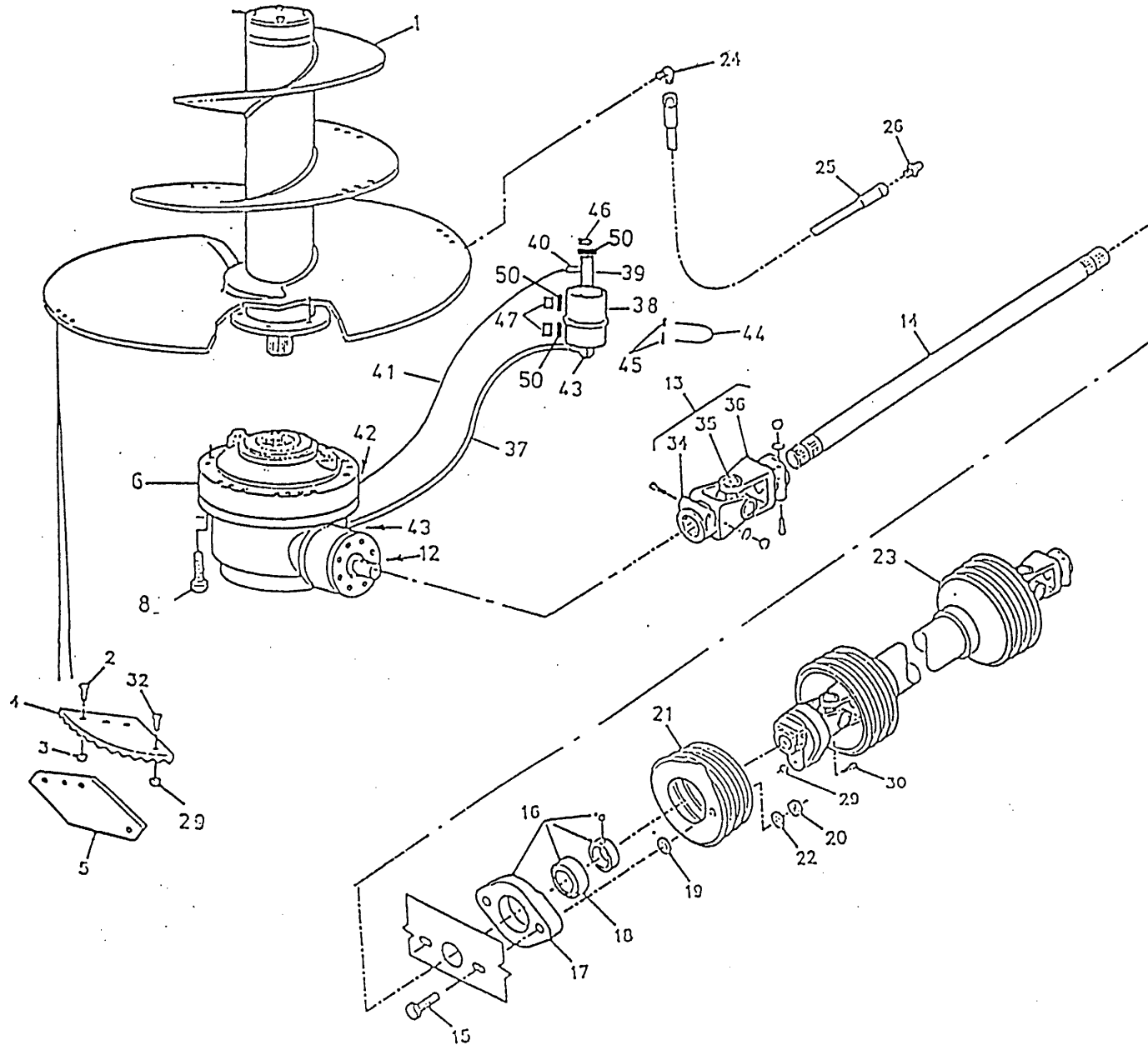

bestelnummer

ordernummer

Num. à commander

Bestellnummer

1	12104	1	
2	84120	27	M16 x 50
3	86216	27	M16
4	31639	9	
5	31640	9	
6A	90530	1	BR Ø45
6B	90651	1	BR 1 3/4-20
8	81615	13	M16 x 140
9	85116	13	M16
13A	90537	1	Ø45 - 1 3/4-6
13B	90683	1	1 3/4-20 - 1 3/4-6
14	31761	1	L=1520
15	81251	2	M12x50
16	70133	1	
17	70135	1	
18	70134	1	
19	85119	2	M12
20	86112	2	M12
21	90499	1	
22	85012	2	M12
23	90496	1	
24	50107	1	
25	50957	1	1/4" 1520 RR
26	89518	1	
29	86210	1	M10
30	81060	1	M10x60
32	84101	9	M8x20
34A	90537	1	Ø 45/14
34B	90562		1 3/4-20
35	90561	1	
36	90608	1	1 3/4-6
37	W50665	1	3/8" 1850 RH
38	90443	1	
39	50176	1	
40	50177	1	

92126/1

Afbeelding 6B : Aandrijving en Mengvijzel 14m³

Abbildung 6B : Schnecke und Antrieb 14m³

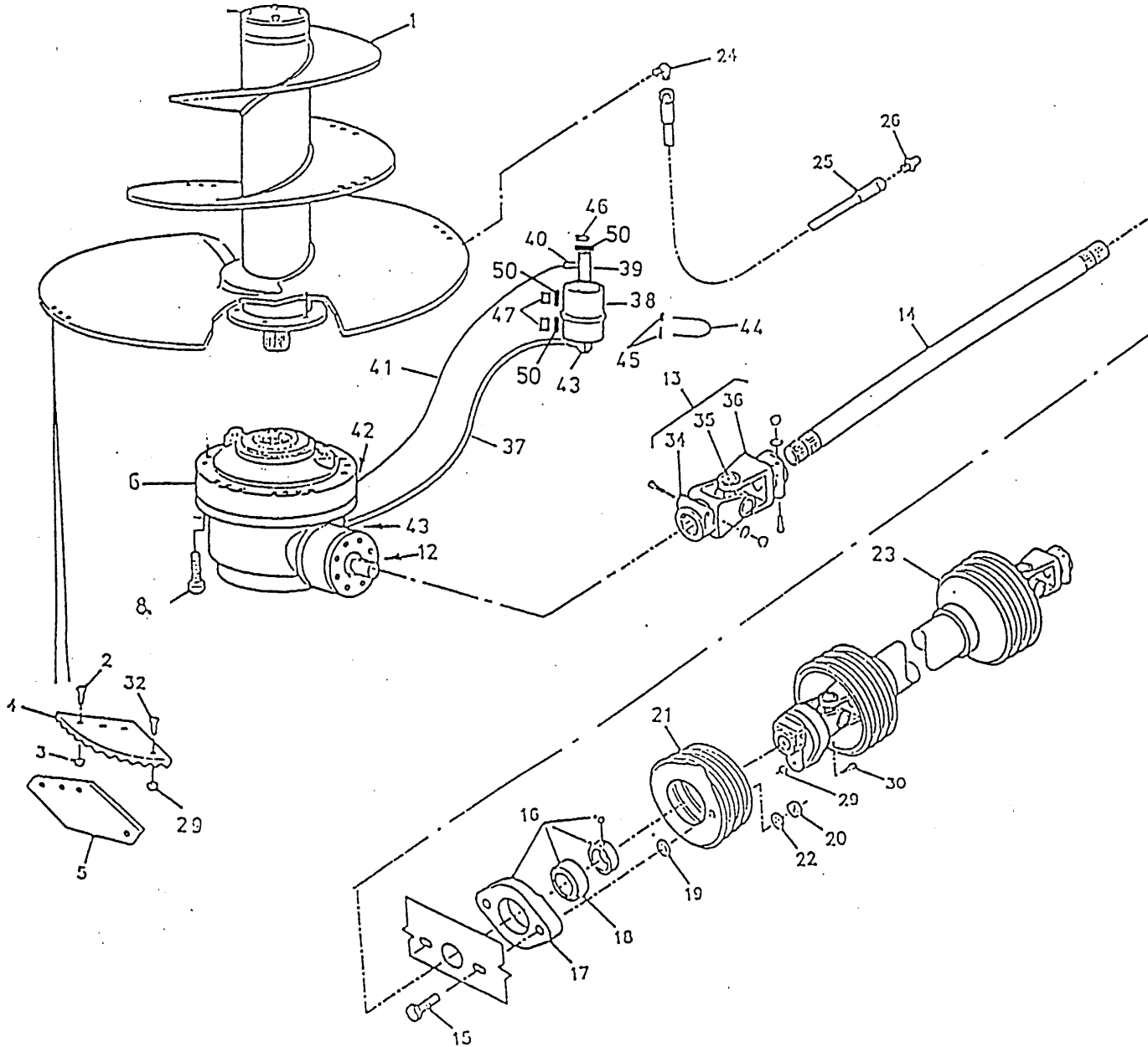

bestelnummer	ordernummer	Num. à commander	Bestellnummer
41	50950	1	
42A	50178	1	
42B	50181	1	
43	X50112	2	
44	84191	1	
45	86206	2	
46	90567	1	
47	90566	2	
50	85215	3	

92126/1

Afbeelding 7 : Snij - Laadklep

Abbildung 7 : Schneid - Ladeklappe

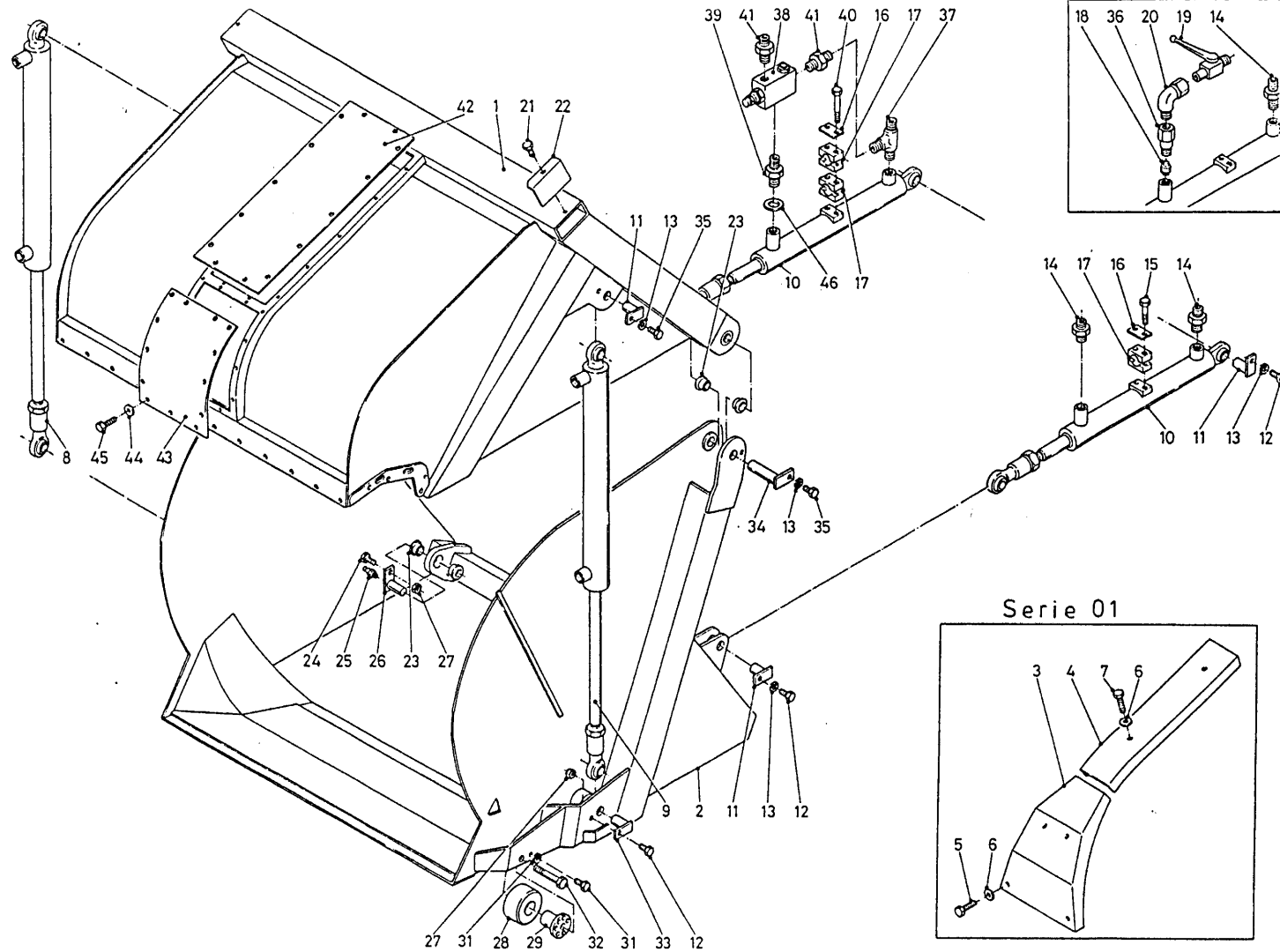

bestelnummer		ordernummer	
Num. à commander		Bestellnummer	
1A	11834	1	8m³
1B	12076	1	10m³
1C	12254	1	12m³
1D	12137	1	14m³
2A	11833	1	8m³
2B	12075	1	10m³
2C	12253	1	12m³
2D	12133	1	14m³
3A	12014	1	→I01
3B	40494	1	8m³/10m³ I→02
3C	40499	1	12m³
3D	12139	1	14m³
4A	40447	1	→I01
4B	40493	1	8m³/10m³ I→02
4C	40498	1	12m³
4D	40488	1	14m³
5	80890	4	M8 x 90
6	85108	6	M8
7	80860	2	M8 x 60
8A	51089	1	Ø 140 8m³ /10m³
8B	51140	1	Ø 140 12m³
8C	51094	1	Ø 140 14m³
9A	51090	1	Ø 150 8m³ /10m³
9B	51139	1	Ø 150 12m³
9C	51095	1	Ø 140 14m³
10A	51106	2	8m³
10B	51116	2	10m³/12m³
10C	51153	2	14m³
11	11627	6	
12	81235	6	M12 x 35
13	85012	8	M12
14	X50102	3	
15	80641	4	M6 x 40
16	90434	2	
17	90433	2	
18	53270	1	0,65mm →I01
19	51044	1	→I01
20	50103	1	→I01
21	80810	2	M8 x 10

92126/1

Afbeelding 7 : Snij - Laadklep
 Abbildung 7 : Schneid - Ladeklappe

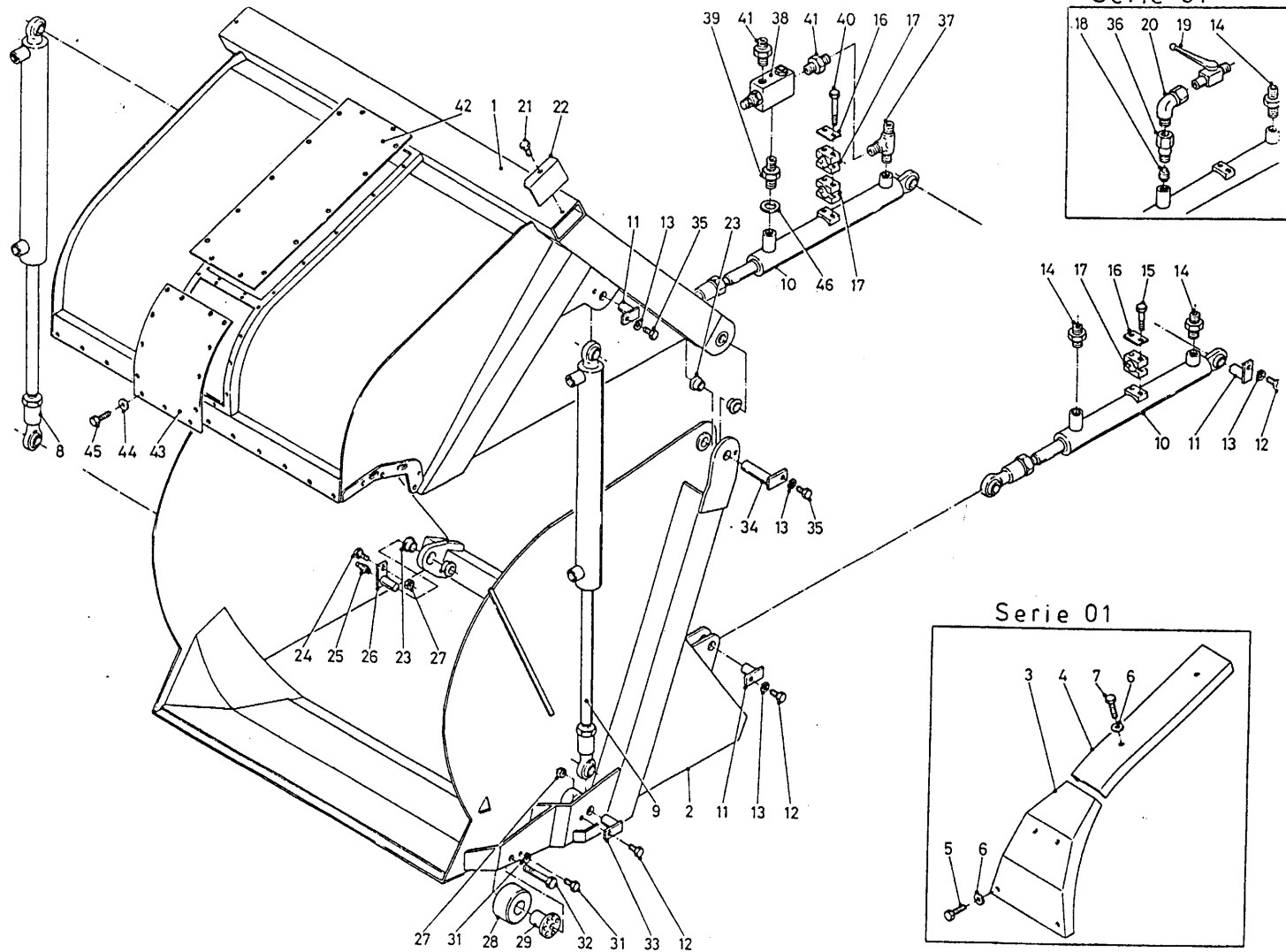

bestelnummer	ordernummer	Num. à commander	Bestellnummer
22	40446	2	8m³/10m³/14m³
22A	40501	1	12m³ Rechts
22B	40500	1	12m³ Links
23	51751	8	
24	81251	2	M12 x 50
25	89517	2	
26	11628	2	
27	86212	4	M12
28	60292	2	
29	11954	2	
30	85008	2	M8
31	80821	2	M8 x 20
32	81610	2	M16 x 100
33	12060	2	
34	11963	2	
35	81226	4	M12 x 25
36	31669	1	→I 01
37	53402	1	
38	50189	1	
39	X50116	2	
40	50310	1	

92126/1

Afbeelding 8 : Laadklepcilinder / Doseerklapcilinder
 Abbildung 8 : Ladeklappezylinder / Auswurfschieberzylinder

51106 - 51116

bestelnummer
 ordernummer
 Num. à commander
 Bestellnummer

51106 8m³

1	11972	1	
2	31698	1	
3	86140	1	M40 x 2
4	11671	1	
5	30909	1	
6	31446	1	
7	84119	1	M6 x 10
8	53270	1	0,65 mm
X	05296	1	

51116 10m³/12m³

1	11972	1	
2	31779	1	
3	86140	1	M40 x 2
4	11671	1	
5	30909	1	
6	31446	1	
7	84119	1	M6 x 10
8	53270	1	
X	05296	1	

51062

1	11600	1	
2	30860	1	
3	31460	1	
4	31459	1	
X	05317		

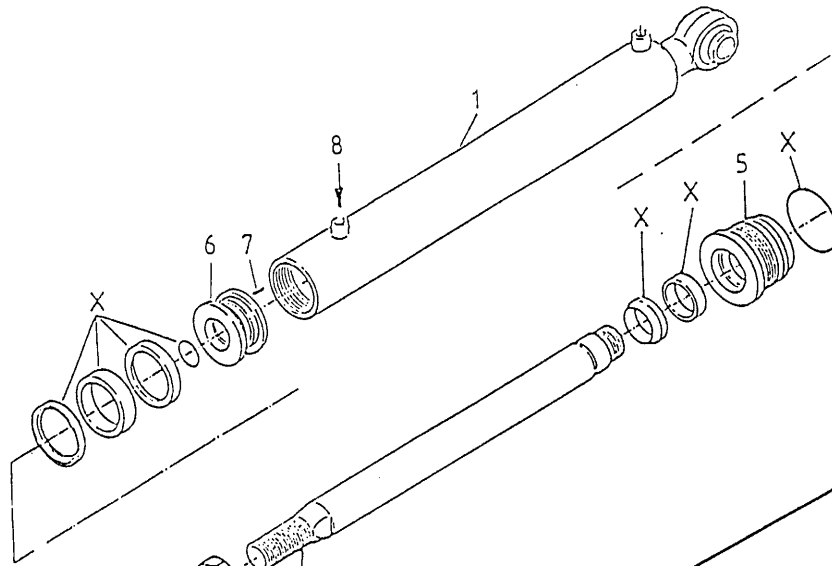

51062

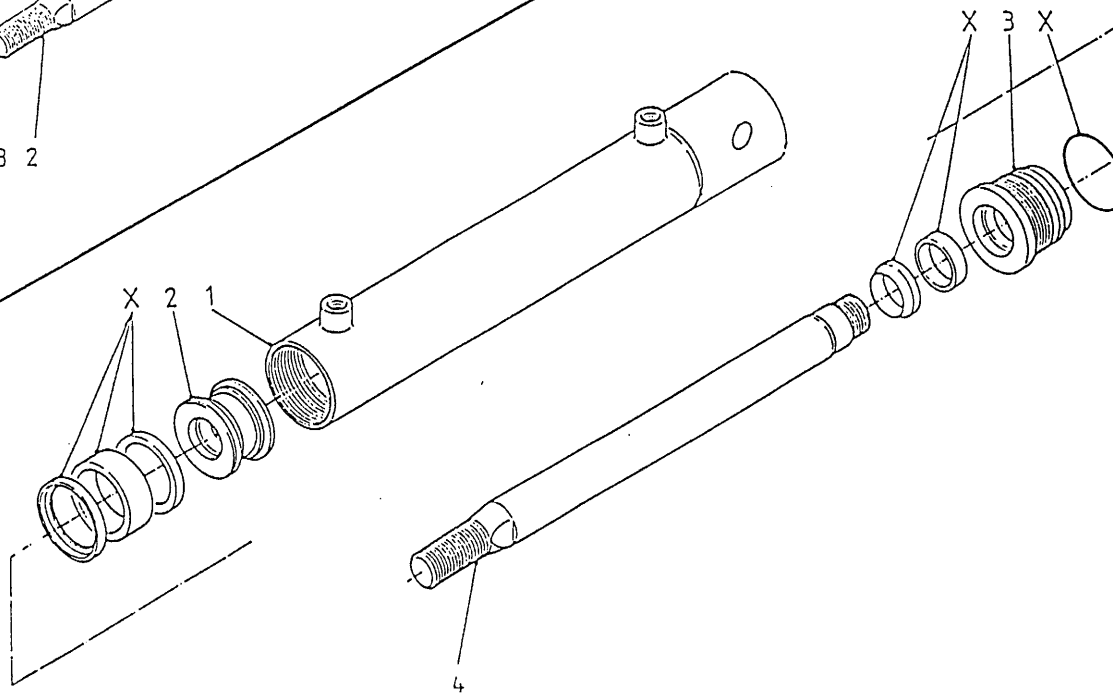

92126/1

Afbeelding 9 : Mastercilinder / Slavecilinder
 Abbinging 9 : Masterzylinder / Slavezylinder

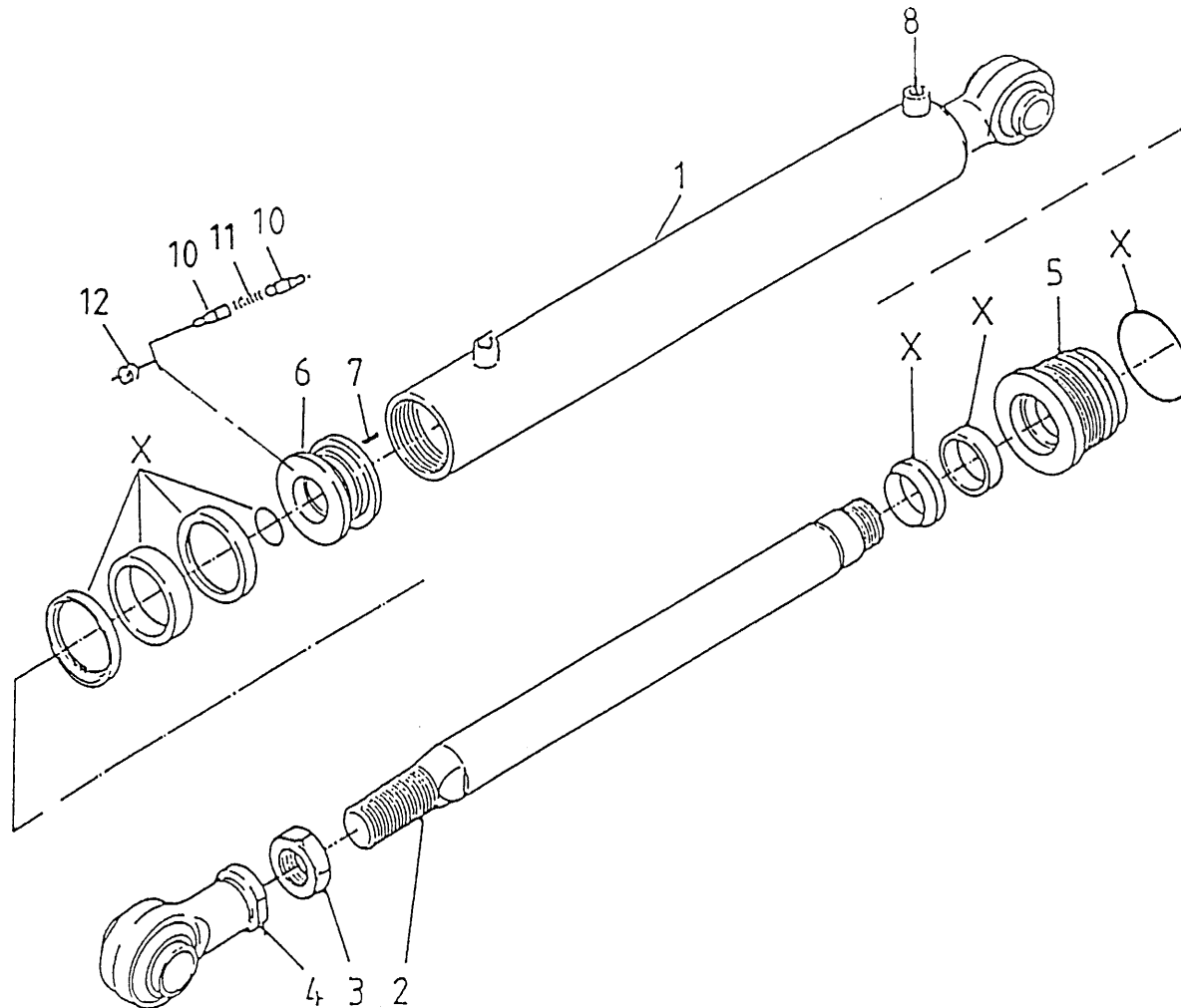

bestelnummer
 ordernummer
 Num. à commander
 Bestellnummer

Master 51089/ 51139/ 51094

1A	11870	1	Ø 140 8m ³ -10m ³
1B	12239	1	Ø 140 12m ³
1C	11872	1	Ø 140 14m ³
2A	31563	1	8m ³ -10m ³
2B	31855		12m ³
2C	31659		14m ³
3	86140	1	M40 x 2
4	11671	1	
5	31559	1	
6	31558	1	
7	84119	1	M6 x 10
8	53173	1	Ø 2 mm
10	31277	2	
11	65062	1	
12	30870	1	
X	05334	1	

Slave 51090/ 51140/ 51095

1A	11871	1	Ø 150 8m ³ 10m ³ -
1B	12240	1	Ø 150 12m ³
1C	11873	1	Ø 150 14m ³
2A	31563	1	8m ³ -10m ³
2B	31855	1	12m ³
2C	31659	1	14m ³
3	86140	1	M40 x 2
4	11671	1	
5	31565	1	
6	31564	1	
7	84119	1	M6 x 10
8	53173	1	Ø 2 mm
10	31270	2	
11	65062	1	
X	05335		

92126/1

Afbeelding 10 : Snijsysteem
 Abbildung 10 : Schneidvorrichtung

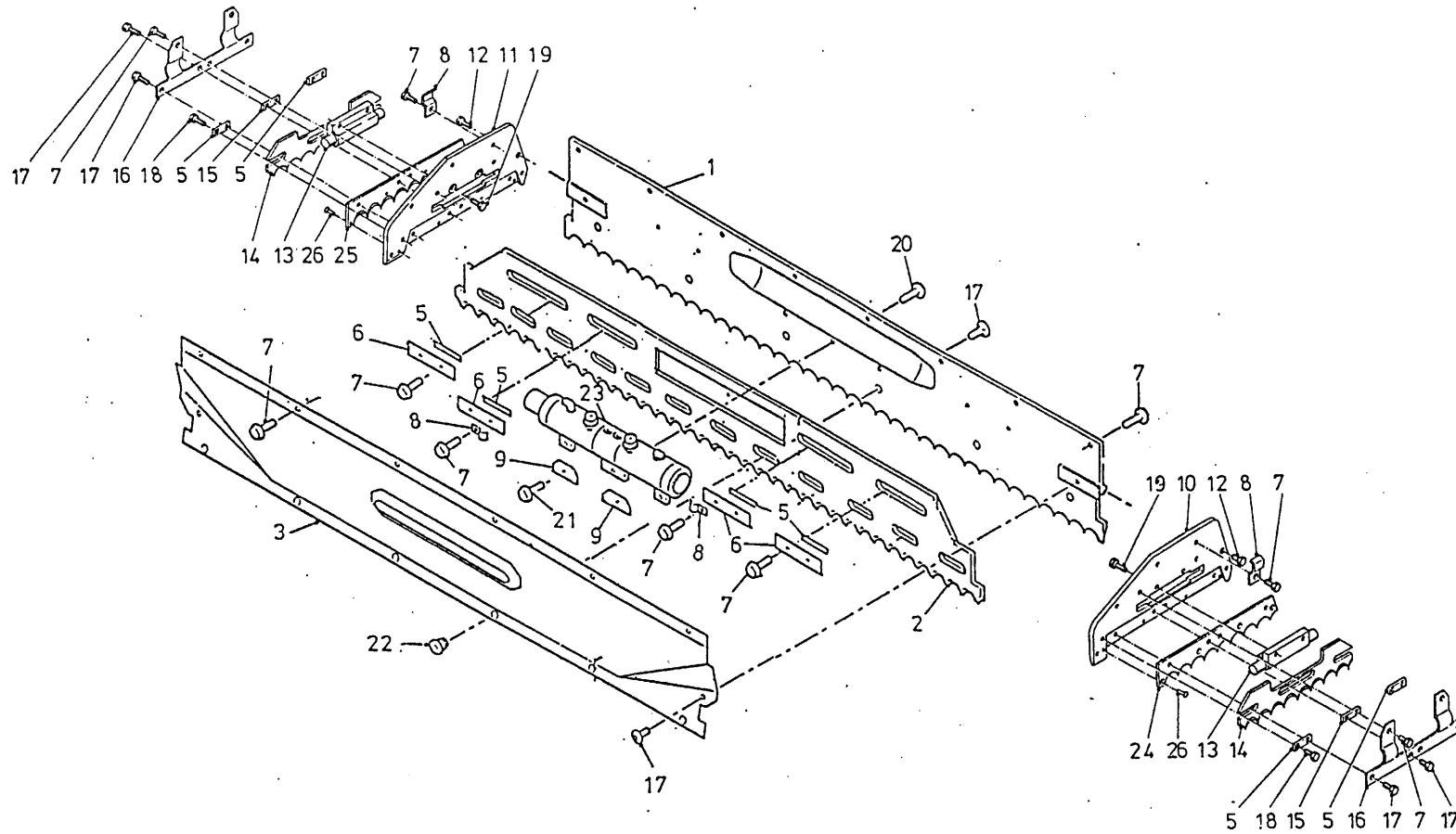

bestelnummer
 ordernummer
 Num. à commander
 Bestellnummer

1A	11836	1	8m ³
1B	12079	1	10m ³ -12m ³
1C	12171	1	14m ³
2A	24907	1	8m ³
2B	25736	1	10m ³ -12m ³
2C	25873	1	14m ³
3A	11839	1	8m ³
3B	12080	1	10m ³ -12m ³
3C	12142	1	14m ³
4	51078	1	
5	25636	8	
6	25637	4	
7	83916	44	M10 x 16
8	24153	4	
9	25624	2	
10A	12031	1	→I01
10B	12155	1	I→02
11A	12032	1	→I01
11B	12156	1	I→02
12	83937	2	M12x30
13	51115	2	
14	24263	2	
15	25638	2	
16	24266	2	
17	84926	22	M10 x 19
18	84802	4	M10 x 20
19	83921	4	M10 x 25
20	83923	4	M12 x 20
21	83920	2	M10 x 20
24	26066	1	
25	26067	1	
26	85201	4	Ø 5x12

92126/1

Afbeelding 11 : Slangen snijbord
 Abbildung 11 : Schläuche Schneidschild

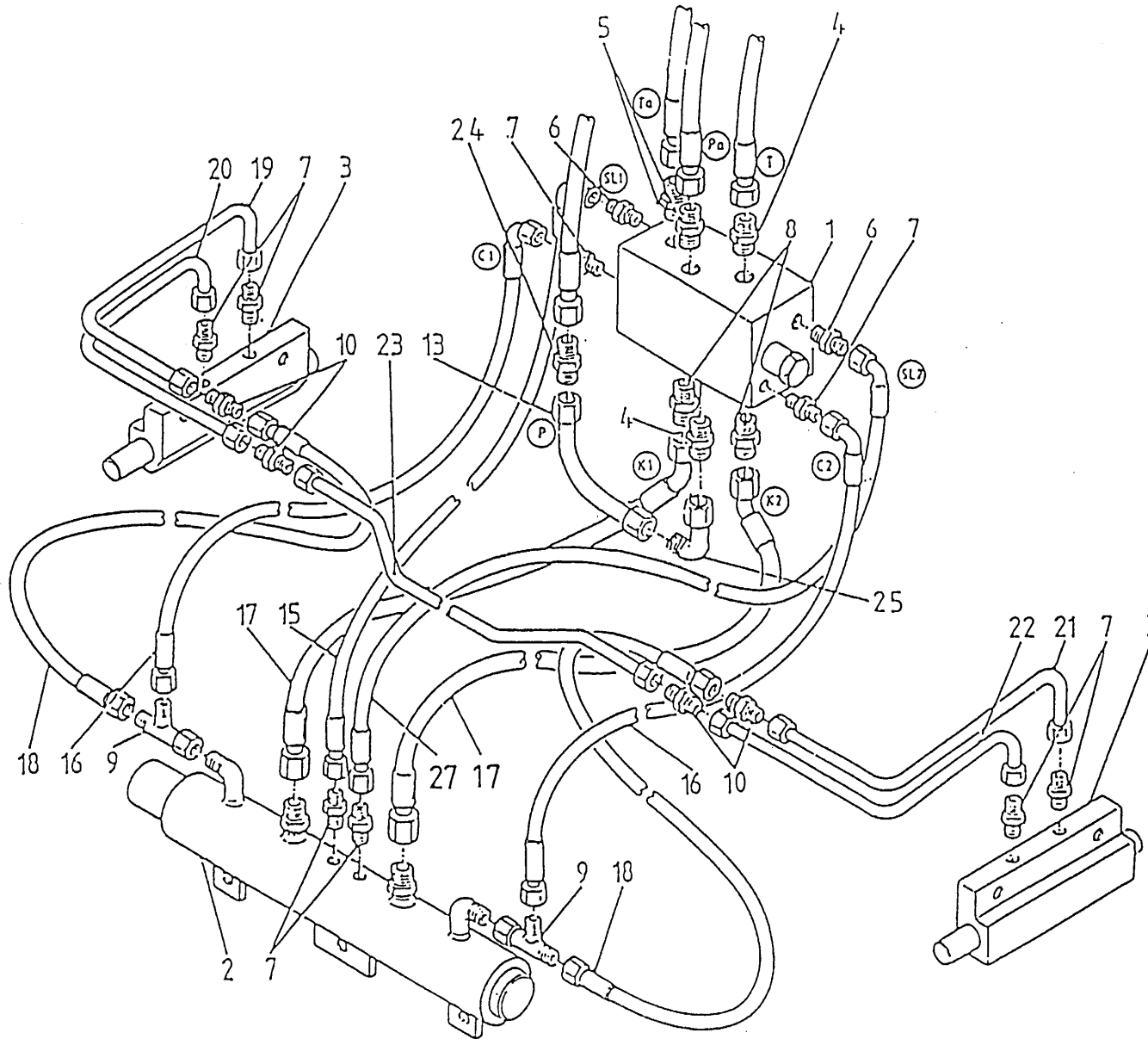

bestelnummer
 ordernummer
 Num. à commander
 Bestellnummer

1	53198	1	
2	51078	1	Ø 50,8
3	51115	2	
4	X50138	2	
5	X50113	2	
6	X50114	2	
7	X50104	8	
8	X50102	2	
9	X50300	2	
10	X50135	4	
13	50909	1	
15	W50971	1	¼" 400 H20°
16	W50895	2	¼" 300 RH
17	W50970	2	½" 290 R45°
18	W50896	1	¼" 460 RR
19A	50955	1	8m³
19B	50966	1	10m³/12m³
19C	50981	1	14m³
20A	50954	1	8m³
20B	50967	1	10m³/12m³
20C	50982	1	14m³
21A	50953	1	8m³
21B	50968	1	10m³/12m³
21C	50983	1	14m³
22A	50952	1	8m³
22B	50969	1	10m³
22C	50984	1	14m³
23	50890	1	
24	X50162	1	
25	X50418	1	
27	W50972	1	¼" 400 H20°

92126/1

Afbeelding 12 : Stuurblok inwendig

Abbildung 12 : Steuerblock Innenseite

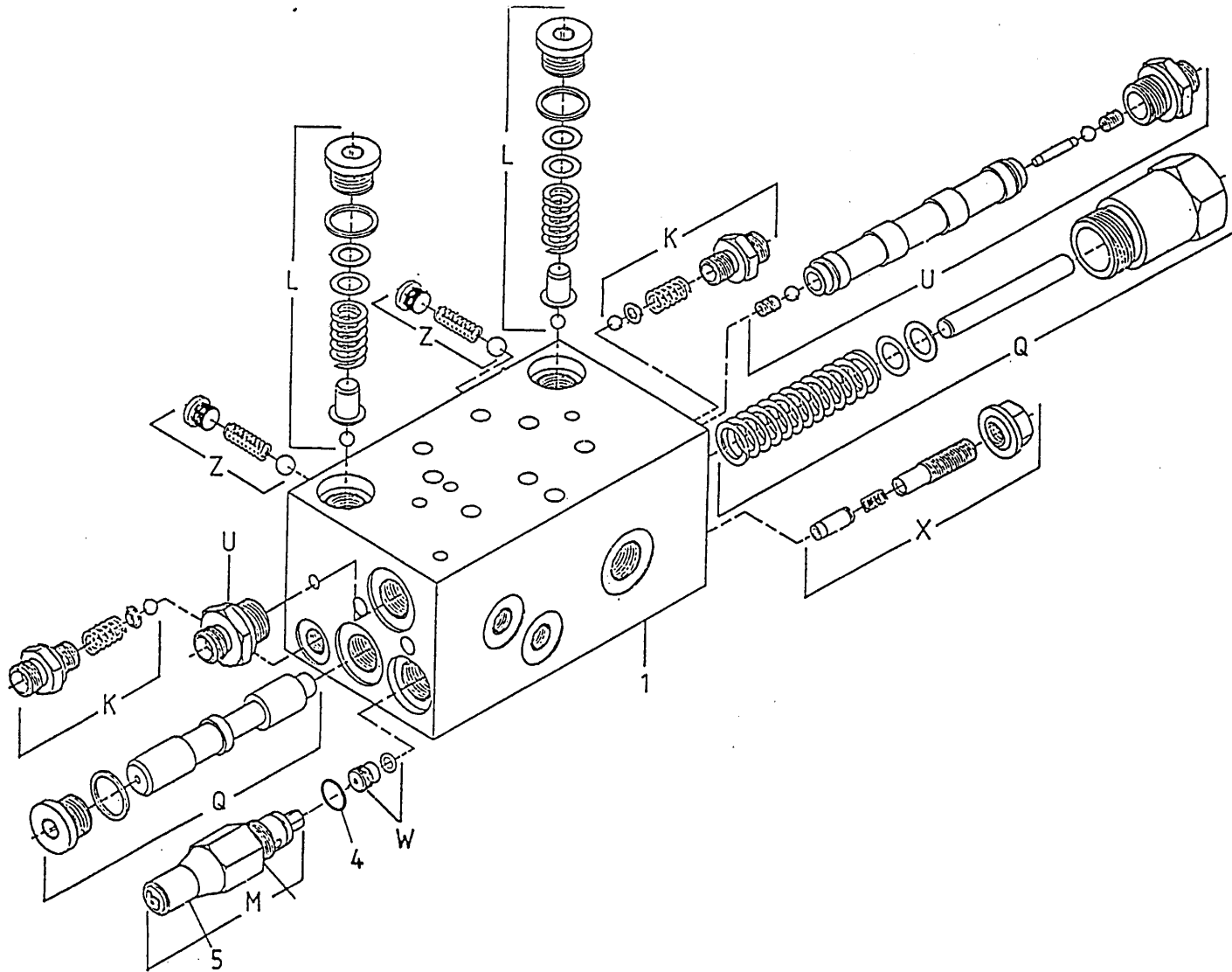

bestelnummer
 ordernummer
 Num. à commander
 Bestellnummer

1	53198	1
4	78053	1 12 X 1,5
5	60260	1
K	05049	2 10 bar
L	05264	2 200 bar
M	05265	1 230 bar
U	53150	1
W	53257	1
Z	05052	2

93126/1

Afbeelding 13 : Achter- en zijmescilinder

Abbildung 13 : Heck- und Seitenzylinder

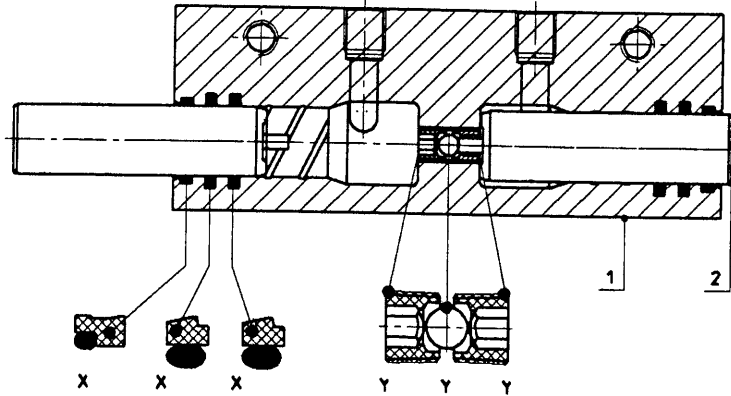
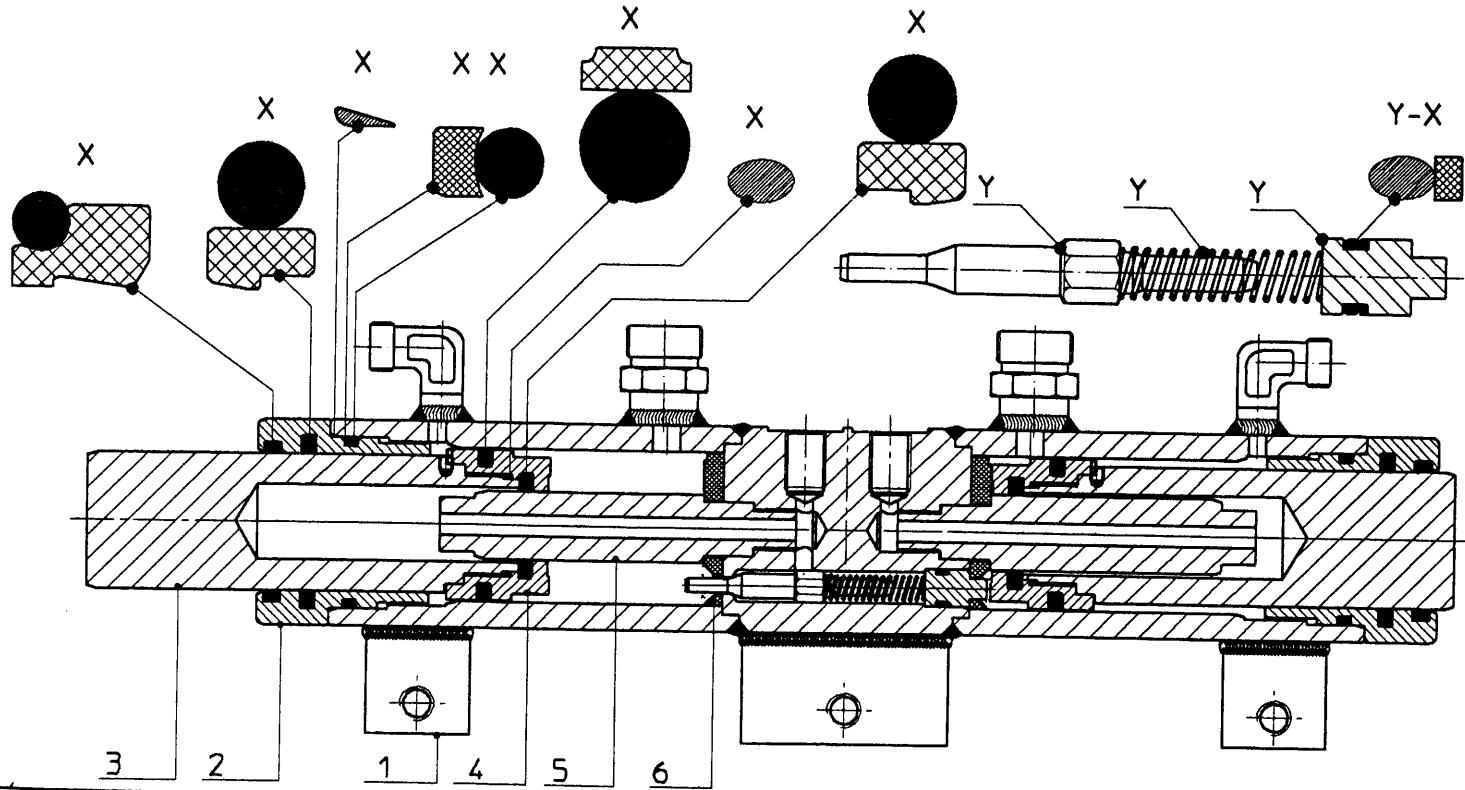

bestelnummer
ordernummer
Num. à commander
Bestellnummer

51078

1	11744	1	Ø 50,8
2	31568	1	
3	31573	1	
4	31572	1	
5	31417	1	
6	31569	1	
X	05313	1	
Y	05370	1	

51115

1	31772	1
2	31436	2
X	05294	1
Y	05298	1

92126/1

Afbeelding 14 : Gelijkloopbewakingssysteem
 Abbildung 14 : Synchronlaufüberwachungssystem

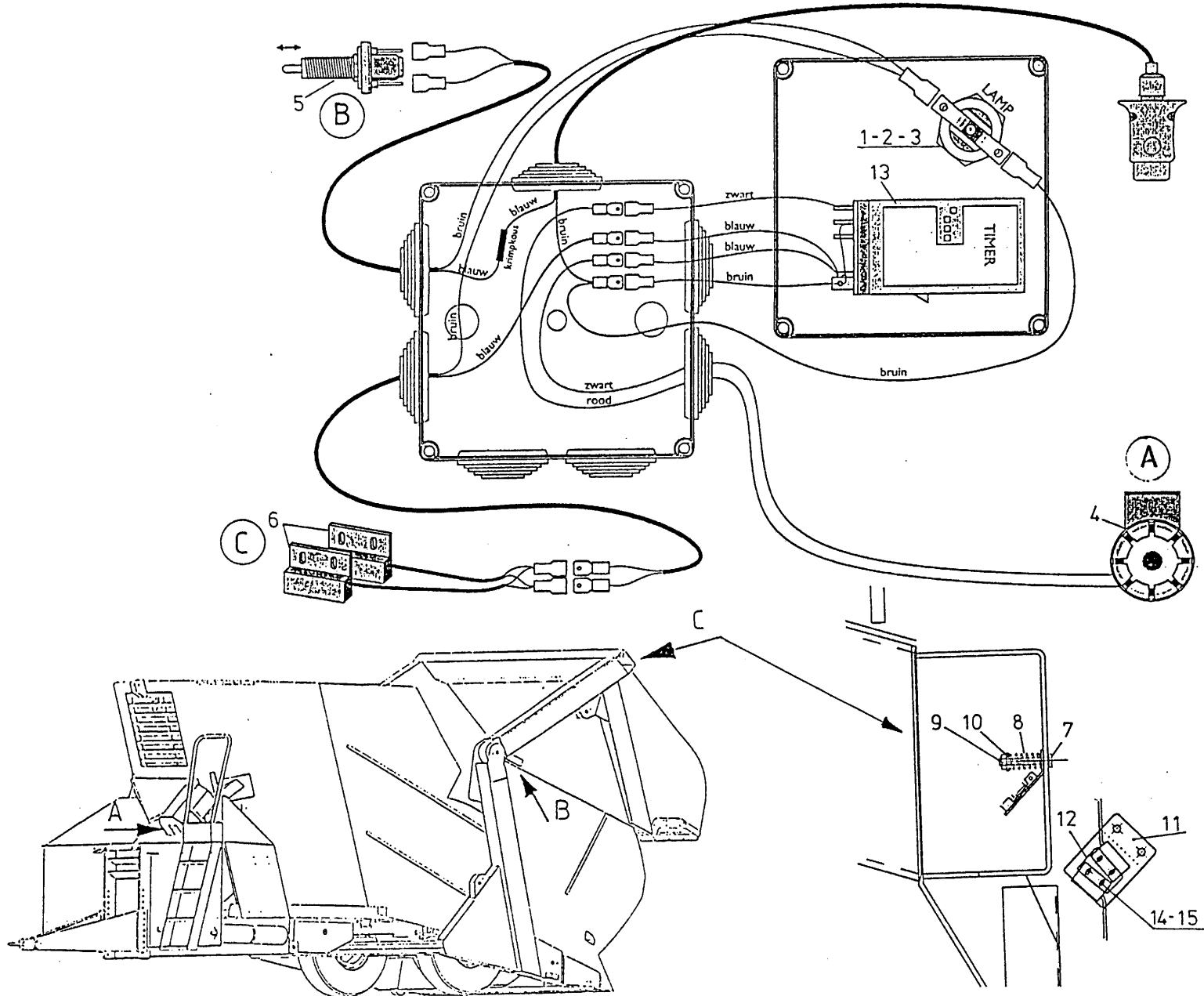

bestelnummer
 ordernummer
 Num. à commander
 Bestellnummer

1	98179	1	
2	98181	1	
3	98122	1	
4	98170	1	
5	98168	1	
6	98169	1	
7	80645	2	M6 x 45
8	65033	2	
9	86206	2	M6
10	85107	2	M6
11	40495	1	
12	40496	1	
13	98176	1	
14	80320	4	M3x20
15	86103	4	M3

92126/1

Afbeelding 15 : Mechanische bediening
 Abbildung 15 : Mechanische Fernbedienung

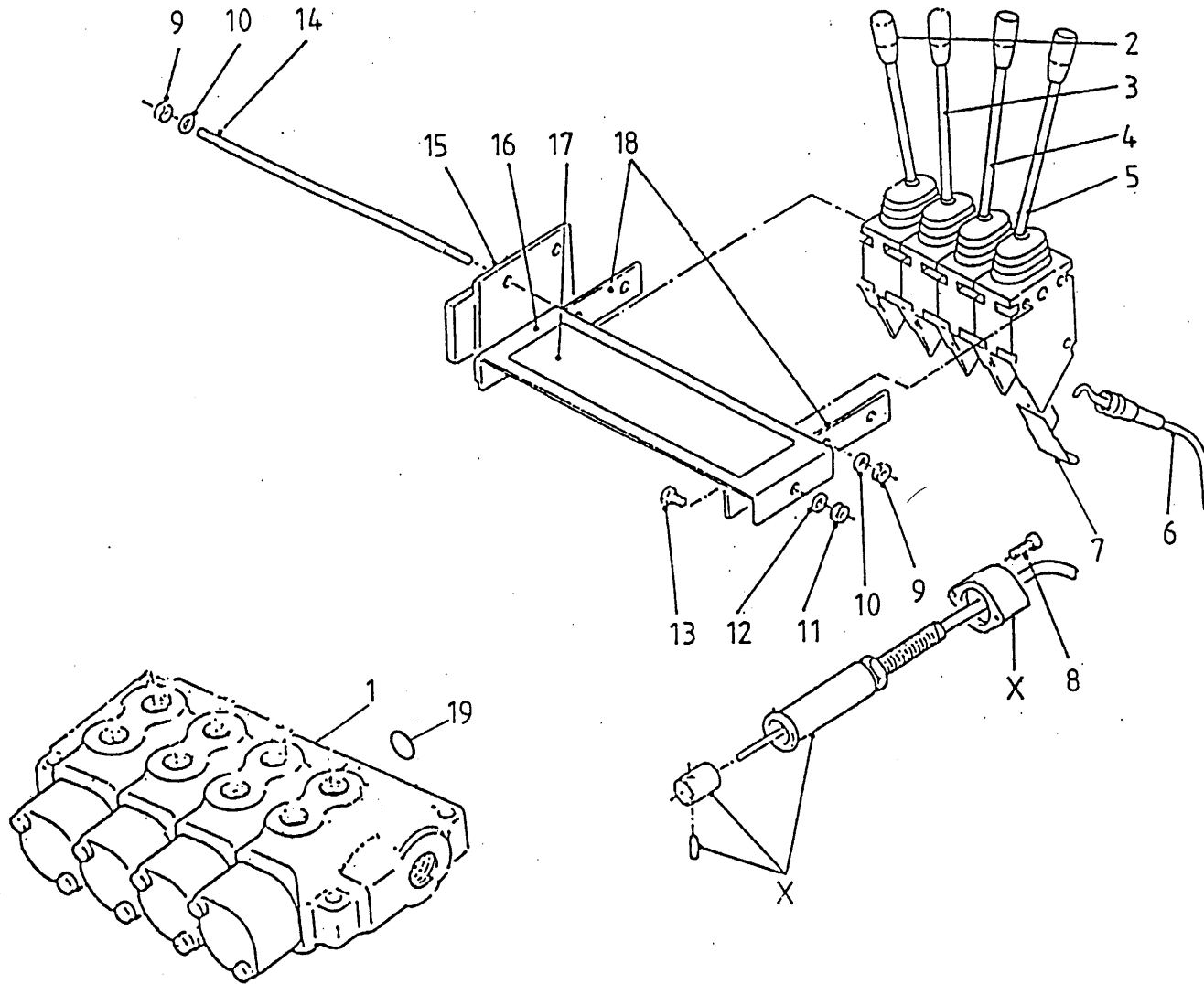

bestelnummer			
ordernummer			
Num. à commander			
Bestellnummer			
1A	53264	1	→I01
1B	53291	1	I→02
2	53128	1	30° R
3	53127	1	15° R
4	53129	1	15° L
5	53130	1	30° L
6A	79060	4	L = 3000
6B	79086	4	L = 3500
7	60210	4	
8	84480	8	M6 x 45
9	86206	6	M6
10	85106	6	M6
11	86208	2	M8
12	85108	2	M8
13	80816	2	M8 x 16
14	84043	3	M6 x 200
15	11139	1	
16	23168	1	
17	91239	1	
18	22244	2	
19	79095	4	
X	53231	1	

92126/1

Afbeelding 16 : Elektrische bediening

Abbildung 16 : Elektrische Fernbedienung

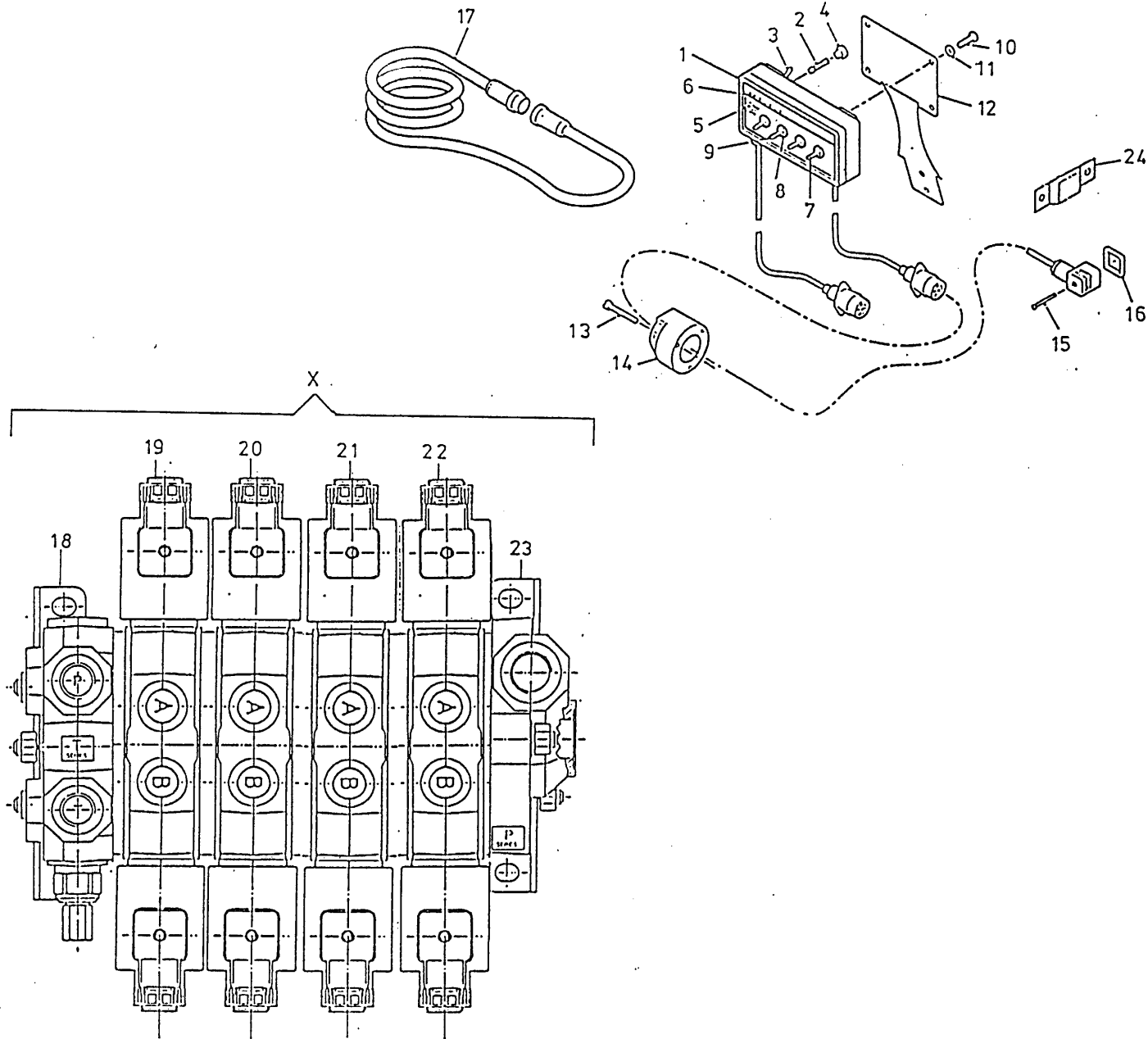

bestelnummer
ordernummer
Num. à commander
Bestellnummer

1A	98164	1	Kompl.
1B	98166	1	Leeg
2	98053	1	
3	98054	1	
4	98052	1	
5	98051	1	
6	91015	1	
7	98056	1	
8	98055	4	
9	98061	1	
10	80610	4	M6 x 10
11	85106	4	M6
12	40420	1	
13	84476	3	M5 x 30
14	98147	1	
15	84711	8	M3 x 35
16	60180	8	
17	98150	1	
18	53283	1	
19	53277	1	
20	53278	1	
21	53286	1	
22	53280	1	
23	53284	1	
24	24644	1	
X	53276	1	

92126/1

Afbeelding 17 : Elektronische Weeginstallatie

Abbildung 17 : Electronische Waage

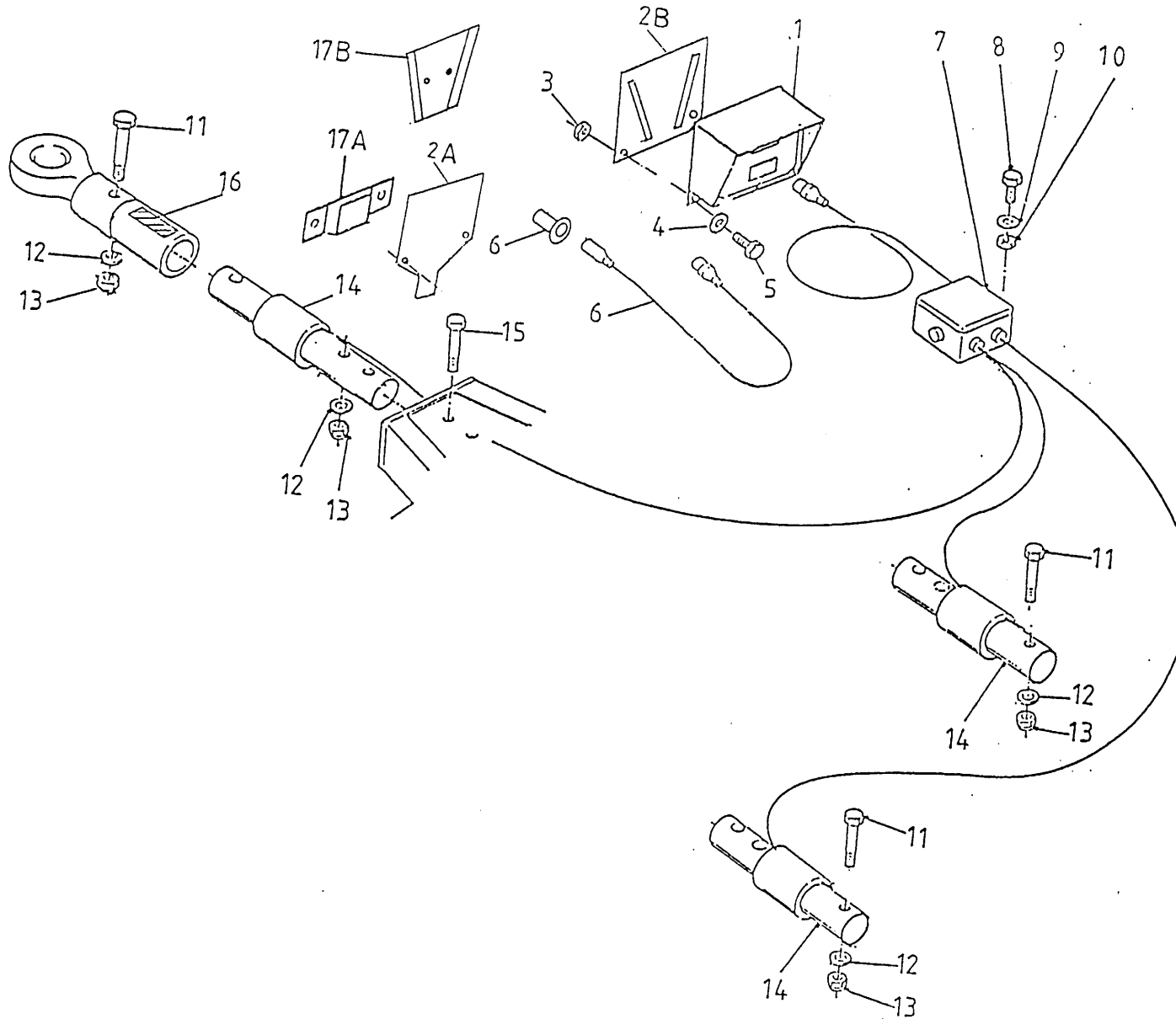

bestelnummer
ordernummer
Num. à commander
Bestellnummer

1	90481	1	
2A	40471	1	→I01
2B	40503	1	I→02
3	86506	2	M6
4	85106	2	M6
5	80621	2	M6 x 20
6	90483	1	
7	90482	1	
8	84445	4	M5 x 20
9	85105	4	M5
10	86505	4	M5
11	82013	5	M20 x 130
12	85020	6	M20
13	86220	6	M20
14	90447	3	
15	82014	1	M20 x 140
16	91216	1	
17A	24644	1	→I01
17B	40504	1	I→02

92126/1

Afbeelding 18 : Vertragingkast 8m³-10m³-12m³

Abbildung 18 : Untersetzungsgetriebe 8m³-10m³-12m³

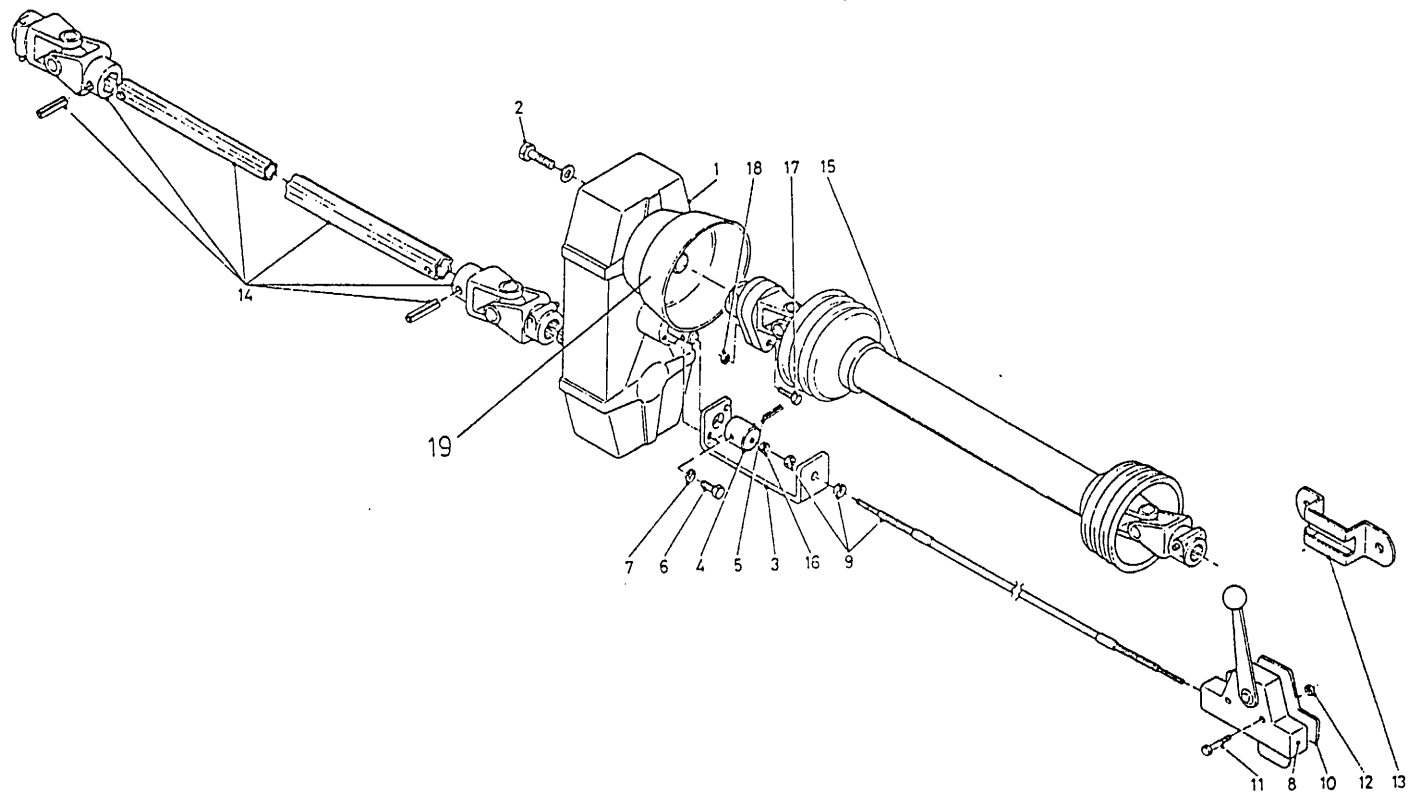

bestelnummer
 ordernummer
 Num. à commander
 Bestellnummer

1	90488	1	
2	81445	4	M14 x 45
3	25775	1	
4	31781	1	
5	88027	1	Ø6 x 26
6	80831	2	M10 x 30
7	85008	2	M10
8	79051	1	L = 3000
9	90121	1	
10	10525	1	
11	80630	2	M6 x 30
12	86206	2	M6
13	20199	1	
14A	90559	1	Ø48 - 1 3/4-6
14B	90627	1	1 3/8 - 1 3/4-6
14C	90560	1	1 3/4-20 - 1 3/4-6
15	90495	1	
17	80860	1	M8 x 60
18	86208	1	M8
19	90499	1	

92126/1

Afbeelding 19 : Hydraulische bediening conframes
 Abbildung 19 : Hydraulische Fernbedienung

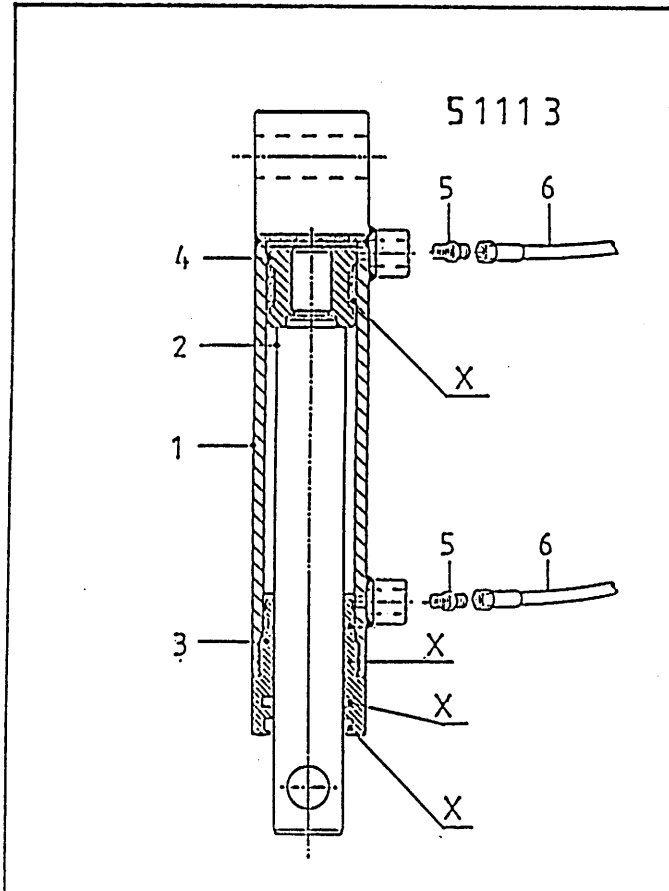
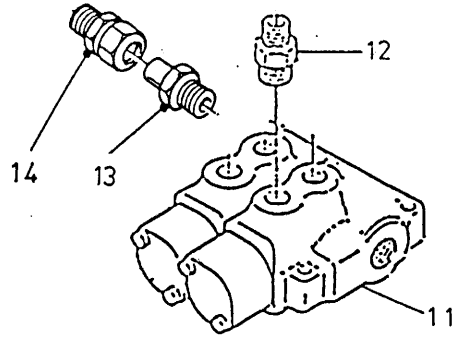
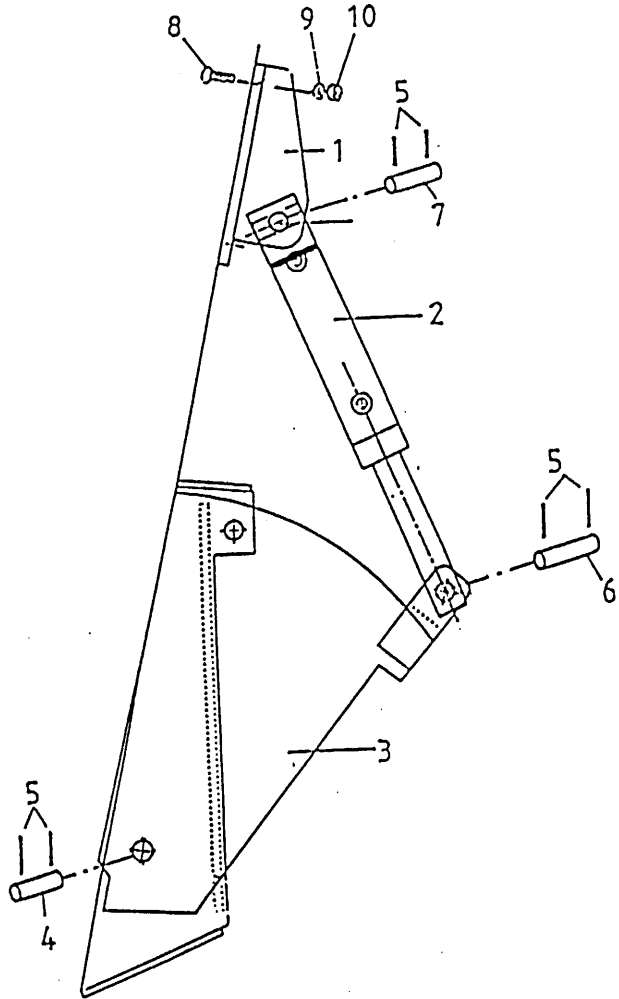

bestelnummer			
ordernummer			
Num. à commander			
Bestellnummer			
1	12043	1	
2	51113	1	
3	12039	1	
4	25332	1	
5	88239	6	Ø5 x 40
6	25607	1	
7	25606	1	
8	84808	2	M12 x 30
9	85112	2	M12
10	86212	2	M12
11	53267	1	
12	X50114	2	
13	50132	1	
14	50102	1	

51113

1	12028	1	
2	31757	1	
3	31460	1	
4	30860	1	
5	X50104	1	
6	W50959	2	¼" 4000 RH
X	05309	2	

92126/1

Afbeelding 20 : Hydraulische steunpoot

Abbildung 20 : Hydraulischer Stützfuß

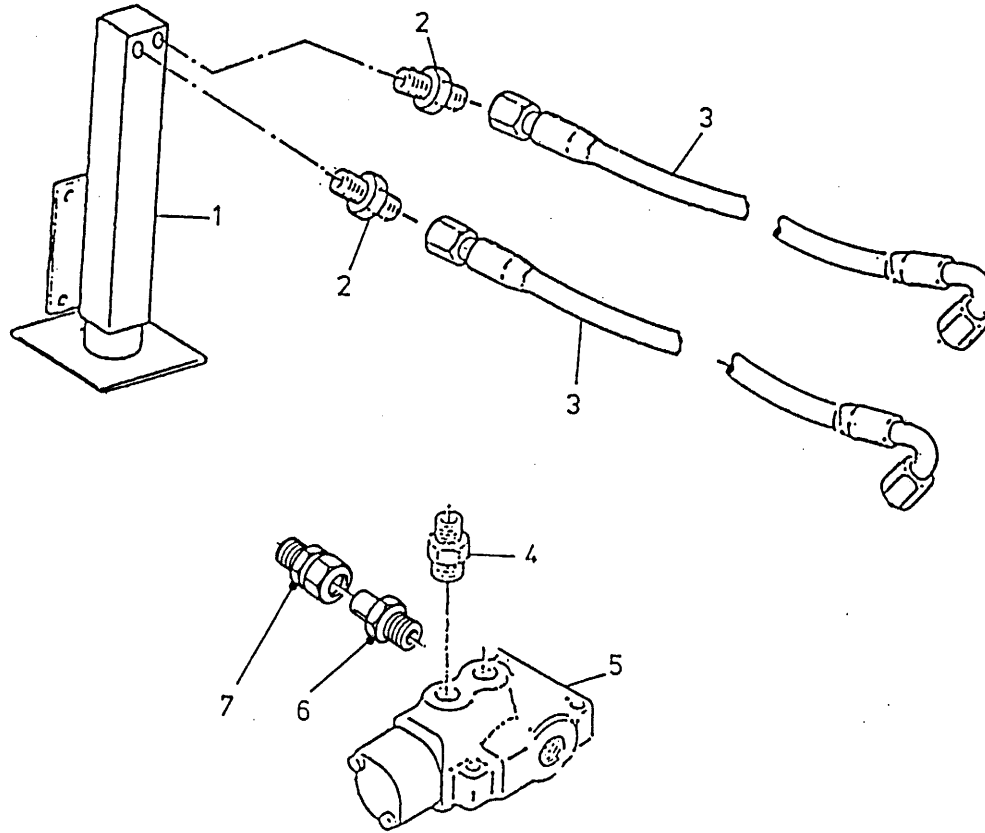

bestelnummer
ordernummer
Num. à commander
Bestellnummer

1	12029	1	
2	X50124	2	
3	W50956	2	¼" 4200 RH
4	X50114	2	
5	53002	1	
6	50132	1	
7	50102	1	

92126/1

Afbeelding 21 : Slangenschema mechanische bediening

Abbildung 21 : Schaltplan Mechanische Fernbediening

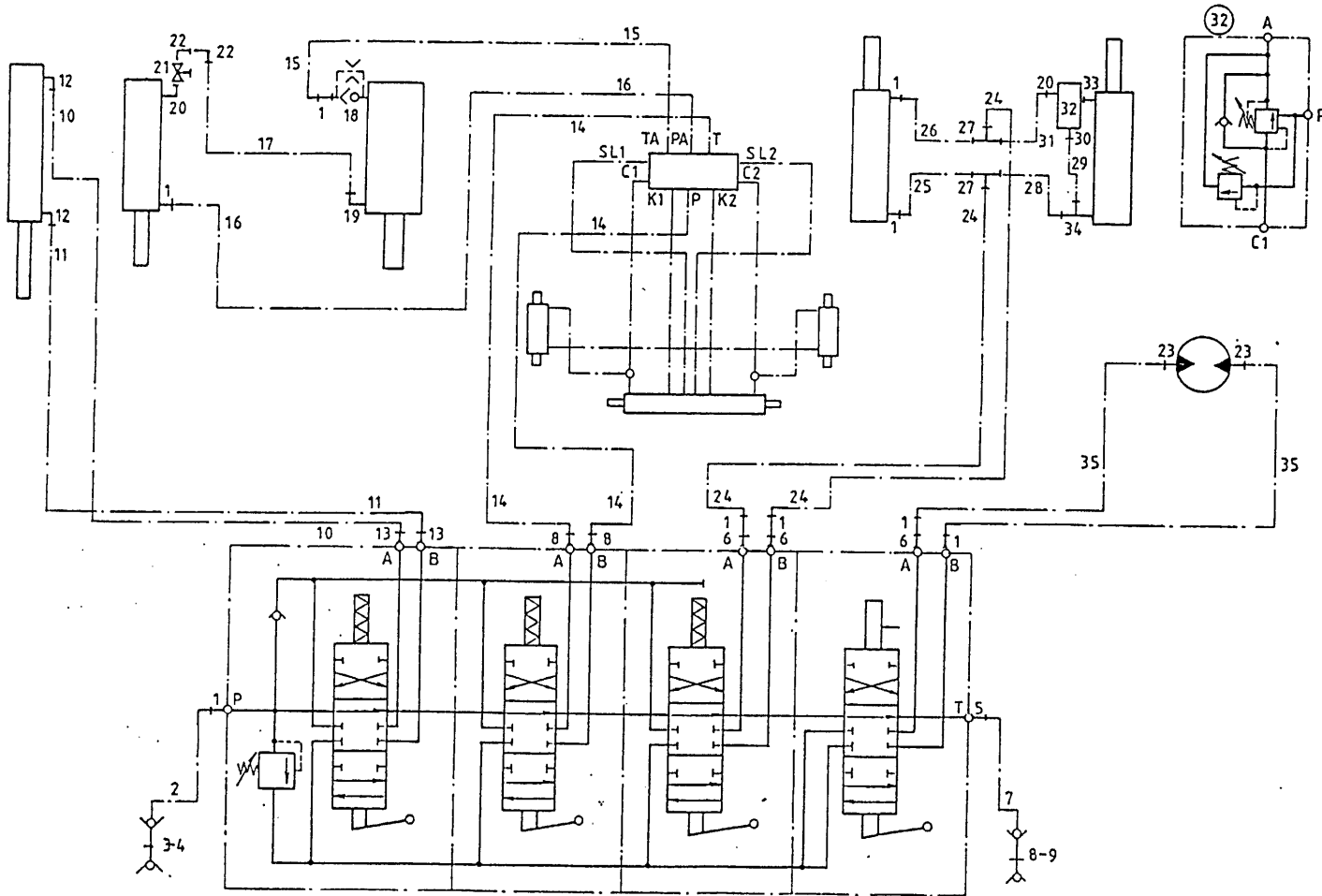

bestelnummer		ordernummer	
Num. à commander		Bestellnummer	
1	X50102	1	
2	W50768	1	½" 3000 RH
3	53303	1	
4	53301	1	
5	X50138	3	
6	50133	3	
7	W50738	1	⅝" 3000 RH
8	53315	1	
9	53326	1	
10	W50700	1	¼" 1800 RH
11	W50650	1	¼" 1000 RH
12	X50107	2	
13	X50114	2	
14A	W50965	2	8m³ ⅝" 7150 RH
14B	W50980	2	10m³ ⅝" 7400 RH
14C	W52601	2	12m³ ⅝" 7800 RH
14D	W52600	2	14m³ ⅝" 8650 RH
15A	W50846	1	8m³ ½" 3250 RH
15B	W50977	1	10m³/12m³ ½" 3350 RH
15C	W50921	1	14m³ ½" 3800 RH
16A	W50901	1	8m³ ½" 4770 RH
16B	W50975	1	10m³/ ½" 4870 RH
16C	W50789	1	12m³ ½" 5150 RR
16D	W52602	1	14m³ ½" 6000 RR
17A	W50789	1	8m³ ½" 5150 RR
17B	W50999	1	10m³ ½" 5400 RR
17C	W52612	1	12m³ ½" 5600 RR
17D	W52602	1	14m³ ½" 6000 RR
18	53192	1	
19	X50101	1	
20	50103	1	
21	51044	1	
22	X50143	2	
23	X50117	2	
24	W50825	2	½" 1600 RH
25	W50726	1	½" 2000 RH
26	W50725	1	½" 2600 RH
27	X50357	2	
28B	W50973	1	10m³/12m³ ½" 400 RH
28C	W50688	1	14m³ ½" 600 RH

92126/1

Afbeelding 21 : Slangenschema mechanische bediening

Abbildung 21 : Schaltplan Mechanische Fernbediening

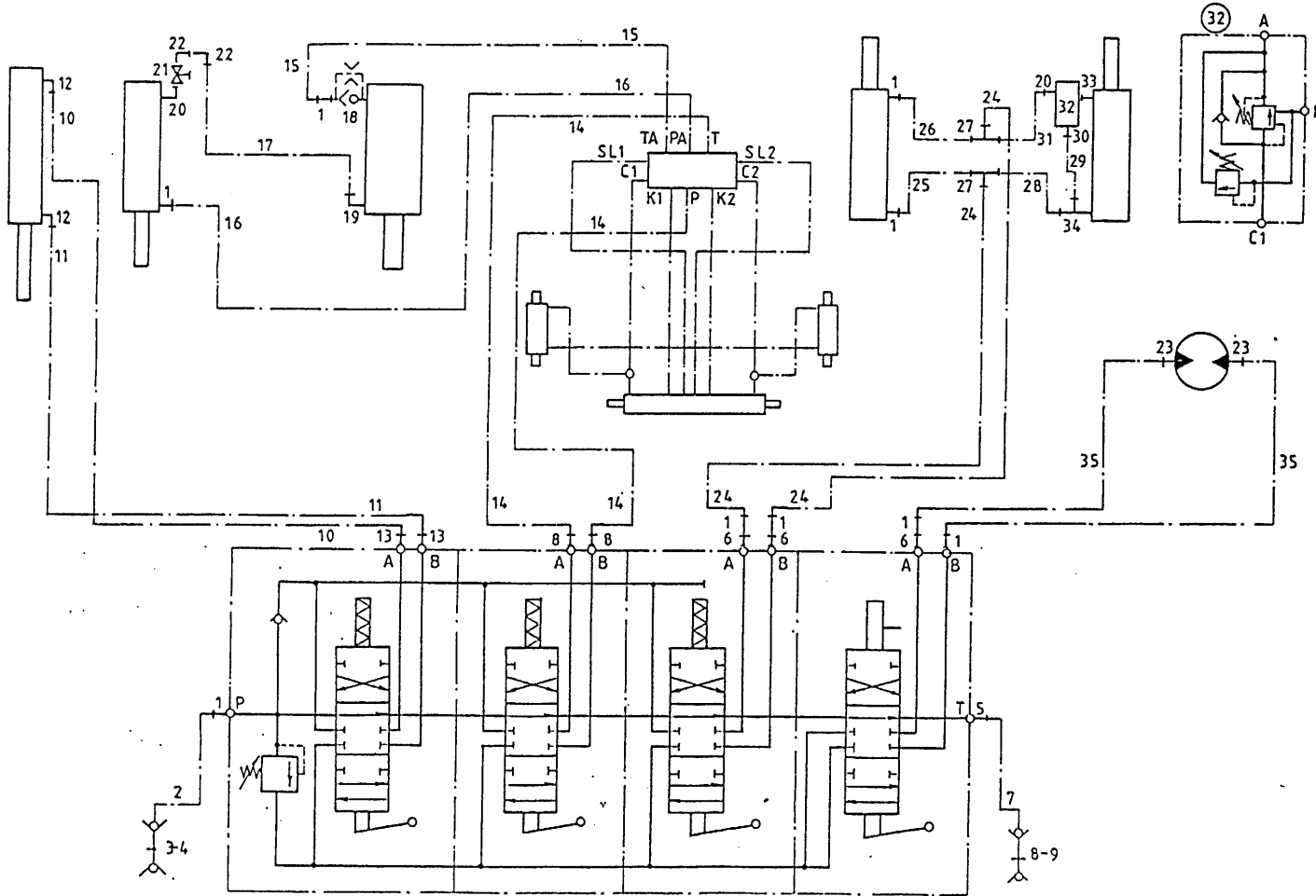

bestelnummer
 ordernummer
 Num. à commander
 Bestellnummer

29	W50747	1	½" 650 RR
30	X50116	2	
31A	W50998	1	8m³/10m³/12m³ ½"1050 RH
31B	W50819	1	14m³ ½"1250 RH
32	53402	1	
33	50189	1	
34	50310	1	
35	W50602	2	½" 3500 RH

92126/1

Afbeelding 22 : Slangenschema elektrische bediening

Abbildung 22 : Schaltplan Elektrische Fernbedienung

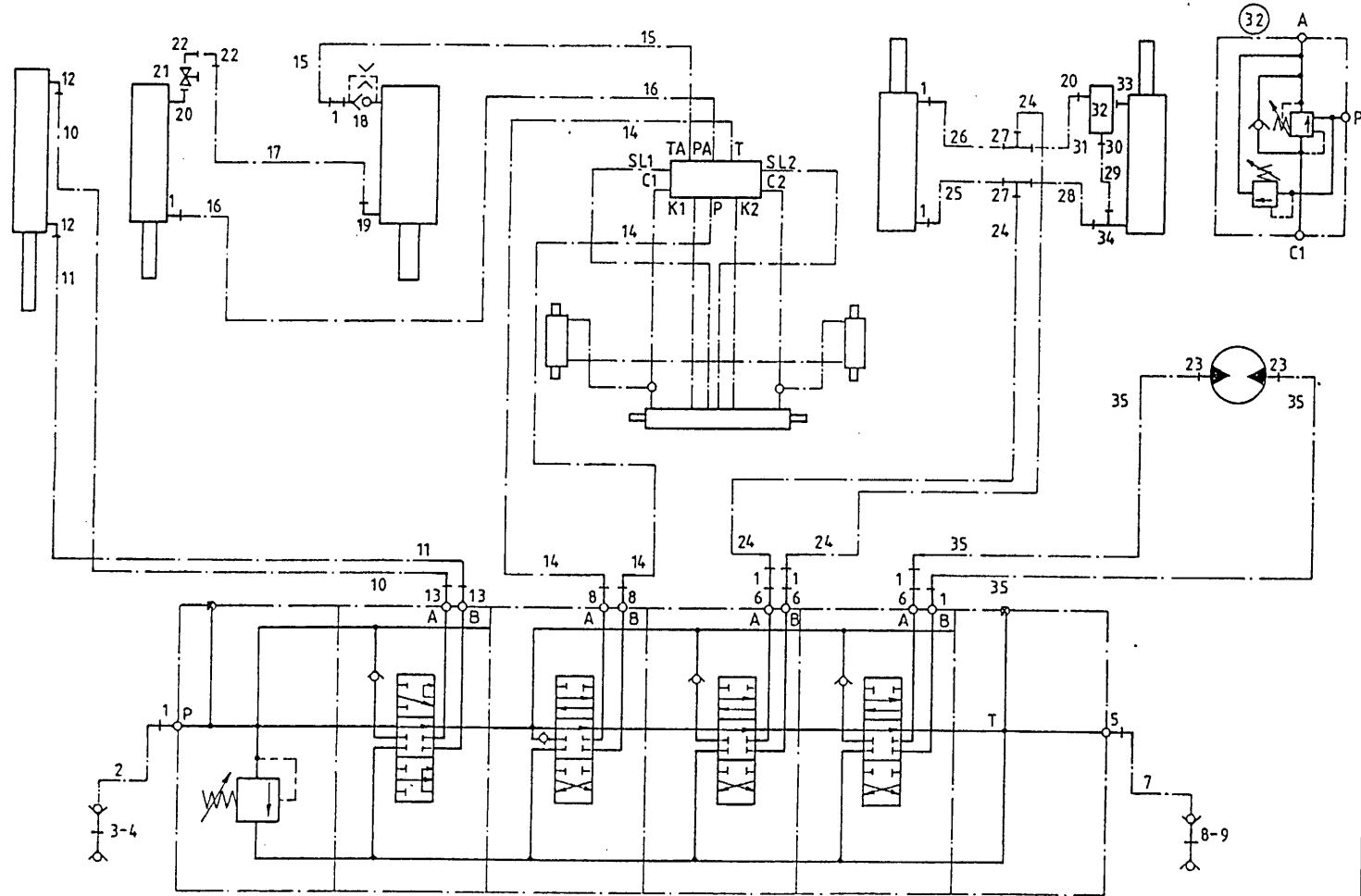

bestelnummer
ordernummer
Num. à commander
Bestellnummer

1	X50102	1	
2	W50768	1	½" 3000 RH
3	53303	1	
4	53301	1	
5	X50138	3	
6	50133	3	
7	W50738	1	⅝" 3000 RH
8	53315	1	
9	53326	1	
10	W50700	1	¼" 1800 RH
11	W50650	1	¼" 1000 RH
12	X50107	2	
13	X50114	2	
14A	W50965	2	8m³ ⅝" 7150 RH
14B	W50980	2	10m³ ⅝" 7400 RH
14C	W52601	2	12m³ ⅝" 7800 RH
14D	W52600	2	14m³ ⅝" 8650 RH
15A	W50846	1	8m³ ½" 3250 RH
15B	W50977	1	10m³/12m³ ½" 3350 RH
15C	W50921	1	14m³ ½" 3800 RH
16A	W50901	1	8m³ ½" 4770 RH
16B	W50975	1	10m³/ ½" 4870 RH
16C	W50789	1	12m³ ½" 5150 RR
16D	W52602	1	14m³ ½" 6000 RR
17A	W50789	1	8m³ ½" 5150 RR
17B	W50999	1	10m³ ½" 5400 RR
17C	W52612	1	12m³ ½" 5600 RR
17D	W52602	1	14m³ ½" 6000 RR
18	53192	1	
19	X50101	1	
20	50103	1	
21	51044	1	
22	X50143	2	
23	X50117	2	
24	W50825	2	½" 1600 RH
25	W50726	1	½" 2000 RH
26	W50725	1	½" 2600 RH
27	X50357	2	
28B	W50973	1	10m³/12m³ ½" 400 RH
28C	W50688	1	14m³ ½" 600 RH

92126/1

Afbeelding 22 : Slangenschema elektrische bediening

Abbildung 22 : Schaltplan Elektrische Fernbedienung

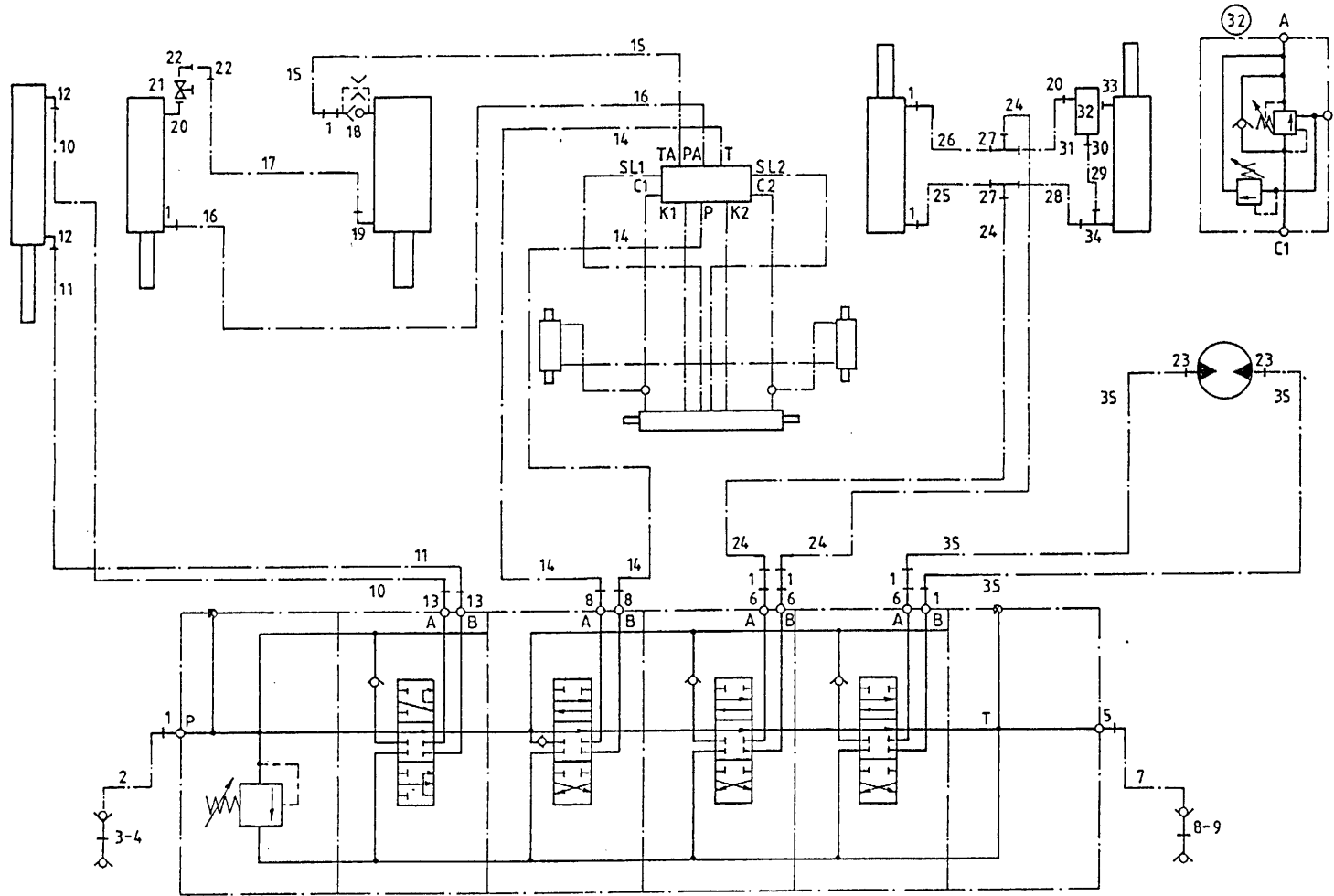

bestelnummer

ordernummer

Num. à commander

Bestellnummer

29	W50747	1	½" 650 RR
30	X50116	2	
31A	W50998	1	8m³/10m³/12m³ ½"1050 RH
31B	W50819	1	14m³ ½"1250 RH
32	53402	1	
33	50189	1	
34	50310	1	
35	W50602	2	½" 3500 RH

92126/1

Afbeelding 23 : Elektrische bedieningskast + schema
 Abbildung 23 : Elektrische Bedienungskasten + Schaltpläne

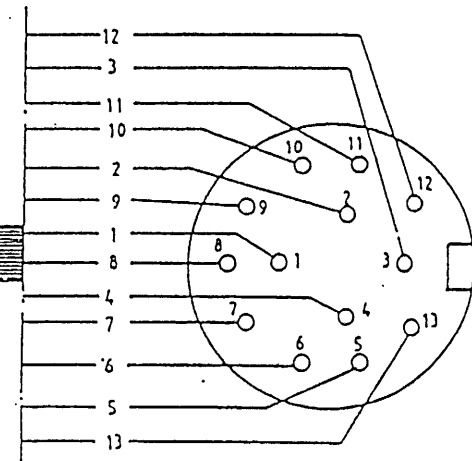
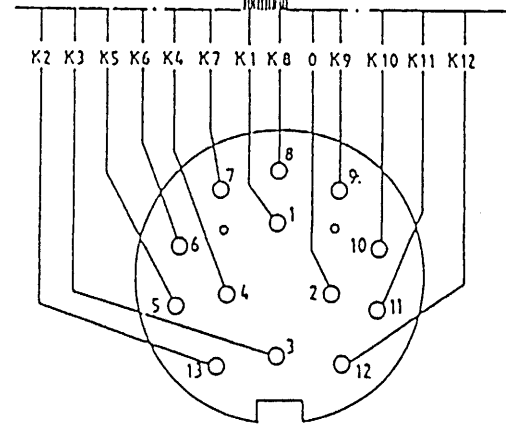
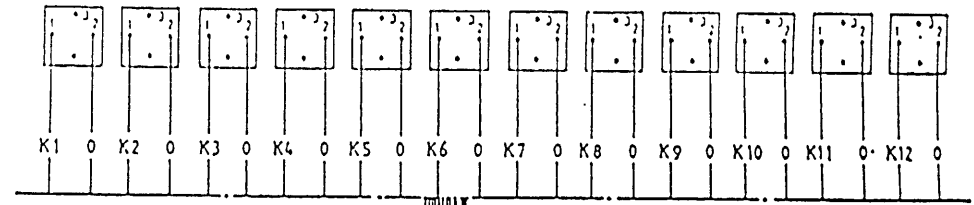
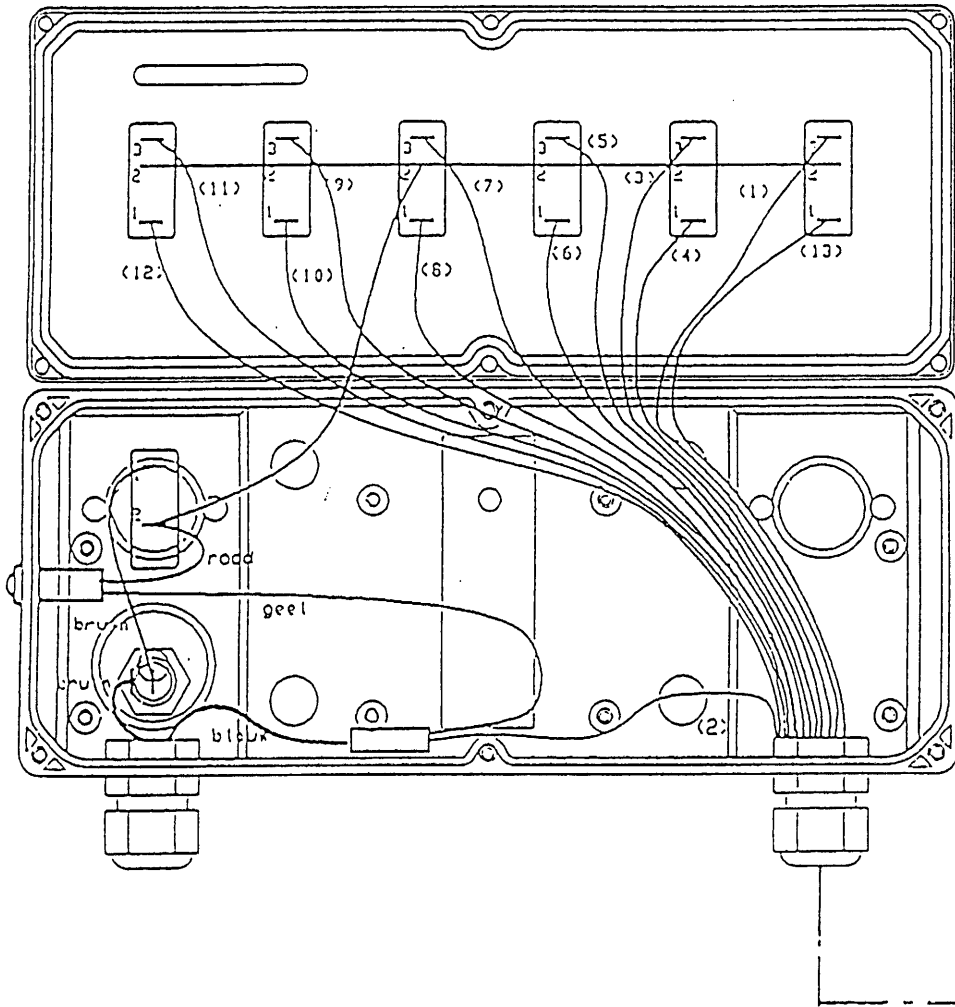

92126/1

Afbeelding 24 : Aftakas
 Abbildung 24 : Zapfwelle

bestelnummer
 ordernummer
 Num. à commander
 Bestellnummer

90495

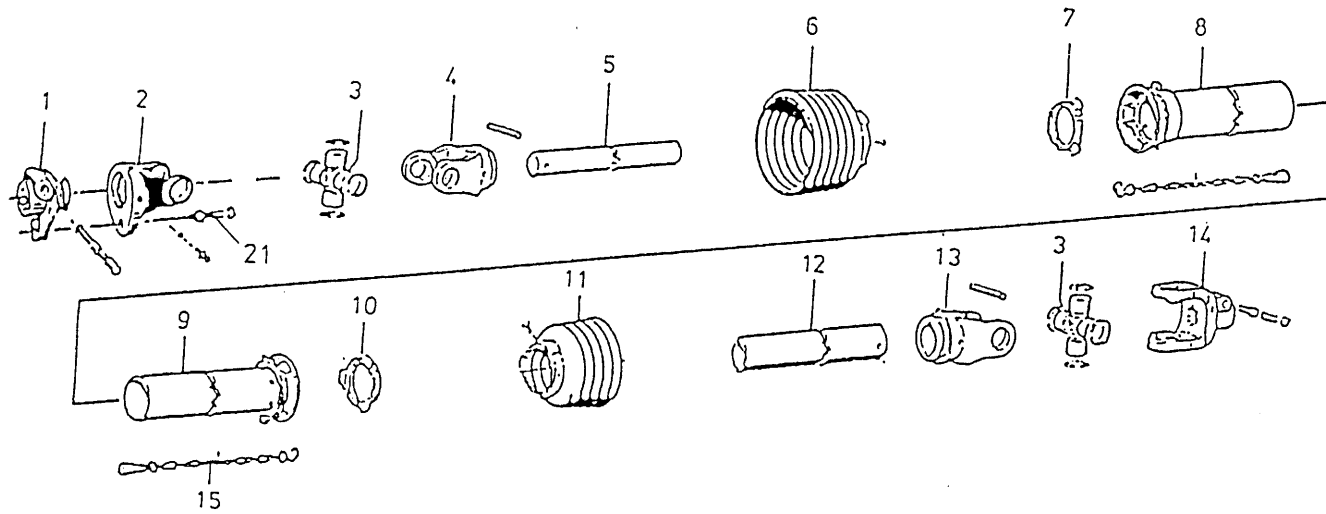

1	90613	1	M8 x 60
2	90614	1	
3	90615	2	
4	90616	1	
5	90617	1	
6	90618	1	
7	90619	1	
8	90620	1	
9	90621	1	
10	90622	1	
11	90623	1	
12	90624	1	
13	90625	1	
14	90626	1	
15	90266	2	
21	80860	1	

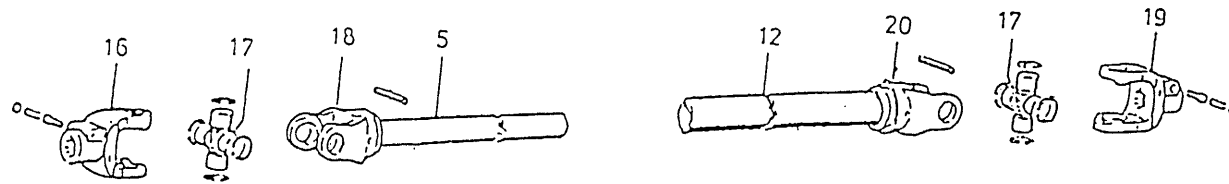

90559 / 90627 / 90560

16A	90575	1	Ø 48
16B	90563	1	1 3/8" - 6
16C	90562	1	1 3/4" - 20
17	90561	2	
18	90606	1	
19	90608	1	1 3/4" - 6
20	90607	1	



Trioliet Mullos B.V.

Himmanweg 19

7575 BE Oldenzaal - Holland

Postbus 134

7570 AC Oldenzaal - Holland

Tel.: 0541 - 57 21 21 / (+) 31 - 541 - 57 21 21

Fax 0541 - 57 21 25 / (+) 31 - 541 - 57 21 25

e-mail: info@trioliet.nl

<http://www.trioliet.nl>

Voor onderdelen / Für Ersatzteile:

Tel.: 0541 - 57 21 36 / (+) 31 - 541 - 57 21 36

Fax 0541 - 57 21 40 / (+) 31 - 541 - 57 21 40