

TRIOLIET

*Trioliet Mullos
Uitkildoseerwagen*

UKW 5000

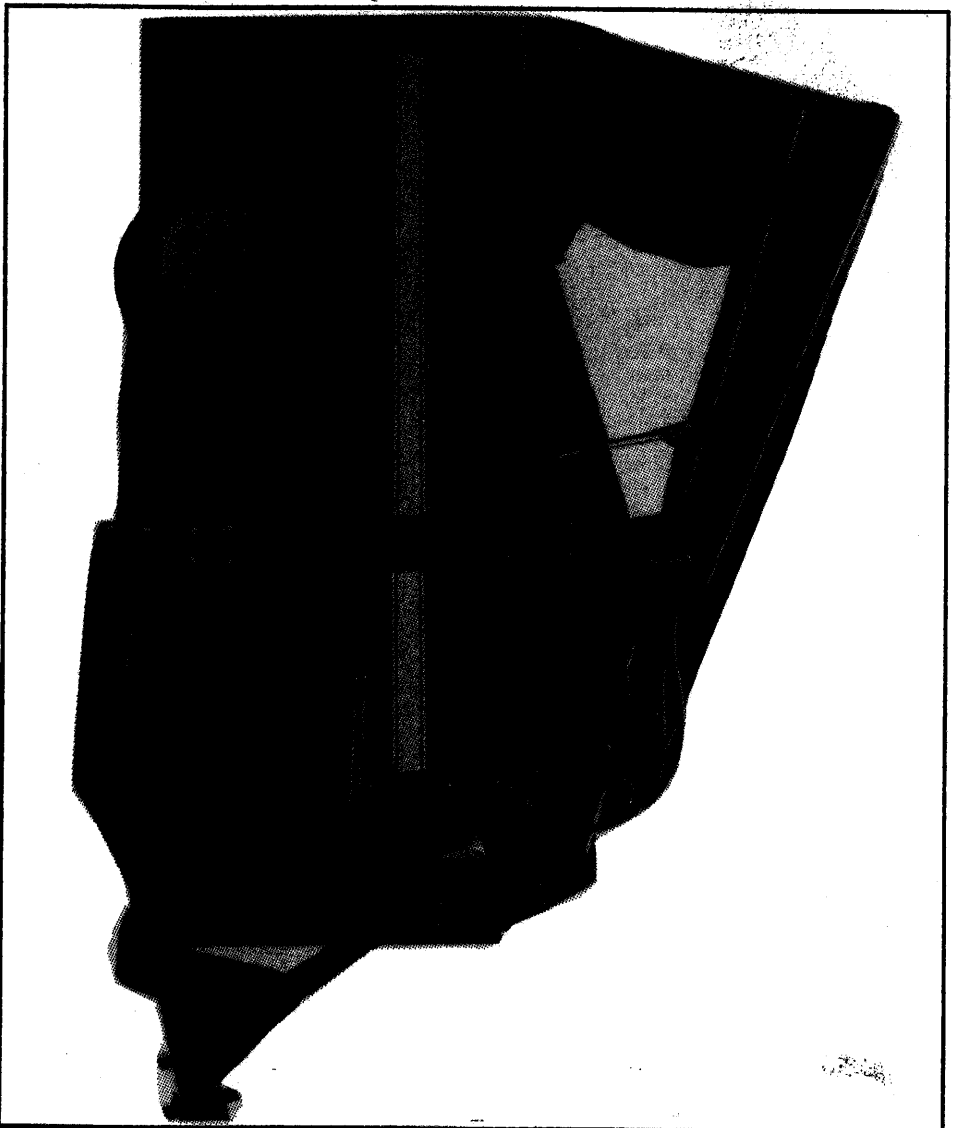

*Onderdelenlijst / Ersatzteilliste
Sparepartlist / Liste de pièces de réchange*

Bestelnummer / Bestellnummer 92026 / 1

Geldig vanaf productieserie nr. / Gültig ab Prod. Series No.: 01

INHOUDSOPGAVE

Sickers	1
Frame	2
Zijbeplating	3
Wielstel	4
Voortreplating	5
Dissel	6
Aanvoerband	7
Opvoerband	8
Dwarshand	9
Laadrichting	10
Snijsysteem	11
Krabbord	12
Slangen snijbord	13
Snuurventielblok	14
Hydraulische slangen	15/16
Mechanische bediening	17
Elektrische bediening	18
Omkastng bediening	19
Mesclinder	20
Disselcylinder	21
Aanzet- en intrekcilinder	22
Wielarmcilinder	23
Elektronisch weegsysteem	24
Pomp unit	25
Schakelschema mechanische bediening snijsysteem	26
Schakelschema elektrische bediening snijsysteem	27
Schakelschema mechanische bediening krabbord	28
Schakelschema elektrische bediening krabbord	29
Schakelschema snijsysteem	30

ATB

INHALT

Aufkleber	1
Grundrahmen	2
Seitenwände	3
Radachse	4
Vorwand	5
Deichsel	6
Bodenkette	7
Schnägförderkette	8
Seitentransportband	9
Laadsystem	10
Schneidplatte	11
Silokamm	12
Schläuche Schneidsystem	13
Ventillock	14
Hydraulik Schläuche	15/16
Mechanische Fernbedienung	17
Elektrische Fernbedienung	18
Schutzkappe Fernbedienung	19
Messerszylinder	20
Deichselzylinder	21
Schneidrahmenezylinder	22
Radarmzylinder	23
Elektronische Waage	24
Pumpenheit	25
Schalplan mechanische Fernbedienung Schneidsystem	26
Schalplan elektrische Fernbedienung Schneidsystem	27
Schalplan mechanische Fernbedienung Silokamm	28
Schalplan elektrische Fernbedienung Silokamm	29
Schalplan Schneidsystem	30

ABB

Afb. 1
Stickers
Aufkleber

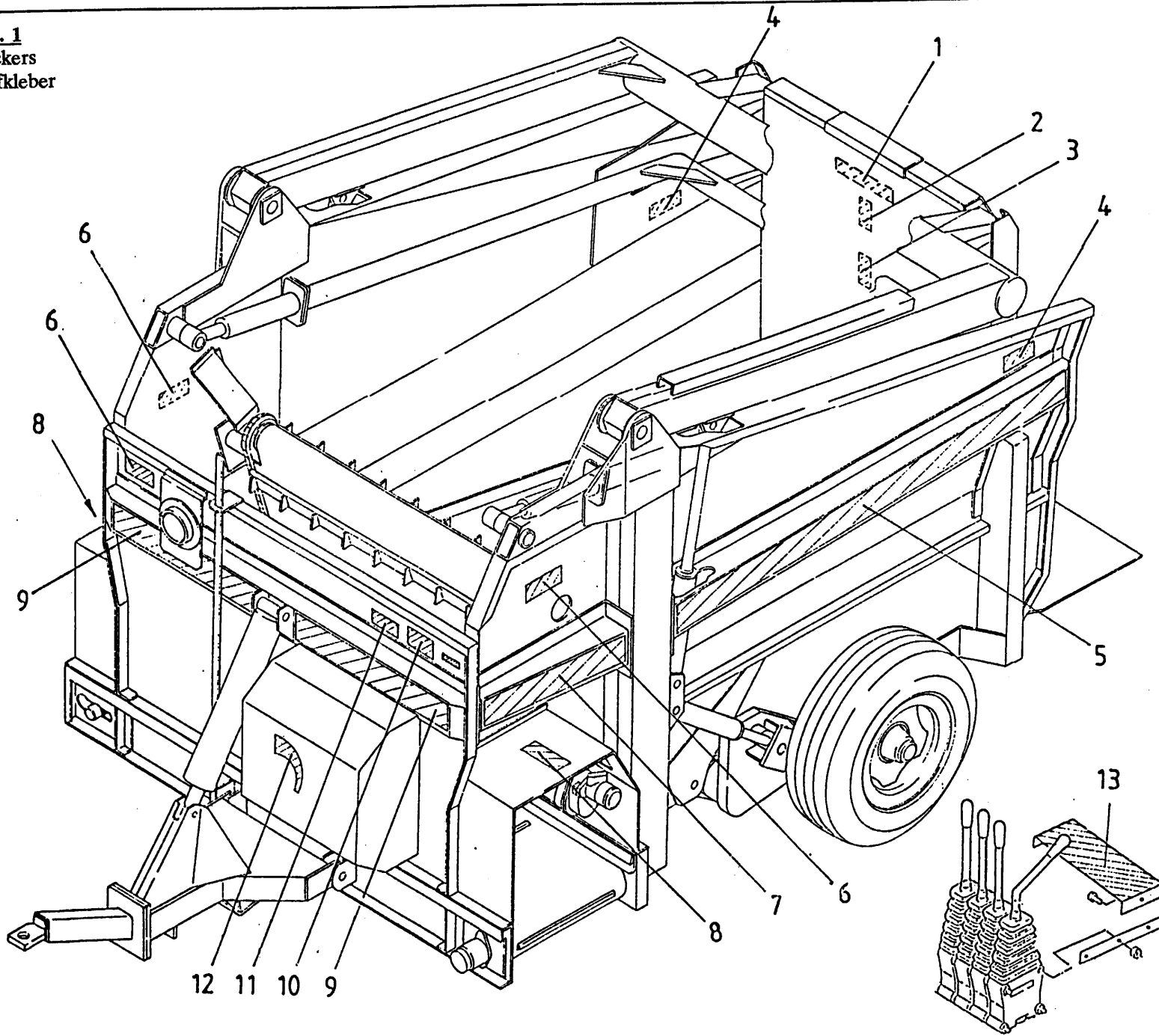

bestelnummer
ordernummer
num.à commander
Bestellnummer



1	91007	
2	91153	1
3	91163	1
4	91161	2
5	91169	2
6	91164	3
7	91167	2
8	91162	2
9	91166	2
10	91160	1
11	91159	1
12	91165	1
13	91168	1

Afb. 2
Frame
Grundrahmen

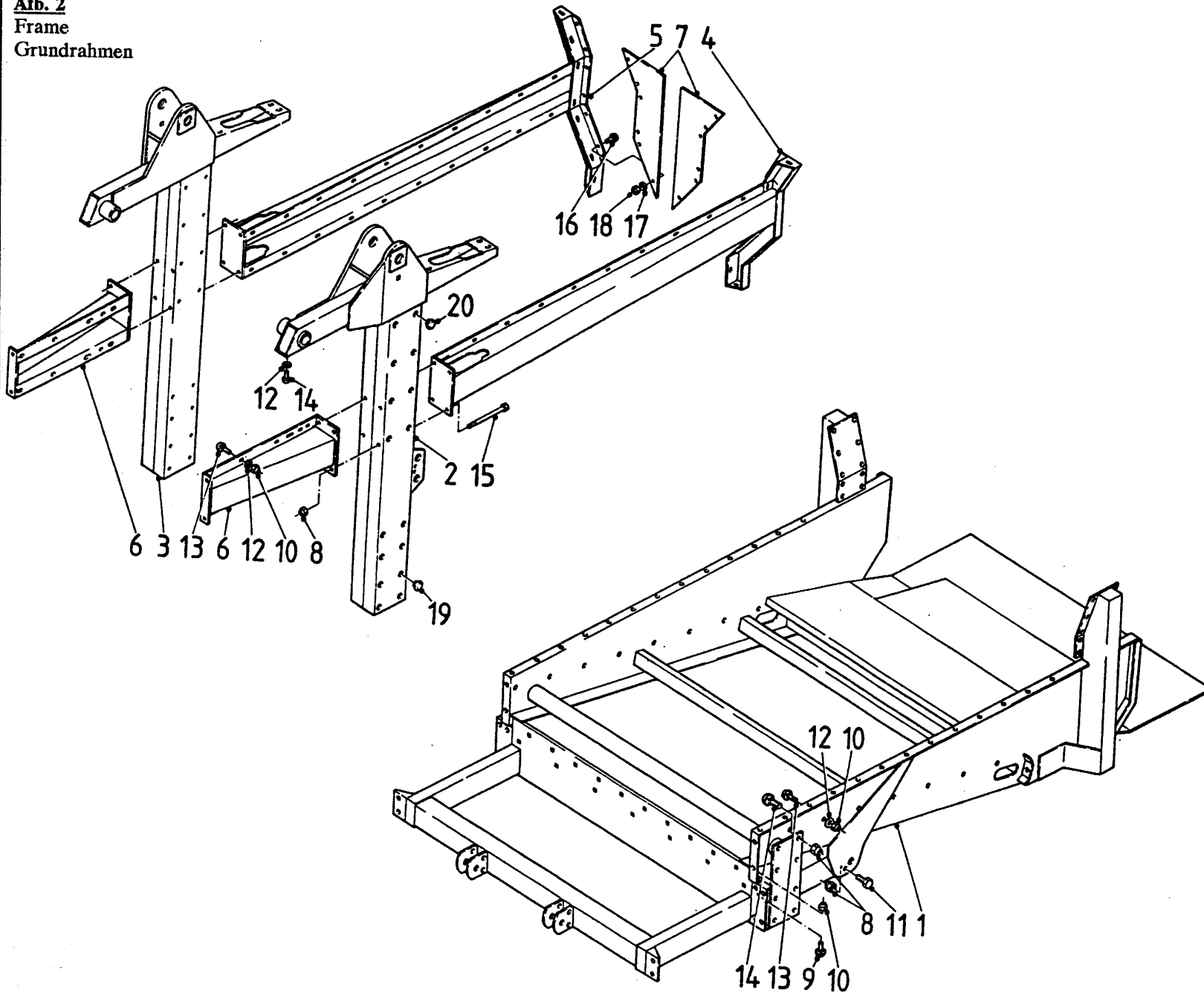

bestelnummer
ordernummer
num.à commander
Bestellnummer

1	10864	1	
2	10852	1	
3	10853	1	
4	10919	1	
5	10920	1	
6	10914	2	
7	30787	2	
8	86512	26	M12
9	83125	4	M10x25
10	86510	36	M10
11	81231	2	
12	85110	36	
13	83120	22	M10x20
14	84703	4	M10x20
15	81222	8	M12x210
16	83621	12	M6x22
17	85106	12	
18	86506	12	M6
19	60167	16	
20	60166	16	



Afb. 3
Zijbeplating
Seitenwände

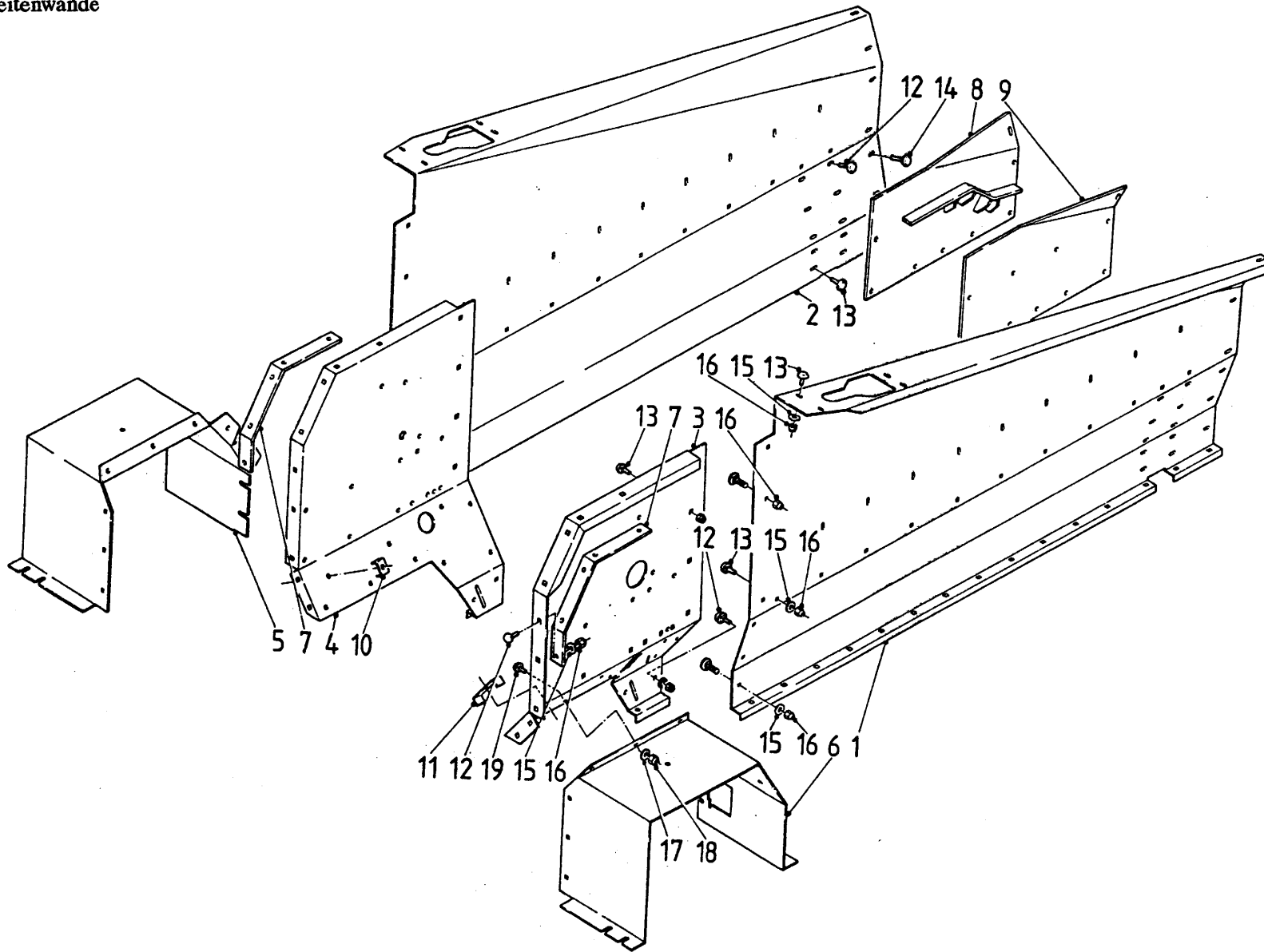

bestelnummer
ordernummer
num.à commander
Bestellnummer

1	22074	1
2	22073	1
3	22084	1
4	22085	1
5	40252	1
6	40251	1
7	UE385	2
8	10925	1
9	10924	1
10	22091	3
11	22089	2
12	83125	26 M10x25
13	83120	64 M10x20
14	83136	2 M10x35
15	85110	55
16	86510	104 M10
17	85108	6
18	86508	6 M8
19	83816	6 M8x16

Afb. 4
Wielstel
Radachse

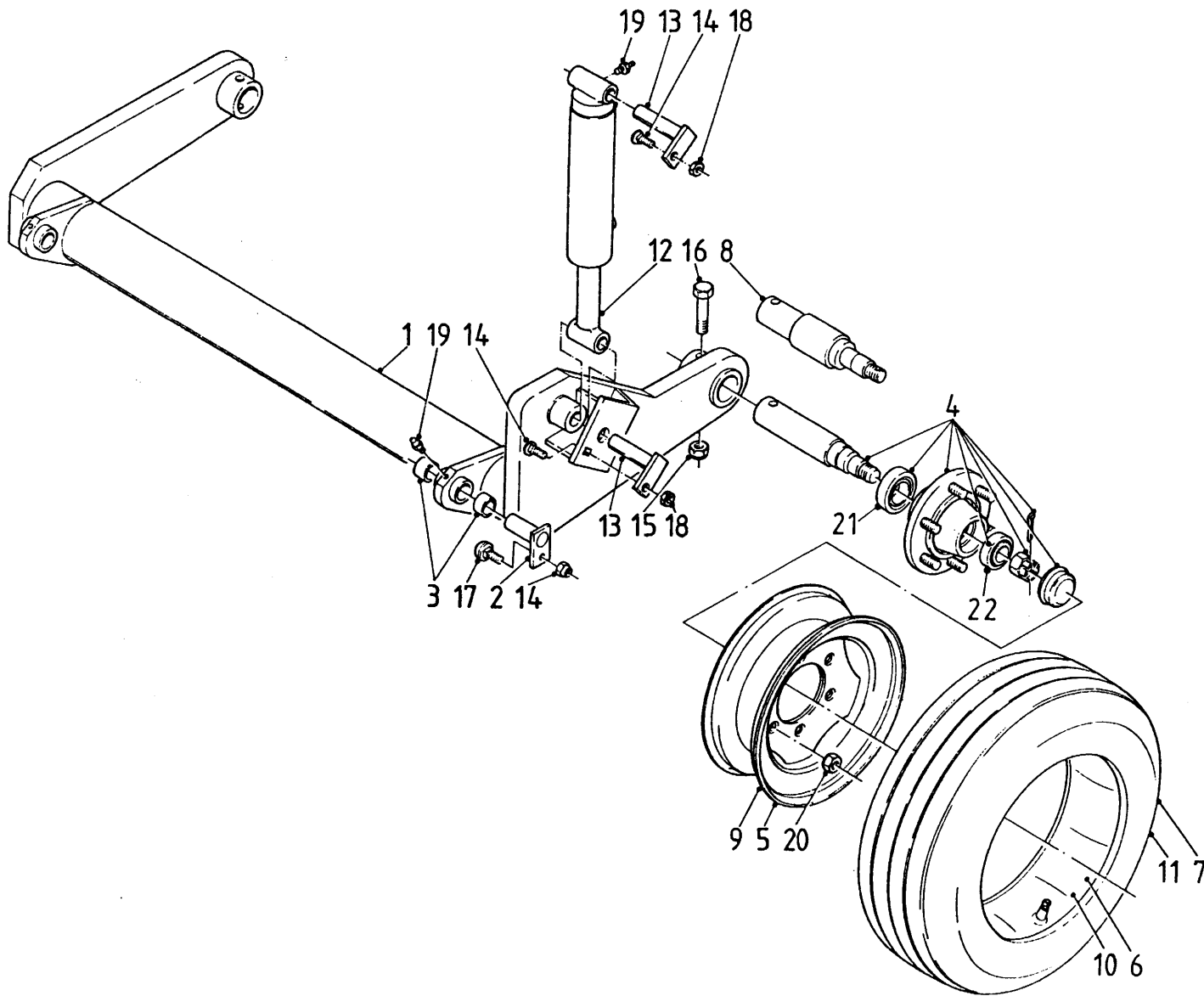

bestelnummer
 ordernummer
 num.à commander
 Bestellnummer

1	10904	1	
2	UE060	2	
3	UE452	4	
4	90150	2	
5	90153	2	
6	90152	2	
7	90151	2	
8	90169	2	
9	90156	2	
10	90155	2	
11	90154	2	
12	50076	1	
13	10917	1	
14	86512	3	M12
15	86516	2	M16
16	81610	2	M16X100
17	83231	2	M12X30
18	81235	1	M12X35
19	89503	4	M6
20	86119	12	M18X1,5
21	70057	2	30211
22	70056	2	30208

Afb. 5
Frontaanbouw
Vorwand

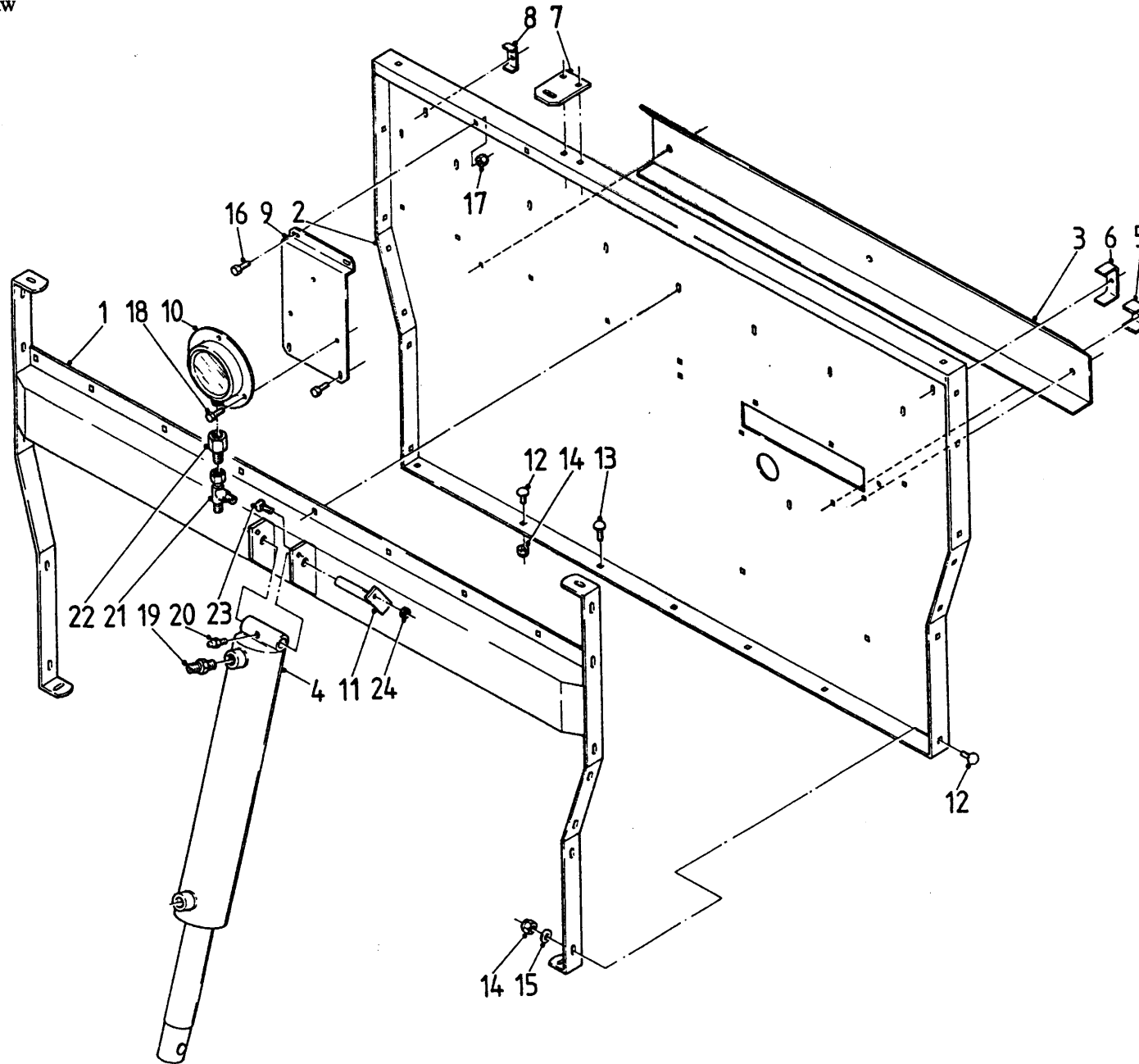

bestelnummer
 ordernummer
 num.à commander
 Bestelnummer



1	10922	1	
2	22078	1	
3	40254	1	
4	UE00200	1	
5	22226	1	
6	22090	1	
7	UE343	1	
8	22091	1	
9	UE414	1	
10	UE404	1	
11	UE0236	1	
12	83125	20	M10x25
13	83120	3	M10x20
14	86510	23	M10
15	85110	18	
16	80821	4	M8x20
17	86508	4	M8
18	84703	4	M10x20
19	50104	2	
20	89503	1	
21	50415	1	
22	50300	1	

Afb. 6
Dissel
Deichsel

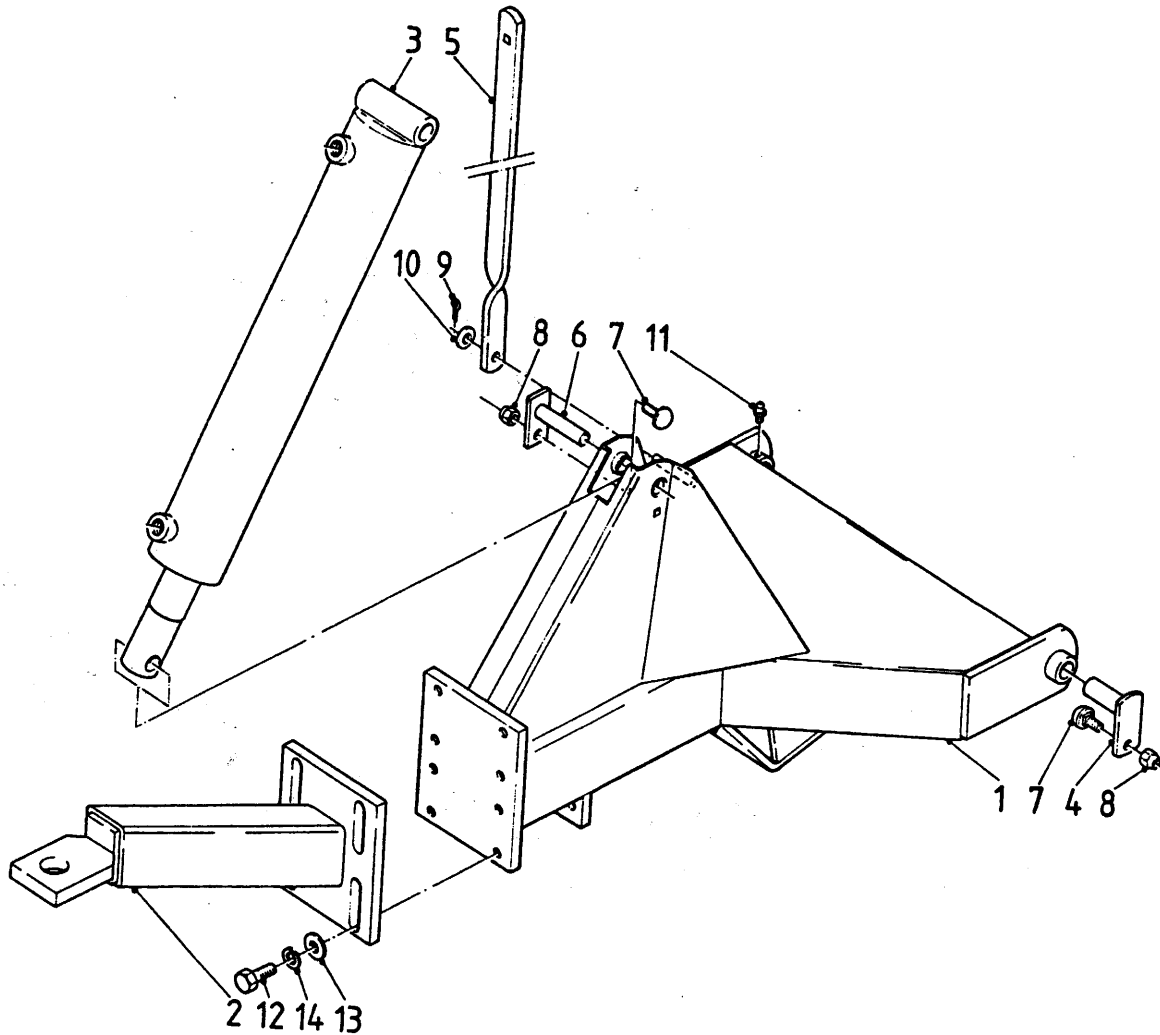

bestelnummer
ordernummer
num.à commander
Bestellnummer



1	10935	1
2	10980	1
3	22224	1
4	UE0287	2
5	00200	1
6	UE0236	1
7	83125	3 M10x25
8	86510	3 M10
9	85112	1
10	88225	1
11	89503	2
12	83650	4 M16x50
13	85116	4
14	86516	4 M16

Afb. 7
Aanvoerband
Bodenkette

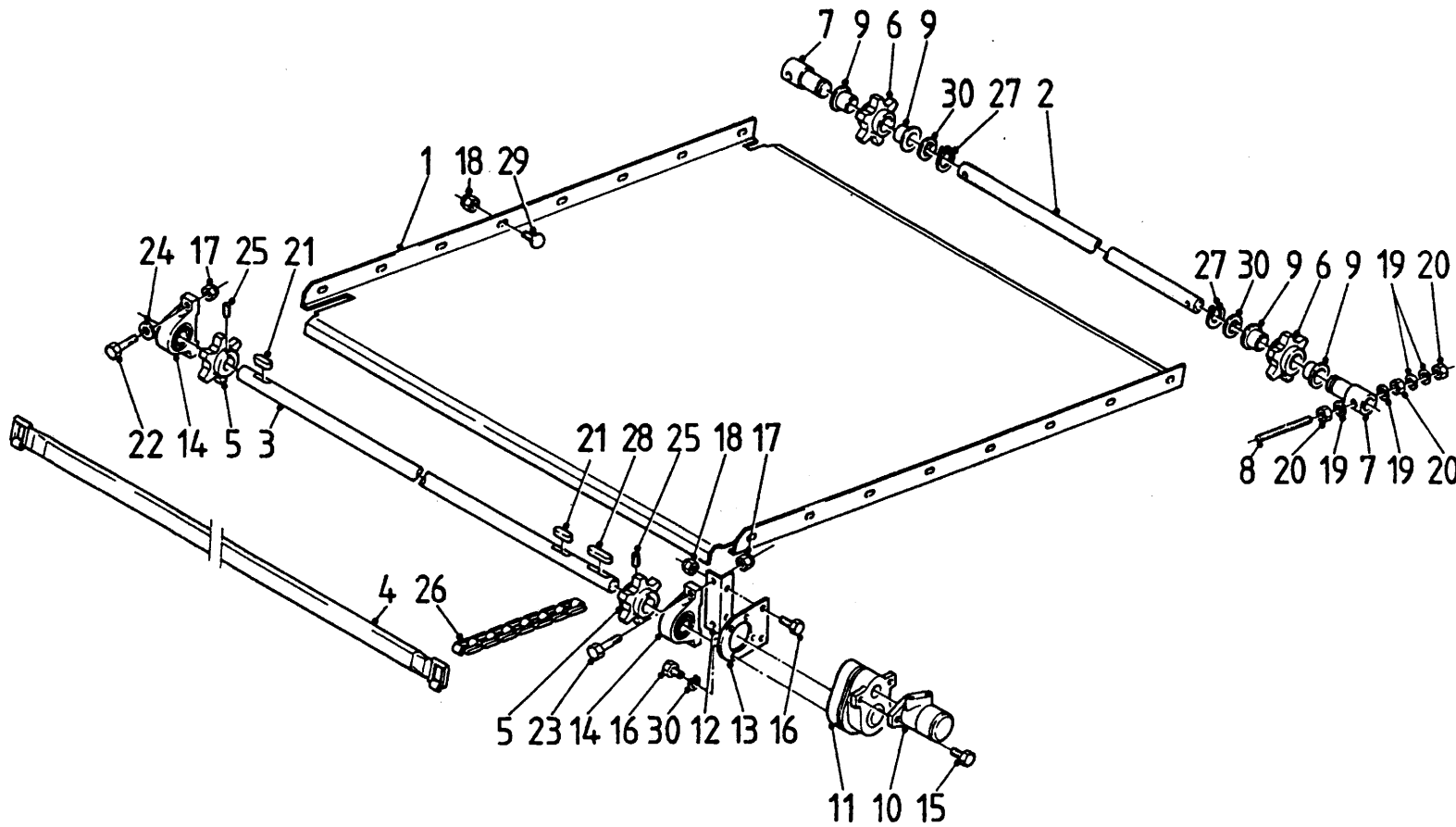

bestelnummer
 ordernummer
 num.à commander
 Bestellnummer



1	22072	1	
2	30782	1	
3	30783	1	
4	10913	8	
5	UE235	2	
6	30785	2	
7	30784	2	
8	UE317	2	
9	51766	4	
10	50067	1	
11	50085	1	
12	UE291	1	
13	UE292	1	
14	70035	2	
15	81231	2	M12x30
16	81020	8	M10x20
17	86512	4	M12
18	86510	20	M10
19	85116	8	
20	86116	6	M16
21	88360	2	
22	81246	2	M12x45
23	81255	2	M12x55
24	85112	4	
25	84140	2	M10x16
26	39010	112	
27	87040	2	
28	88375	1	
29	83120	16	M10x20
30	85341	2	

Afb. 8
Opvoerband
Schrägförderkette

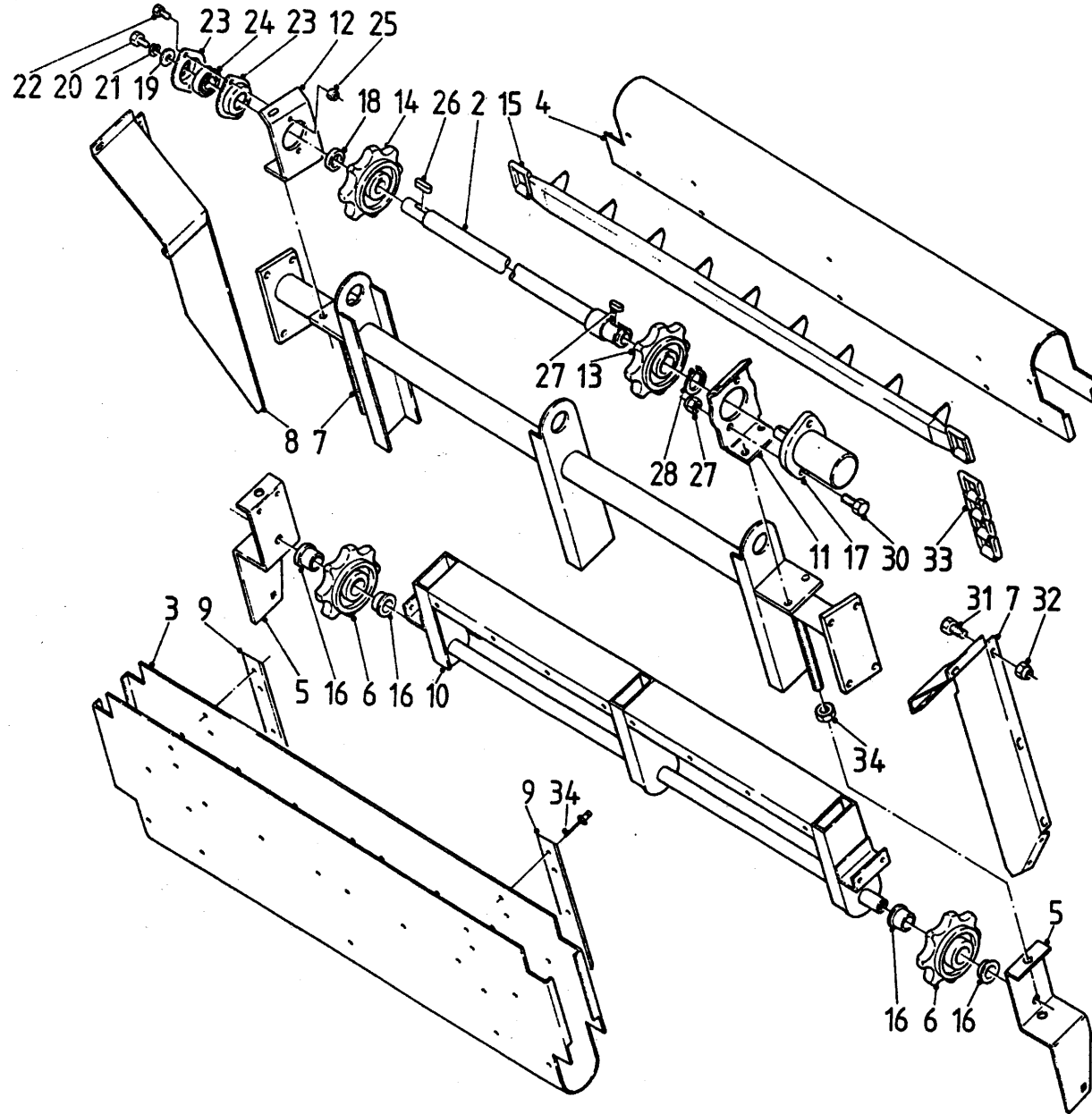

bestelnummer
ordernummer
num.à commander
Bestellnummer

1	10918	1	
2	10941	1	
3	40256	1	
4	40257	1	
5	22098	2	
6	30794	2	
7	40250	1	
8	40249	1	
9	UE316	2	
10	UE0383	1	
11	UE175	1	
12	UE176	1	
13	UE264	1	
14	UE265	1	
15	UE0294	5	
16	51767	4	
17	50078	1	
18	UE277	3	
19	HK116	1	
20	81020	1	M10x20
21	85010	1	
22	81025	2	M10x25
23	70050	1	
24	70054	1	
25	86510	2	M10
26	88340	1	
27	88335	1	
28	87042	1	
29	86512	2	
30	81235	2	M12x35
31	80816	12	M8x16
32	86508	12	M8
33	39010	40	
34	86116	2	M16



Afb. 9
Dwarsband
Seitentransportband

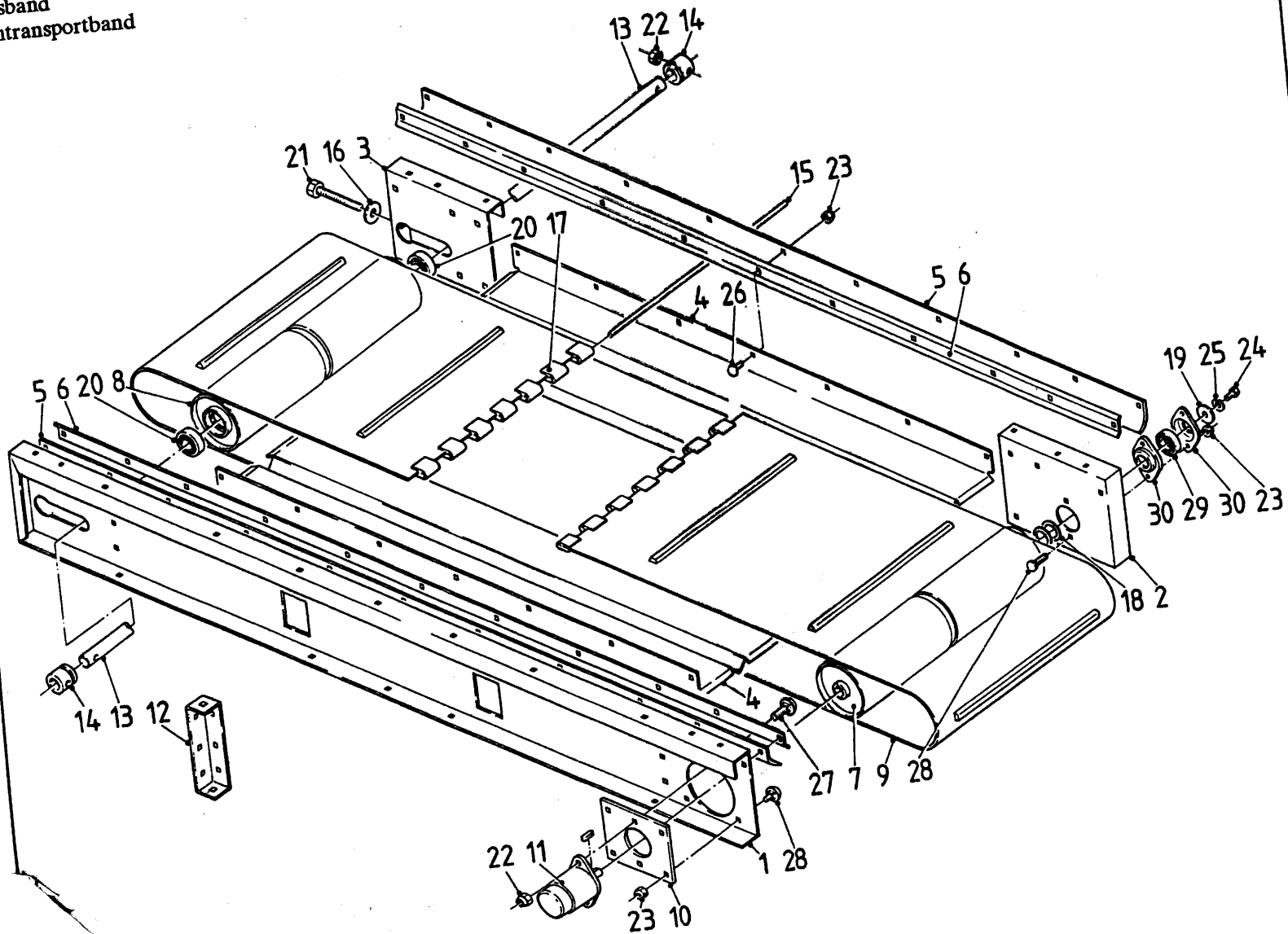

bestelnummer
 ordernummer
 num.à commander
 Bestellnummer

1	22083	1	
2	22082	1	
3	22081	1	
4	ue371	2	
5	30793	2	
6	40248	2	
7	10938	1	
8	UE359	1	
9	UE360	1	
10	UE397	1	
11	50077	1	
12	UE013	2	
13	UE369	1	
14	UE399	2	
15	UE178	1	
16	TA195		
17	UE403	2	M
18	DS59V	2	M
19	HK116	1	M
20	70051	2	M
21	81218	2	M
22	86512	4	M
23	86510	22	M
24	83020	1	M
25	85010	1	M
26	83120	16	M
27	83241	2	M
28	83125	6	M
29	70050	1	M
30	70054	1	M

Afb. 10
 Laadinrichting
 Laadsysteem

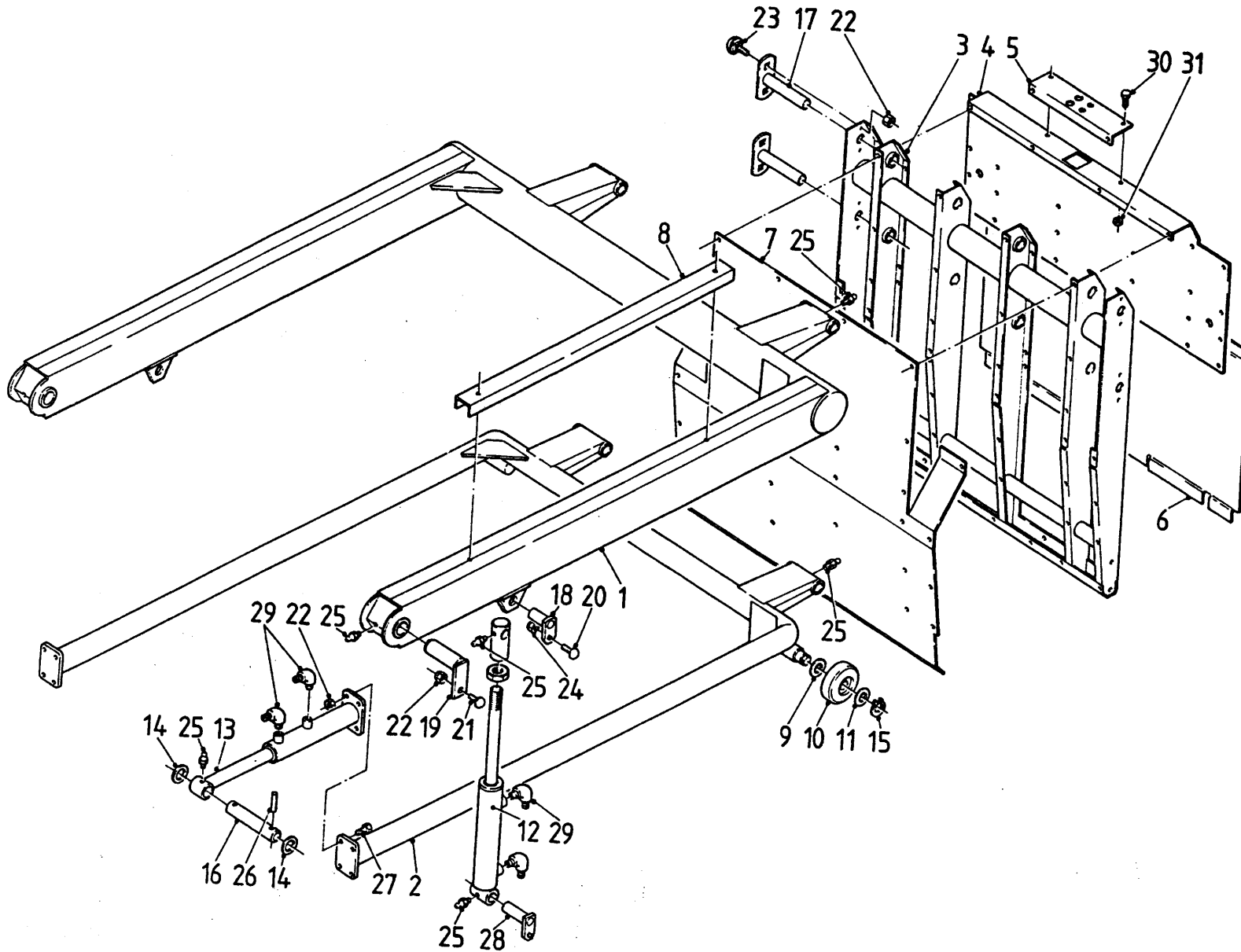

bestelnummer
 ordernummer
 num.à commander
 Bestellnummer

1	10911	1	
2	10912	1	
3	10916	1	
4	22104	1	
5	22103	1	
6	22102	1	
7	40255	1	
8	40253	1	
9	85340	2	
10	60017	2	
11	85341	2	
12	UE00217	2	
13	UE00523	1	
14	HS48V	2	
15	87041	2	
16	UE218	2	
17	UE0164	4	
18	UE080	2	
19	10910	2	
20	83125	2	M10x25
21	83231	2	M12x30
22	86512	18	M12
23	83236	8	M12x35
24	86510	2	M10
25	89503	12	
26	88170	4	
27	81241	8	M12x40
28	10915	2	
29	50103	4	



Afb. 11
Snijraam
Schneidplatte

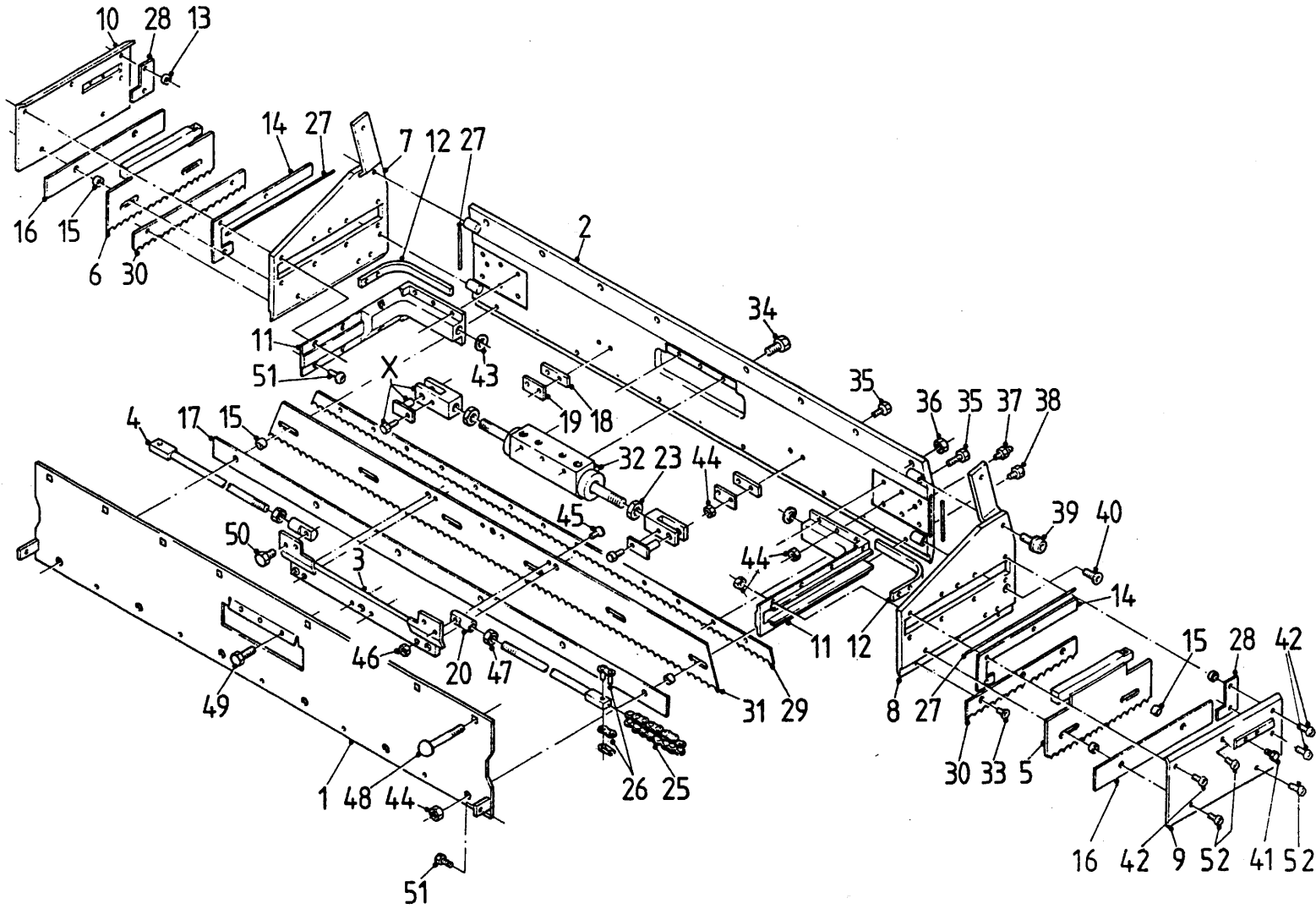

bestelnummer
 ordernummer
 num.à commander
 Bestellnummer



1	10986	1
2	10987	1
3	10994	1
4	10966	2
5	10991	1
6	10992	1
7	10988	1
8	10989	1
9	22263	1
10	22280	1
11	30851	2
12	22289	2
13	30879	4
14	22283	2
15	30871	10
16	60160	2
17	60161	1
18	22249	2
19	22284	2
20	30849	2
X	05024	2
22	30225	2
23	86115	2
24	85218	19
25	39070	2
26	39071	4
27	60163	1
28	60162	2
29	21915	1
30	22233	2
31	22231	1
32	50083	1
33	85218	19
34	83920	3 M10x30
35	84810	16 M8x30
36	86512	8 M12
37	89503	2
38	84143	6 M8x25
39	83921	2 M10x25
40	84102	2 M10x30
41	83610	4 M6x10
42	84810	3 M8x30
43	52026	2
44	86508	24 M8
45	84142	6 M6x20
46	86506	4 M6
47	86915	2 M12
48	83280	8 M12x80
49	84802	3 M10x30
50	83920	2 M10x20
51	84809	16 M8x12
52	84806	6 M8x16

Afb. 12
Krabarm
Silokamm

bestelnummer
ordernummer
num.à commander
Bestellnummer



Afb. 13
Slangen snijbord
Schläuche Schneidsystem

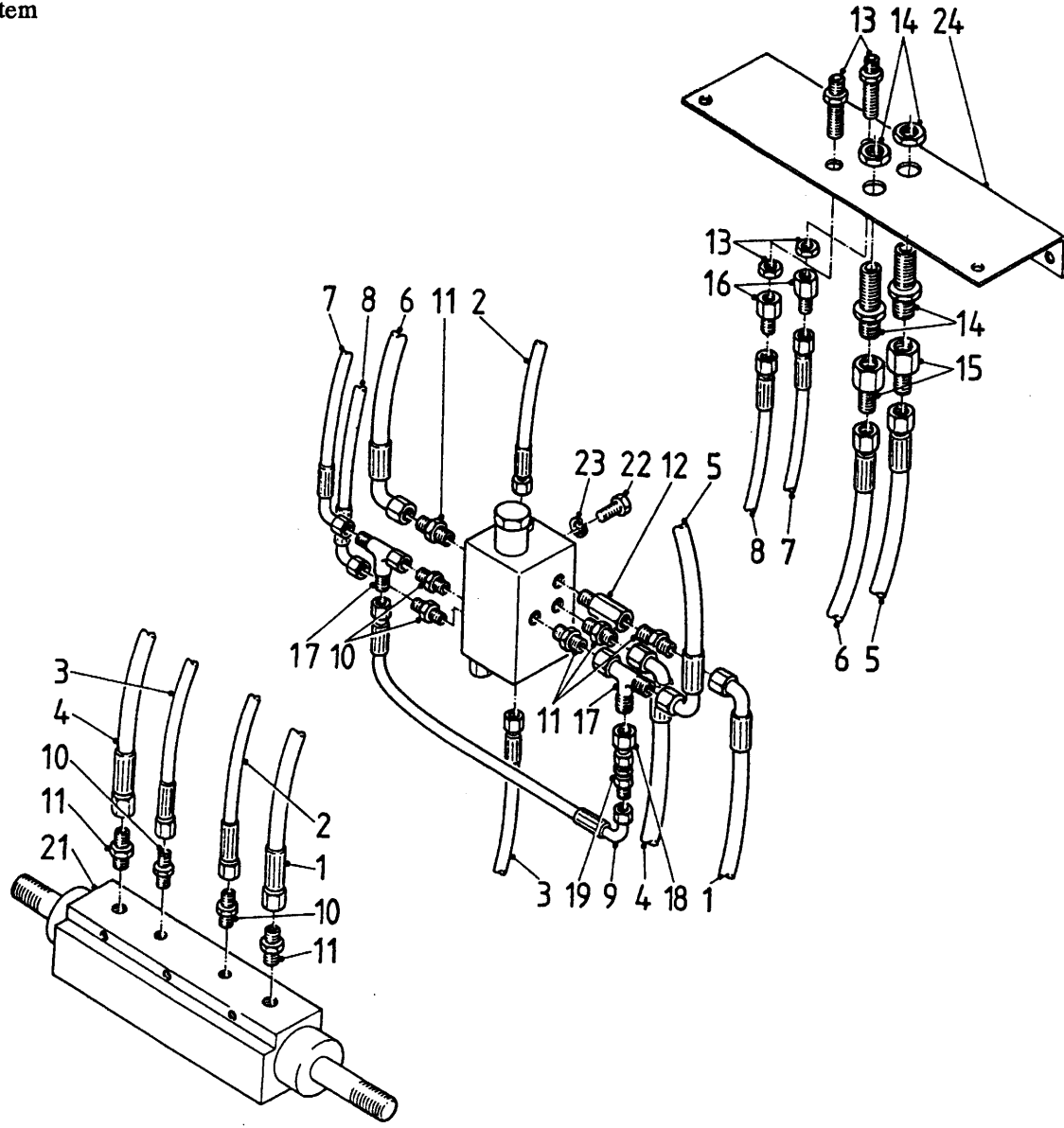

bestelnummer
ordernummer
num.à commander
Bestellnummer

1	50668	1
2	50607	1
3	50742	1
4	50688	1
5	50692	1
6	50692	1
7	50719	1
8	50719	1
9	50630	1
10	50104	5
11	50102	4
12	50133	1
13	50502	2
14	50501	2
15	50161	2
16	50157	2
17	50303	2
18	50304	1
19	53018	1
20	53055	1
21	50083	1
22	80816	2
23	85008	2
24	22103	1



Afb. 14
Stuurventielblok
Ventilblock

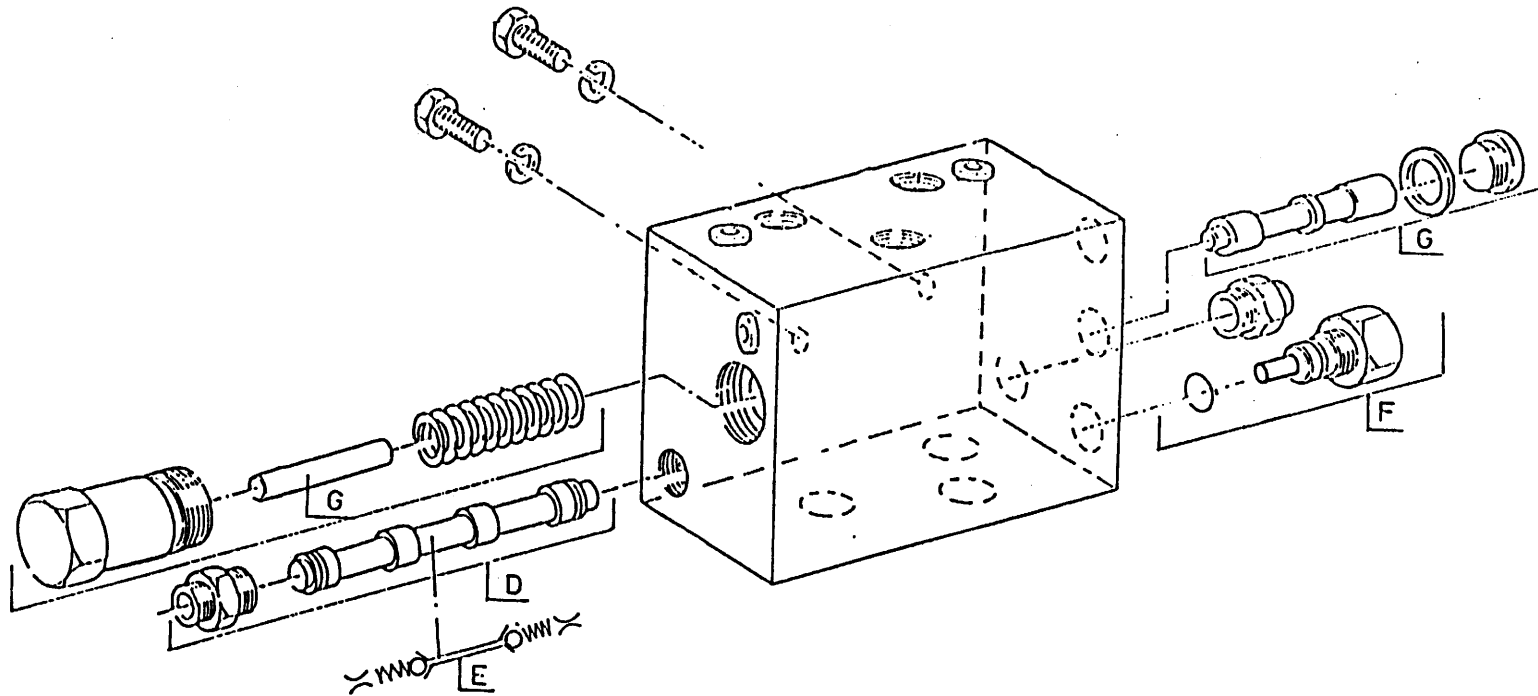

bestelnummer
ordernummer
num.à commander
Bestellnummer

F 05145 1



Afb. 15
 Hydraulische slangen
 Hydraulik Schläuche

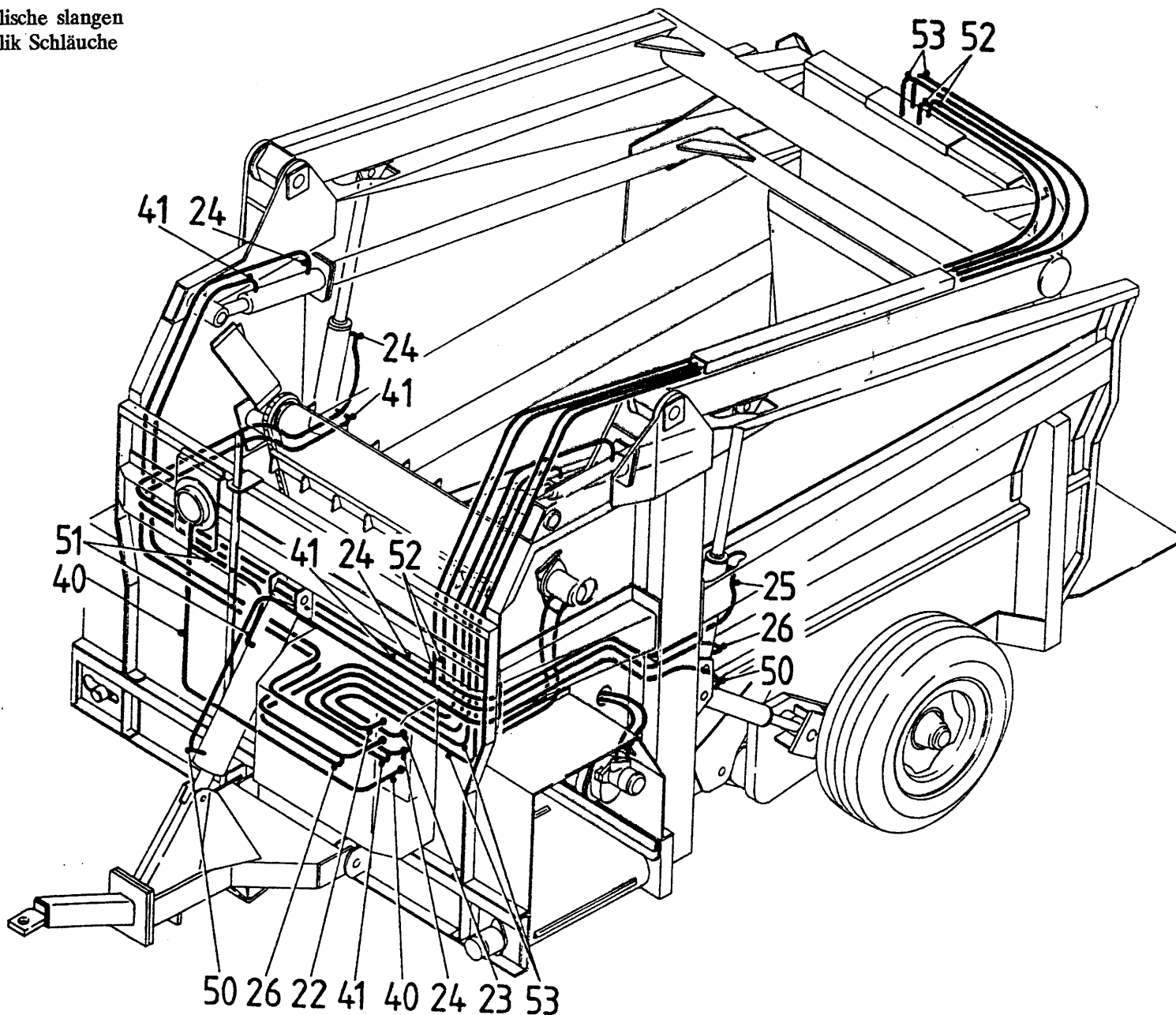

bestelnummer
 ordernummer
 num.à commander
 Bestellnummer

22	50734	1
23	50735	1
24	50713	2
25	50716	1
26	50715	1
40	50637	1
41	50714	2
50	50685	1
51	50621	1
52	50518	2
53	50517	2



Afb. 16
 Hydraulische slangen
 Hydraulik Schläuche

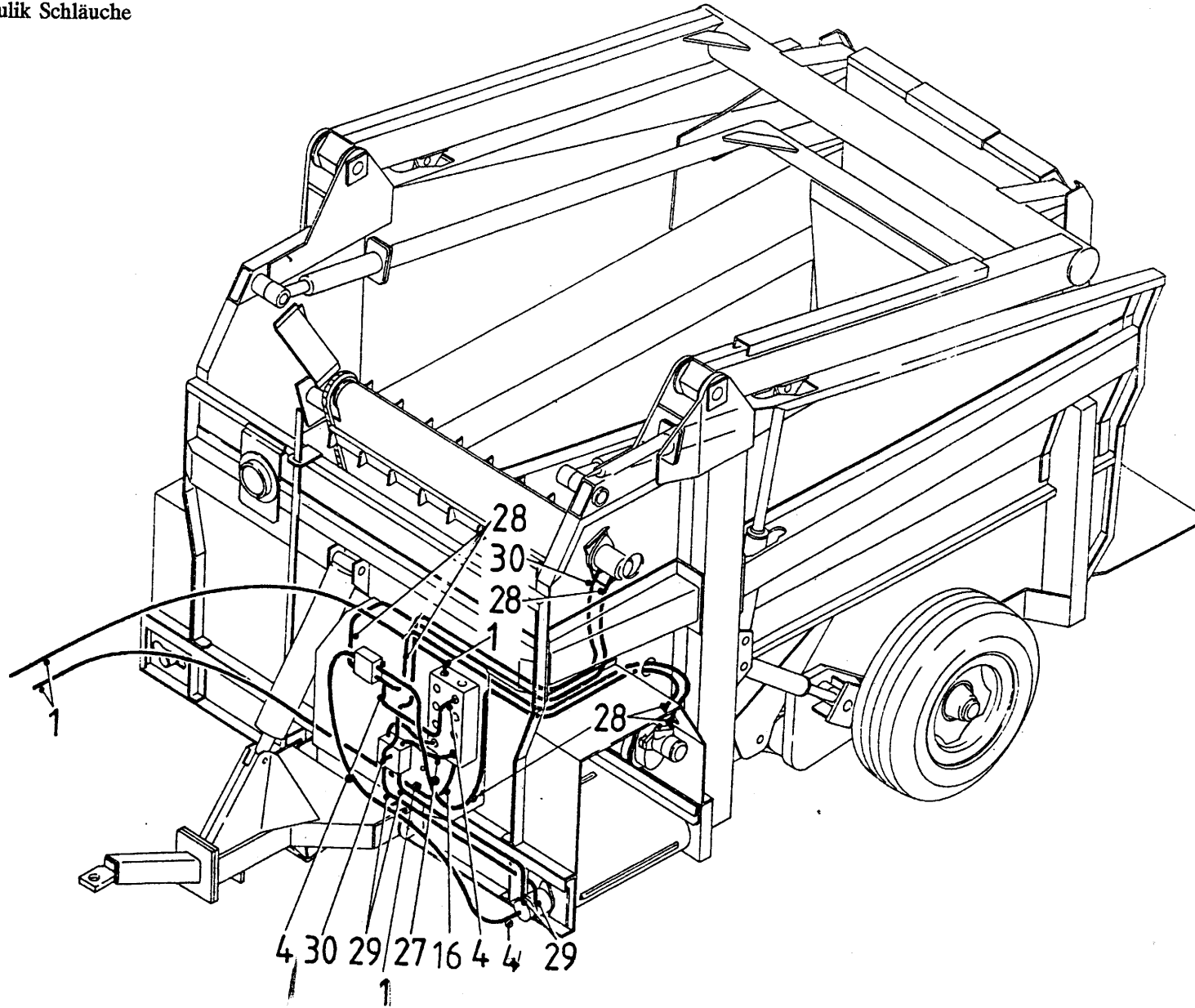

bestelnummer
 ordernummer
 num.à commander
 Bestellnummer

1	50738	2
4	50699	2
16	50735	1
27	50688	1
28	50601	3
29	50605	2
30	50604	1



Afb. 17
Mechanische bedienung
Mechanische Fernbedienung

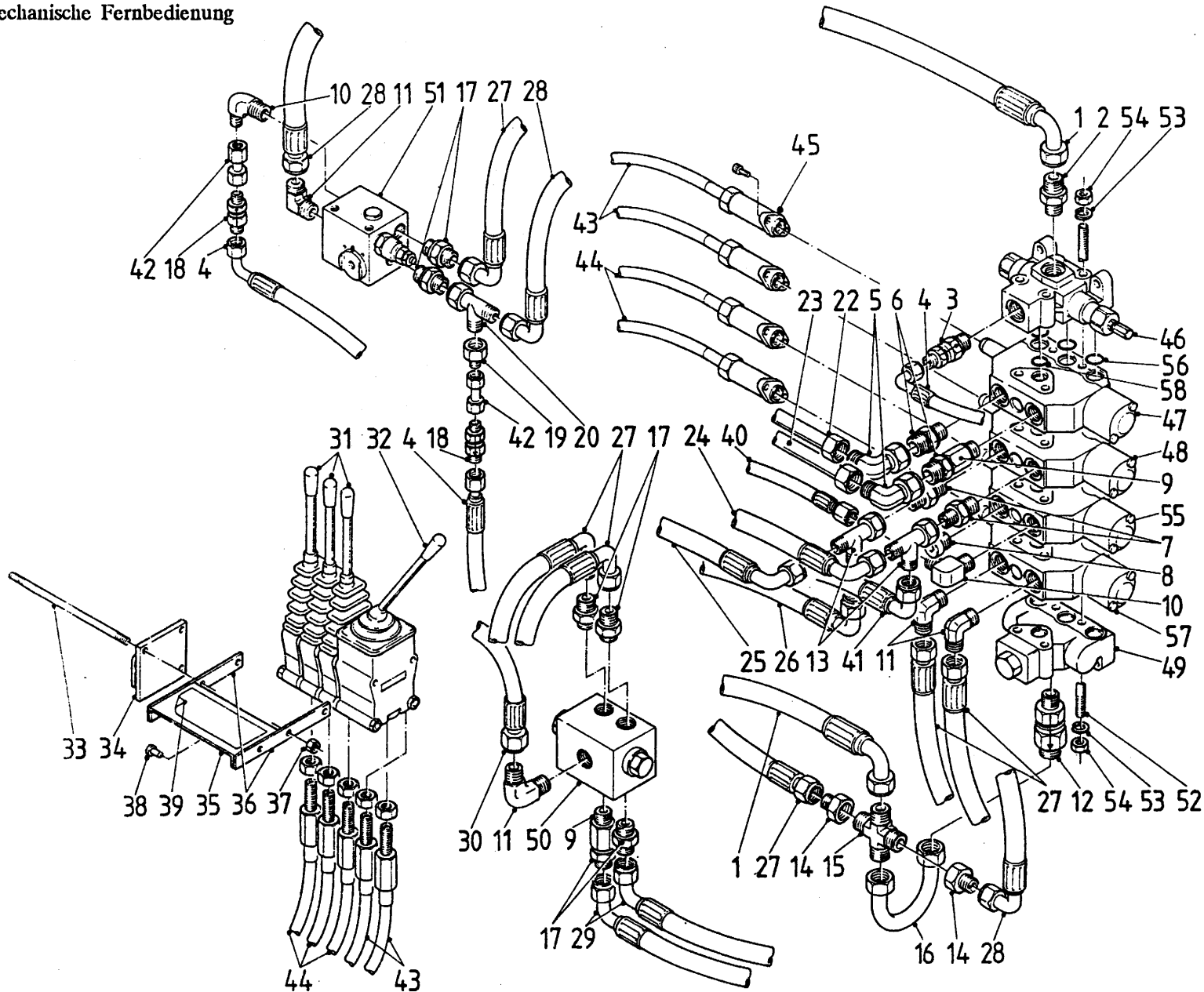

bestelnummer
ordernummer
num.à commander
Bestellnummer

1	50738	2	40	50637	1
2	50139	1	41	50714	1
3	50137	1	42	50739	2
4	50699	2	43	79053	2
5	50418	2	44	79054	3
6	50138	2	45	05114	4
7	50141	2	46	53070	1
8	53304	1	47	53071	1
9	50133	1-1	48	53072	1
10	50118	1	49	53075	1
11	50101	2-1-1	50	53064	1
12	53065	1	51	53063	1
13	50309	2	52	84026	4
14	50161	1-1	53	85008	4
15	50451	1	54	86108	4
16	50735	1	55	53073	1
17	50102	2-2-2	56	78055	3
18	53017	1-1	57	53074	1
19	50304	1	58	78056	1
20	50303	1			
21	50114	1			
22	50734	1			
23	50735	1			
24	50713	1			
25	50716	1			
26	50715	1			
27	50688	1			
28	50601	3			
29	50605	2			
30	50604	1			
31	53039	3			
32	05122	1			
33	30847	3			
34	10283	1			
35	22245	1			
36	22244	1			
37	86208	8			
38	80816	2			
39	91168	1			

Afb. 18

Elektrische bediening

Elektrische Fernbediening

bestelnummer
ordernummer
num.à commander
Bestellnummer



Afb. 20
Mescylinder
Messerzylinder

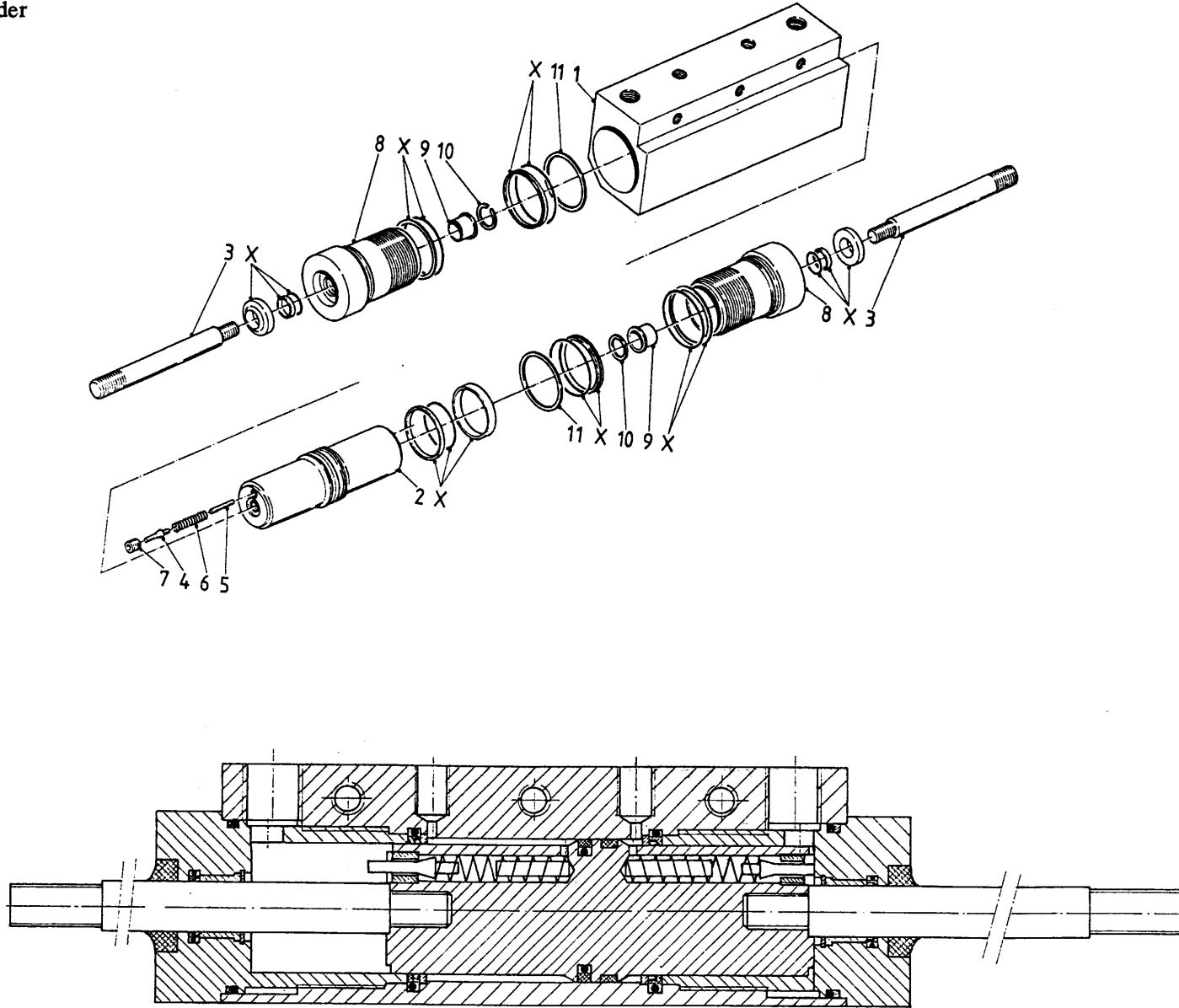

bestelnummer
ordernummer
num.à commander
Bestellnummer

1	30869	1
2	30866	1
3	30867	2
4	30865	2
5	88344	2
6	65051	2
7	30870	2
8	30863	2
9	30864	2
10	83711	2
11	30868	2
X	05140	1



Afb. 21
 Disselcylinder
 Deichselzylinder

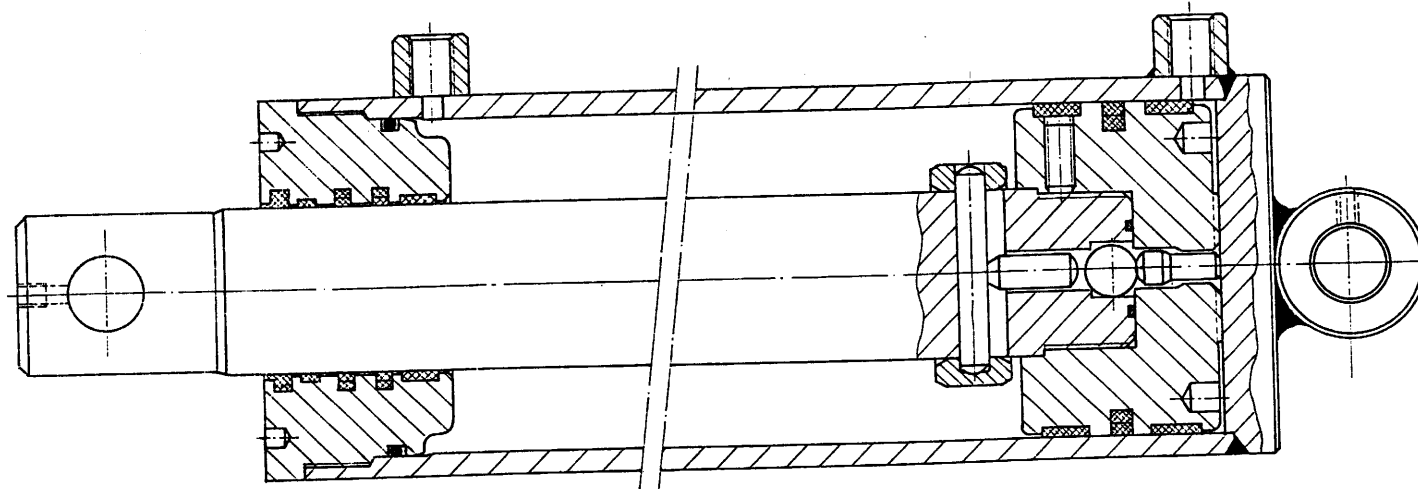
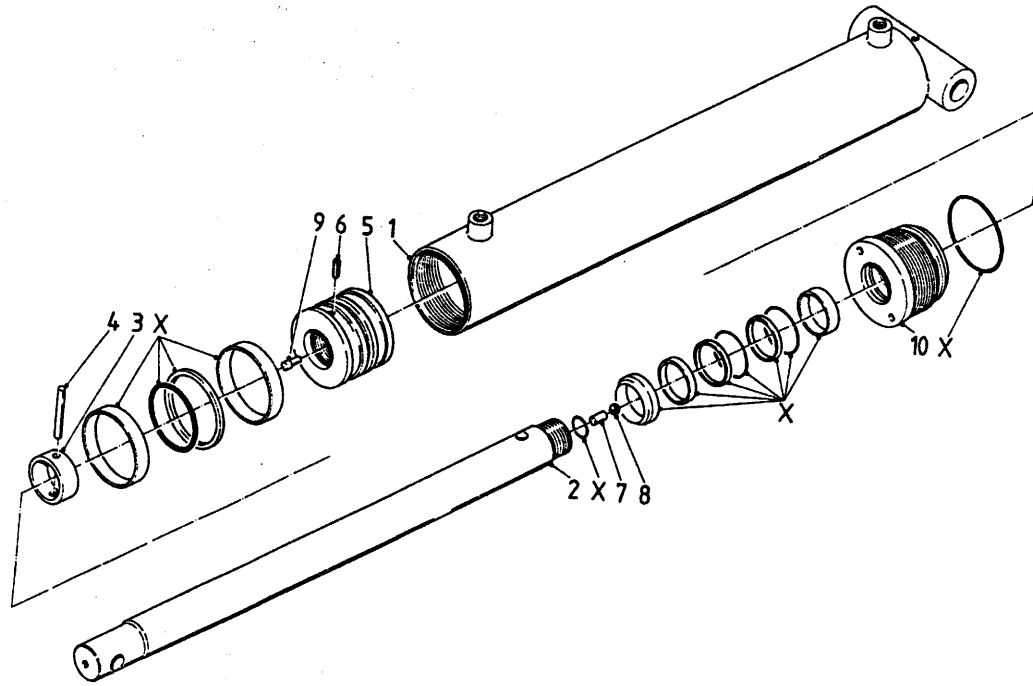

bestelnummer
 ordernummer
 num.à commander
 Bestellnummer

1	11045	1
2	30905	1
3	30906	1
4	88355	1
5	30907	1
6	84146	1
7	88324	1
8	70055	1
9	30909	1
10	30908	1
X	05143	1



Afb. 22

**Aanzet- en intrekcylinder
Schneiddrahmenzylinder**

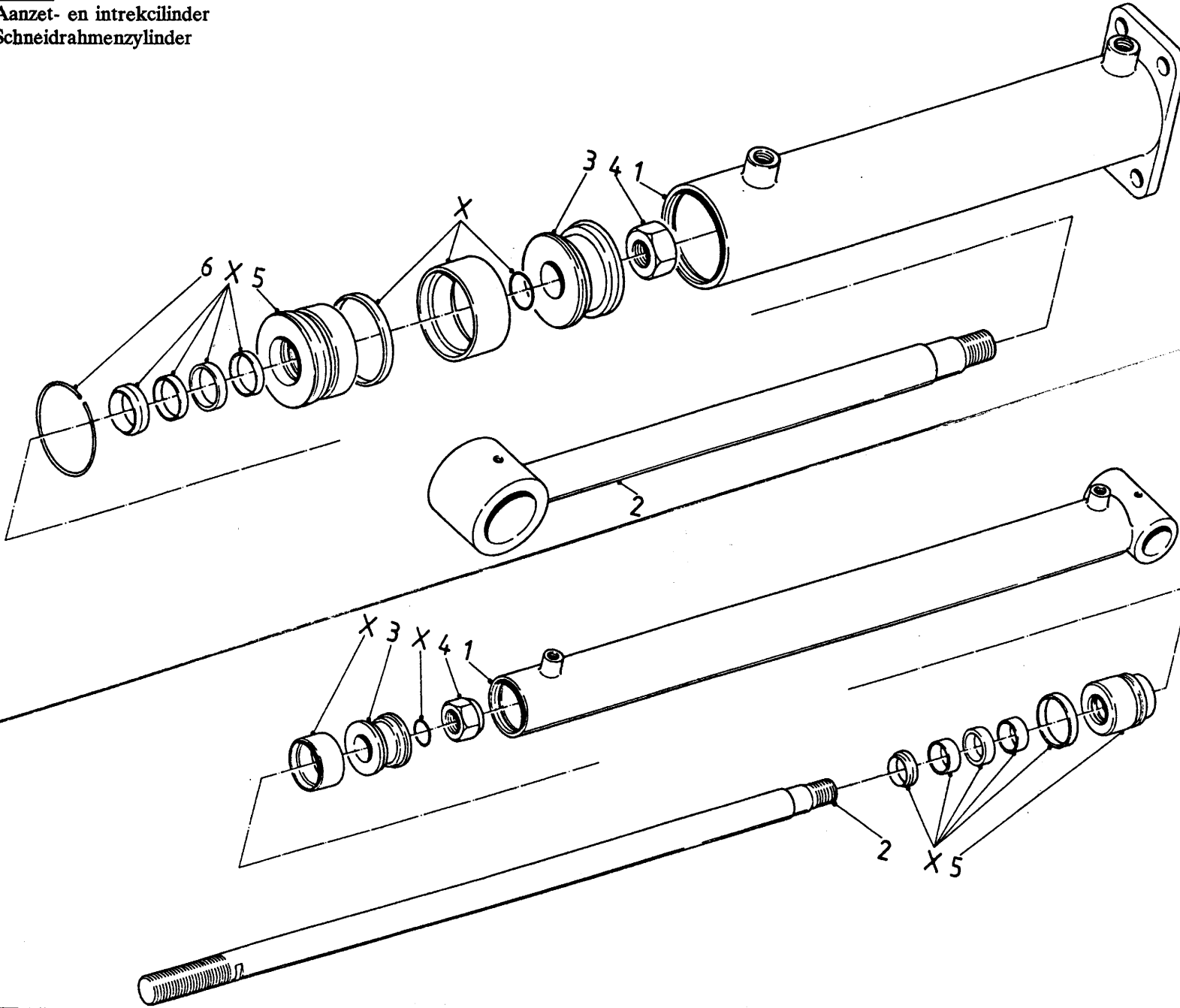

bestelnummer
ordernummer
num.à commander
Bestellnummer



UE 00523

1	11041	1
2	11042	1
3	30902	1
4	86127	1
5	30903	1
6	85802	1
X	05141	1

UE 00217

1	11046	1
2	30910	1
3	30911	1
4	86227	1
5	30912	1
X	05144	1

Afb. 23
Wielarmcilinder
Radarmzylinder

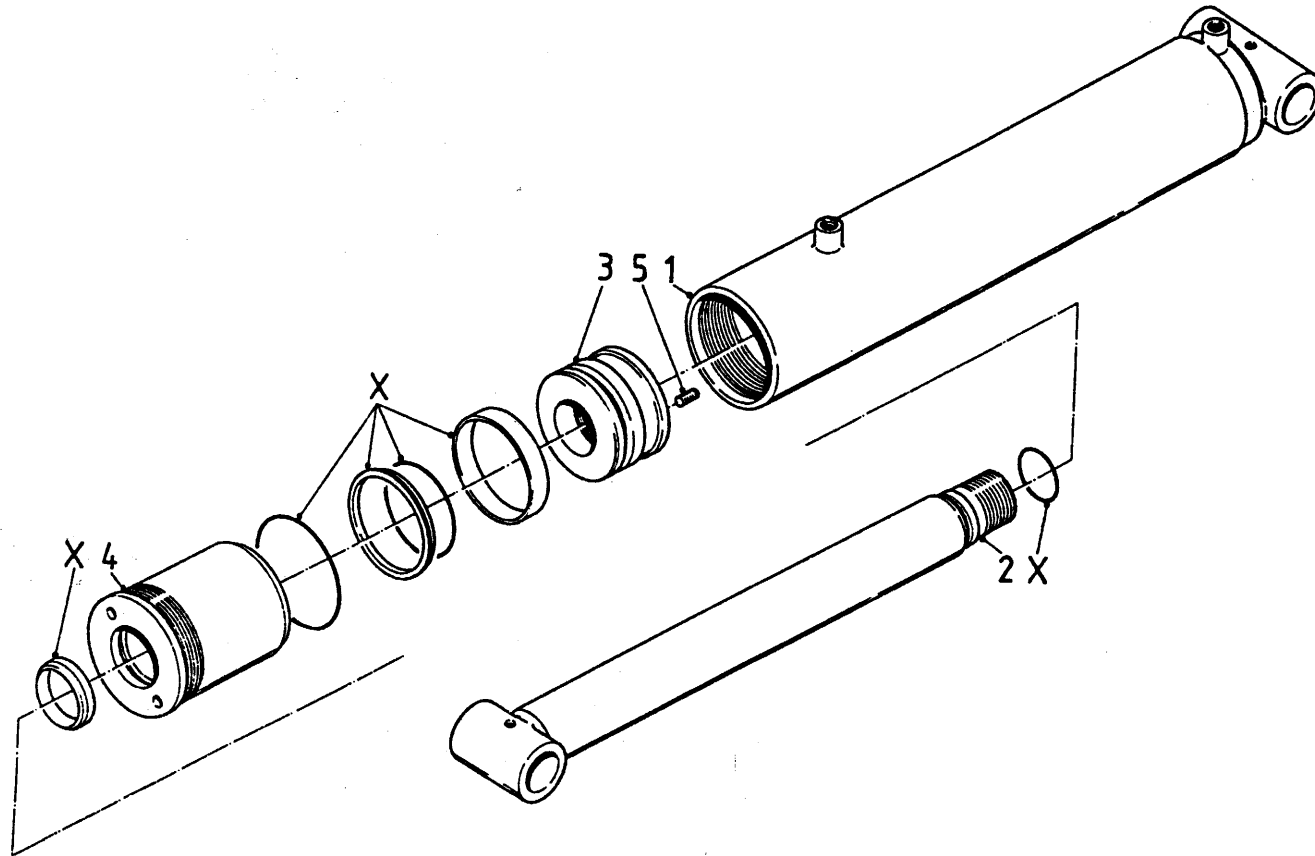

bestelnummer
ordernummer
num.à commander
Bestellnummer



1	11042	1
2	11043	1
3	30900	1
4	30904	1
5	84610	1
X	05142	1

Afb. 24

Elektronisch weegsysteem
Elektronische Waage

bestelnummer
ordernummer
num.à commander
Bestellnummer



Afb. 25
Pompunit
Pumpeinheit

bestelnummer
ordernummer
num.à commander
Bestellnummer



Afb. 26

Schakelschema mechanische bedienung snijstysteem
Schaltplan mechanische Fernbedienung Schneidsystem

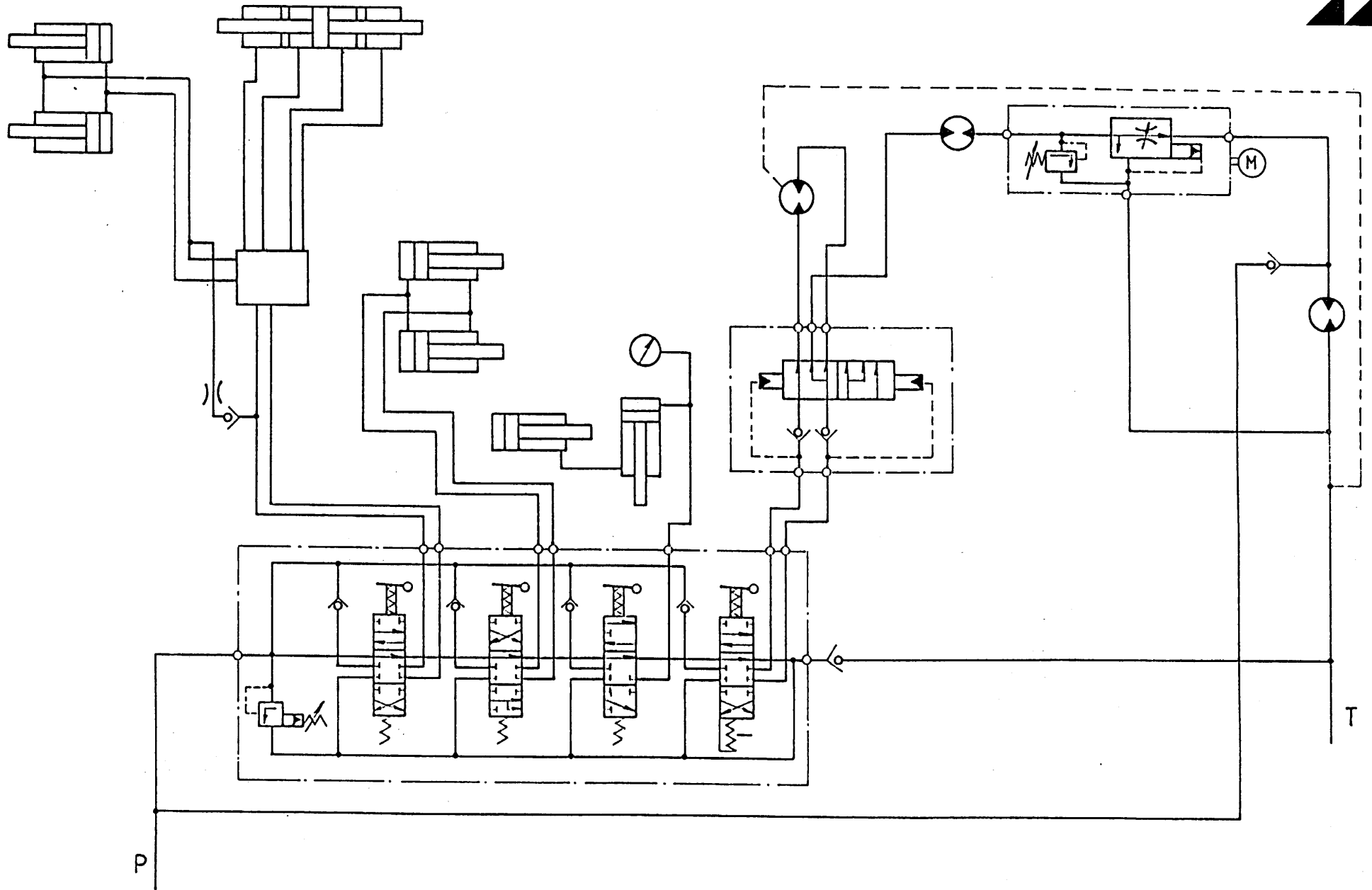

Afb. 27

Schakelschema elektrische bediening snijstelsysteem
Schaltplan elektrische Fernbedienung Schneidsystem

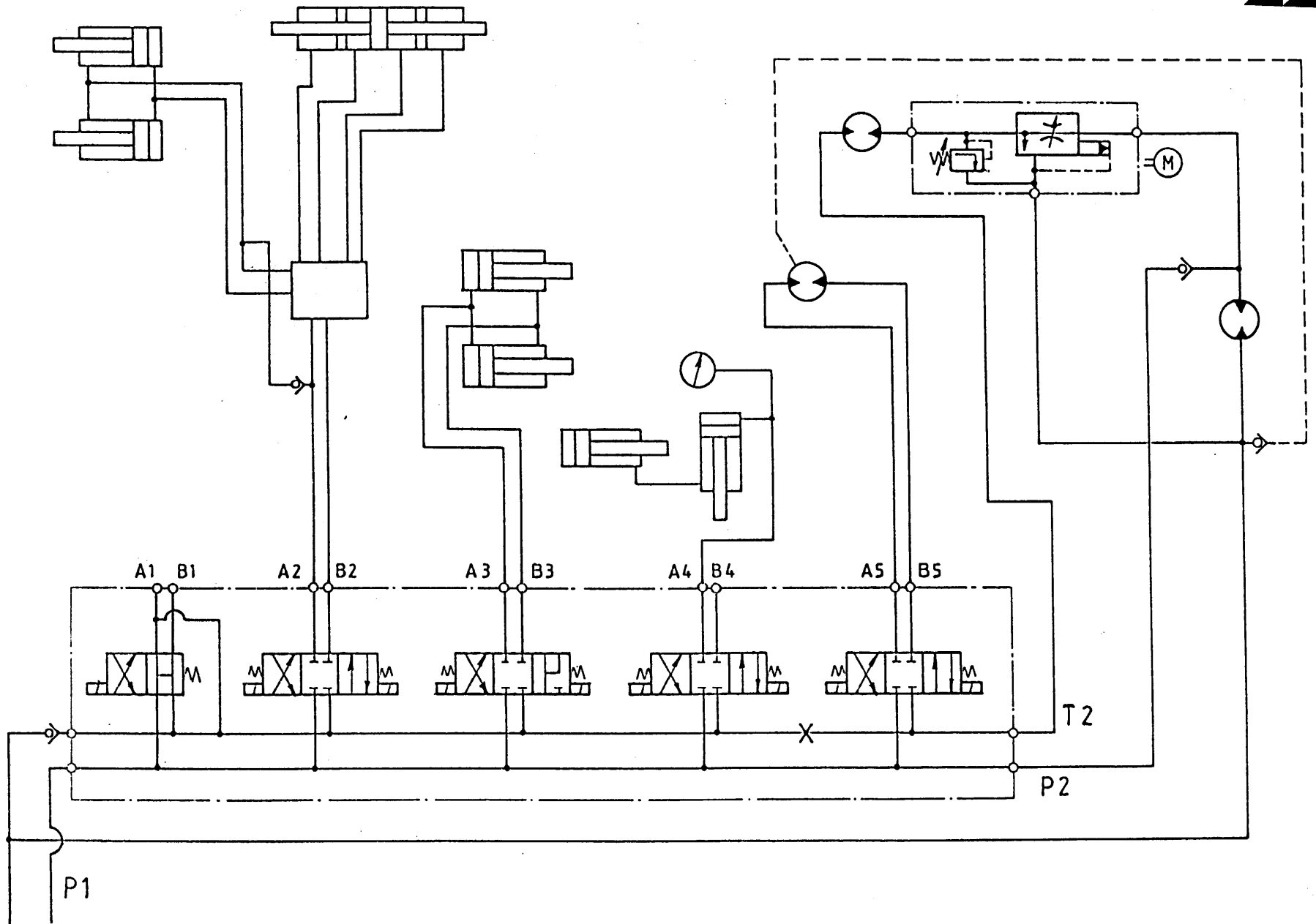

Afb. 28

Schakelschema mechanische bedienung krabbordeem
Schaltplan mechanische Fernbedienung Silokamm

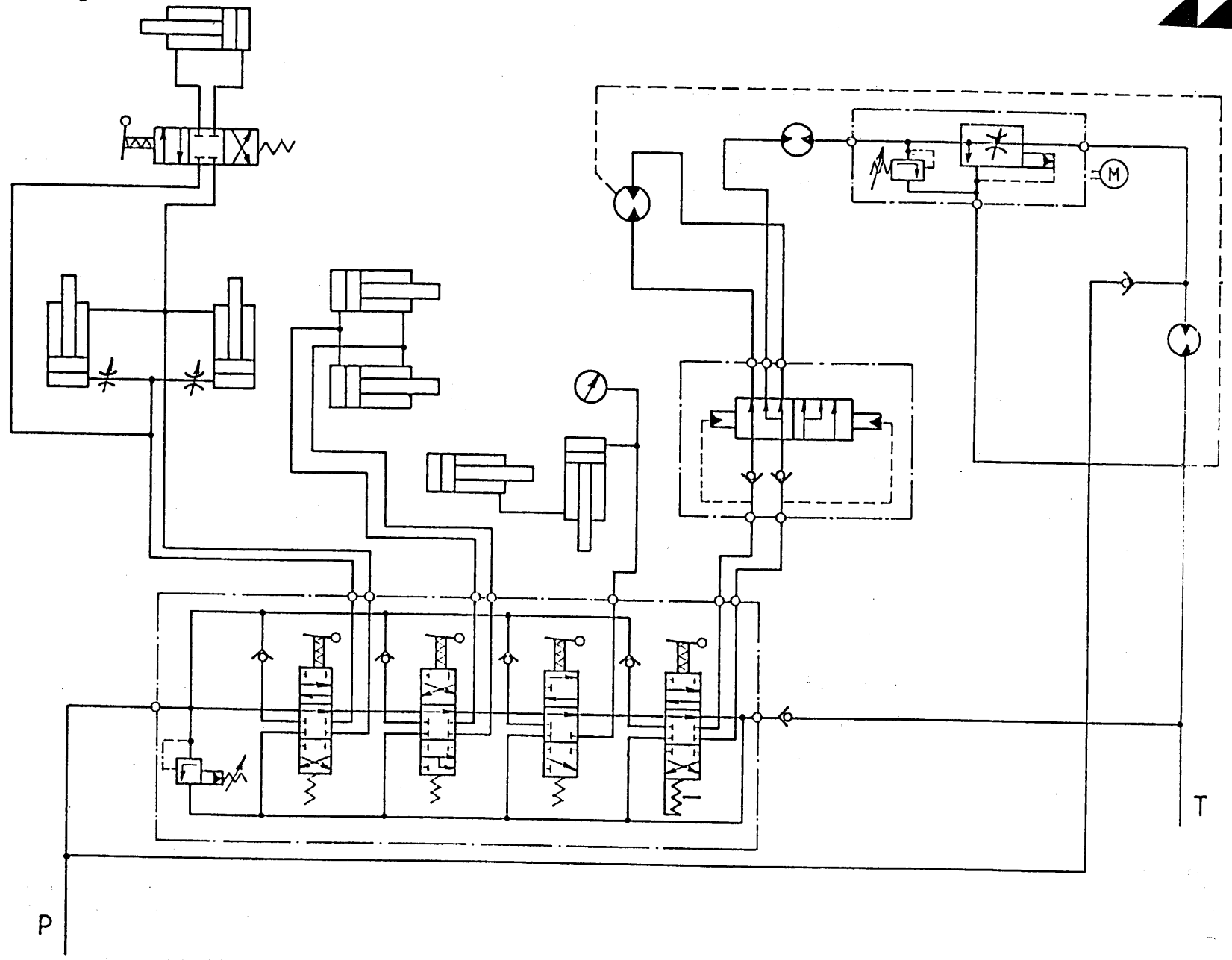

Afb. 29

Schakelschema elektrische bedienung krabbord
Schaltplan elektrische Fernbedienung Silokamm

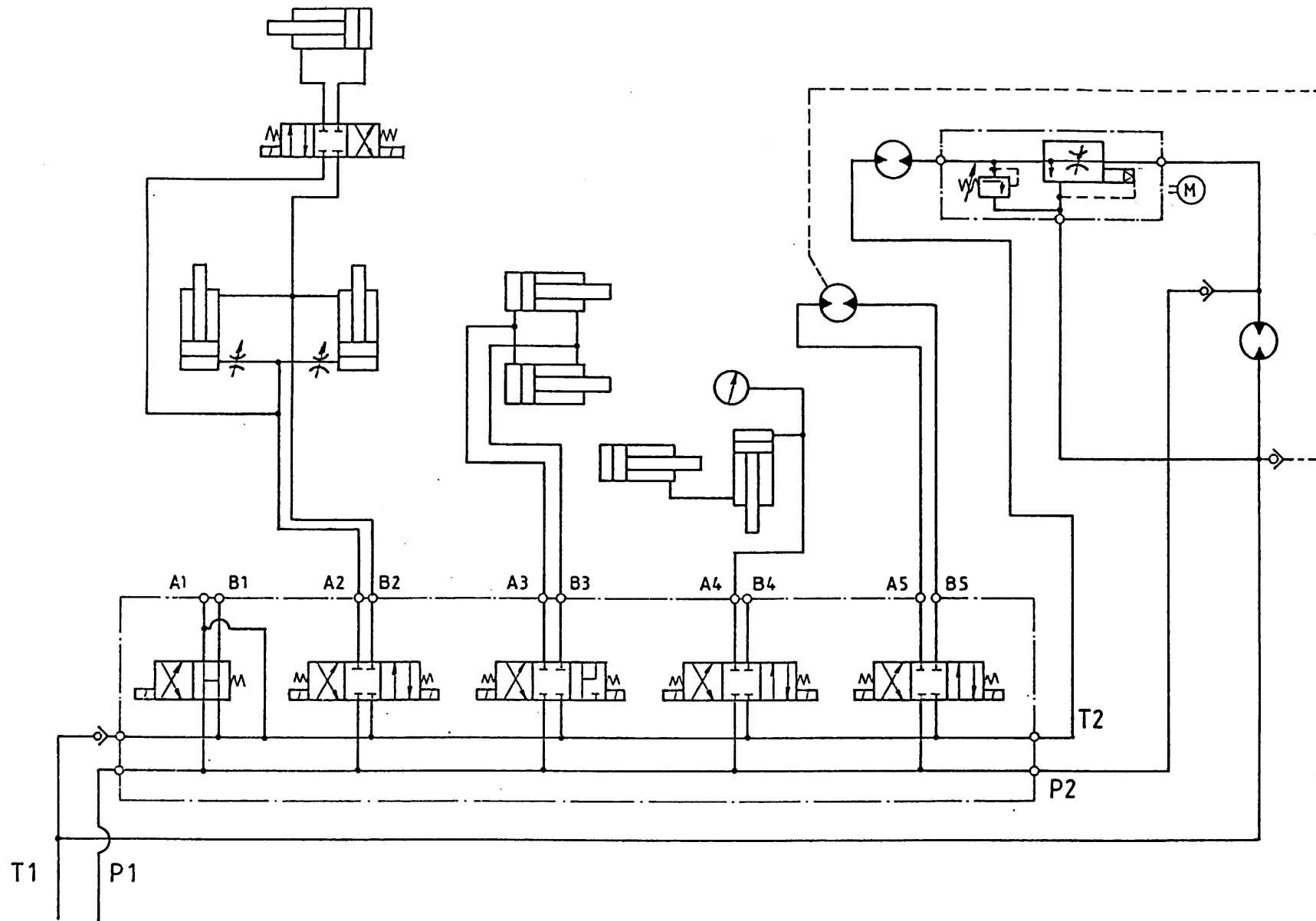

Afb. 30
Schakelschema snijsysteem
Schaltplan Schneidsystem

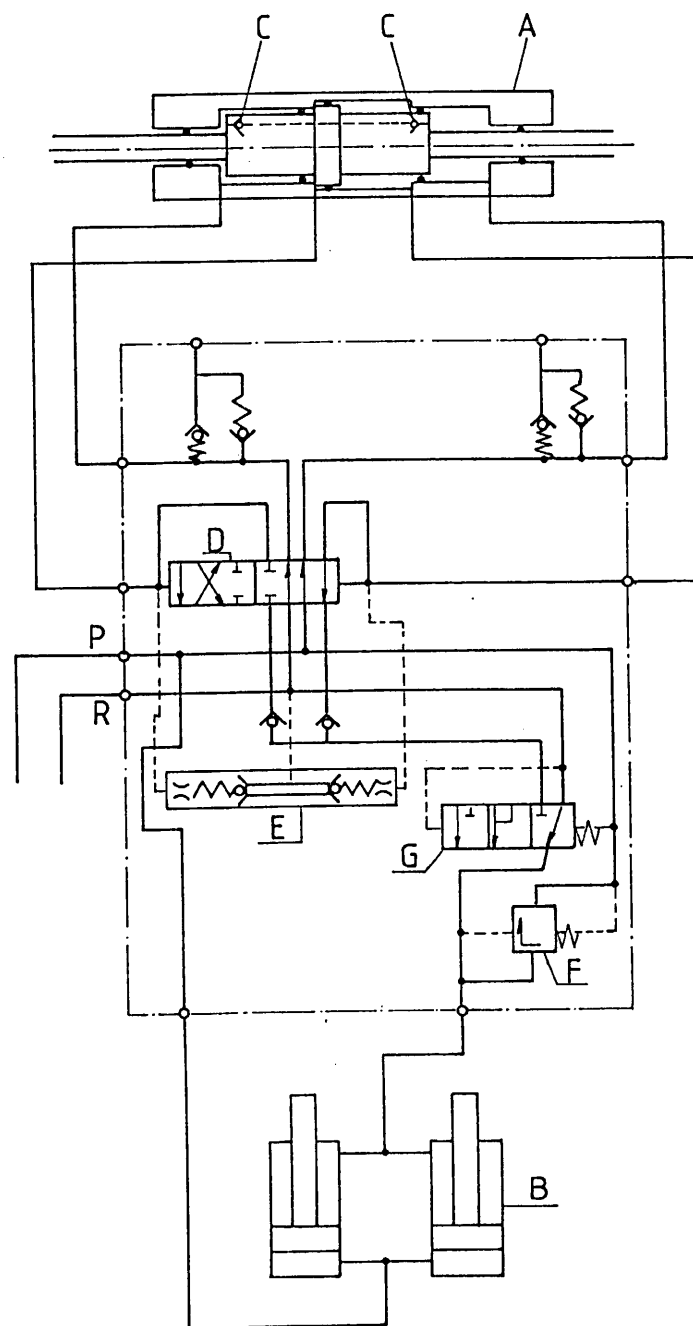



TRIO LIET MULLOS BV
Smitdreeuweg 2, 7581 HE Losser, Holland
Postbus 202, 7580 AE Losser / Postfach 202, 7580 AE Losser, Holland
Telefoon 05423-81700 / Tel. (+) 31 - 5423-81700
Telefax 05423-87605 / Telefax (+) 31 - 5423-87605